



Thank you for choosing a HAVAL vehicle.

The more you know about your vehicle, the more pleasure and convenience you will find when using it. So, you are kindly required: Read this manual carefully before using your vehicle. You will find important information concerning the operation of the vehicle, which will allow you to make full use of its technological advantages. Also, you will get very useful information about driving safety, traffic safety and vehicle maintenance.

Sincerely wish you a safe and happy journey!

Vehicle equipment

Please note that this manual contains all the standard equipment, country-specific equipment and special equipment for this model series. Thus, some equipment or features described in this manual may not be installed onto your vehicle or are only available in some markets. For specific configuration information, please refer to relevant sales materials or consult your vehicle dealer.

Accessories, spare parts and Modifications

Now we can buy not only genuine parts, but also a variety of other spare nongenuine parts and accessories that are suitable for our vehicle. The use of nonauthentic spare parts and accessories may adversely affect vehicle safety, even if these products have been approved by the relevant national or regional authorities. Refer to replacing or installation of non-authentic spare parts and accessories, the Great Wall Motors do not afford any responsibility and do not offer any certificate. It is forbidden to modify vehicles with non-authentic products. Modifications with non-authentic products may affect vehicle operability, safety or durability and may even violate government regulations.

In addition, vehicle damage and performance issues arising from modification are not covered by warranty of quality.

It is forbidden to modify suspension, braking system and so on, which may adversely affect the operate safety of vehicle.

It is forbidden to modify the fuse box of vehicle, unless it may adversely affect the electrical system.

Modification in electronic components, software and circuits will affect their functions and the normal operation of other related components, especially safety-related systems, thus affecting the operation safety of vehicles and increasing the risk of accidents or injuries. Therefore, please do not modify pipeline, electrical parts and software.

Manual timeliness

All information provided in this manual is up to date at the time of publication.

However, due to continuous improvement of the product, the contents of this manual will be updated at any time without notice.

Depending on the vehicle specifications, vehicles shown in the figure may differ from your vehicle.

The display information (including pictures, icons, texts and so on) included in this manual are only for instructions. According to the vehicle model configuration, software version and theme settings, the actual information displayed may be different.

Refer to the actual model for specific information.

About symbols

Warning

This indicates a warning.

Failure to observe these warnings may result in serious injury or death. Such warnings tell you what to do or what not to do so as to reduce the risk of serious injuries or death.

Caution

This indicates a precaution.

Failure to observe these precautions may result in damage to the vehicle or its equipment.

Such cautions tell you what to do or what not to do so as to avoid or reduce the risk of damage to the vehicle and its equipment.

Notice

This indicates a reminder.

Such tips contain helpful information that may be of use to you.

 Page X

This symbol indicates that more details can be seen on this page.

Tips for safety

⚠ Warning

General precautions for your driving:

- › Drive only when fully alert: the alcohol, drug, medicine or anesthetic will slow down driver's response time and affect judgment and coordination, which makes the vehicle get out of control and results in severe safety accidents.
- › Drive carefully: be sure to drive carefully. Always keep an eye on improper movements of other drivers or pedestrians on the road so as to make timely judgments and prevent accidents.
- › Concentrate on driving: be attentive when driving. Anything that distracts the driver's attention, such as adjusting control buttons, call up and answer a mobile phone or reading, may give rise to a crash accident and serious injury to you, passengers on the vehicle and other people.

⚠ Warning

- › When getting out of the vehicle, do not leave children, pets or someone who needs to help in the vehicle alone.
- › Because the children, pets or someone who needs to help cannot get out of the vehicle and save themselves. The temperature in the vehicle may be too high or too low in different weather, which may cause the passengers or pets in the vehicle injury even death.
- › If the children or pets touch the key, the vehicle may move itself which is dangerous for yourselves and the vehicle, including starting the vehicle, releasing the parking brake, shifting gears, operating the doors and windows.

Appearance (Type I)

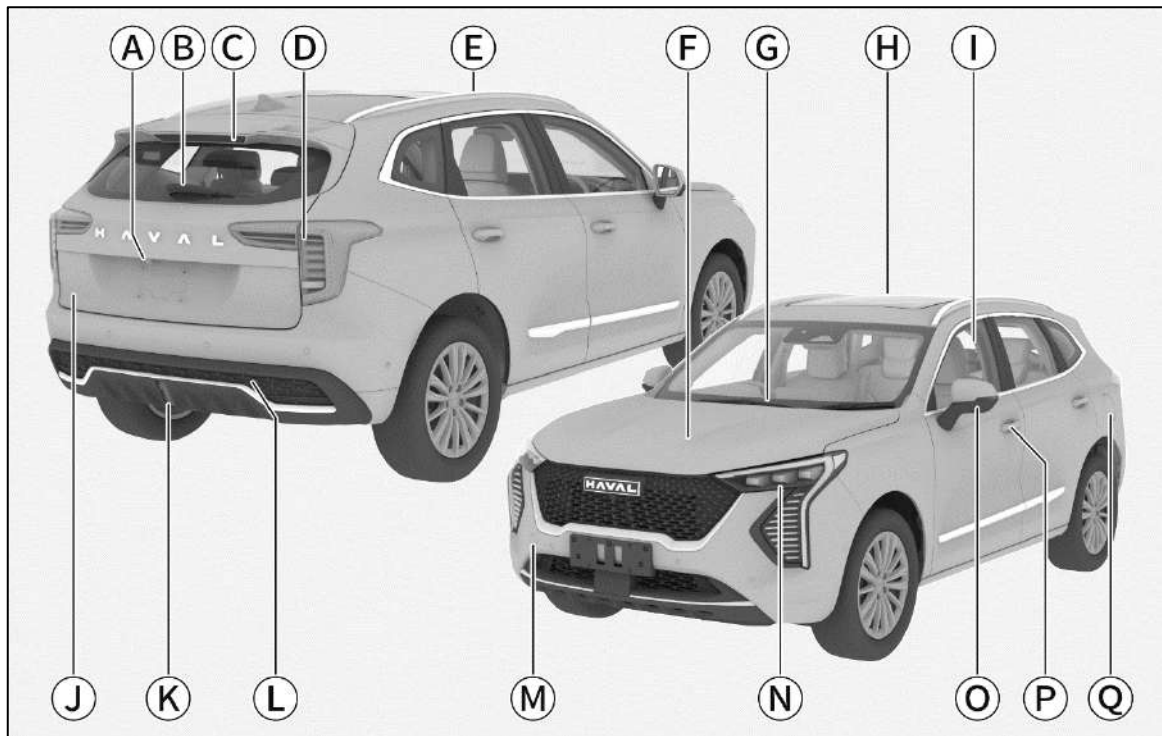

61DCA15C5F3C

Ⓐ The camera, depending on model configuration, may be used for:

Reverse camera **93**

Around view monitor (AVM) **93**

Ⓑ Rear Wiper **46**

Ⓒ High-mounted brake light

Ⓓ Rear combination light

Ⓔ Roof rail **38**

Ⓕ Engine hood **30**

Ⓖ Front wiper **45**

Ⓗ Sunroof **26**

Ⓘ Window **24**

Ⓝ Tailgate **21**

Ⓚ Rear Fog light **41**

Ⓛ Rear tow hook cover **186**

Ⓜ Front tow hook cover **186**

Ⓝ Front combination lamp

Ⓞ Side mirror **35**

Ⓟ Door handle **19**

Ⓠ Fuel door **29**

Appearance (Type II)

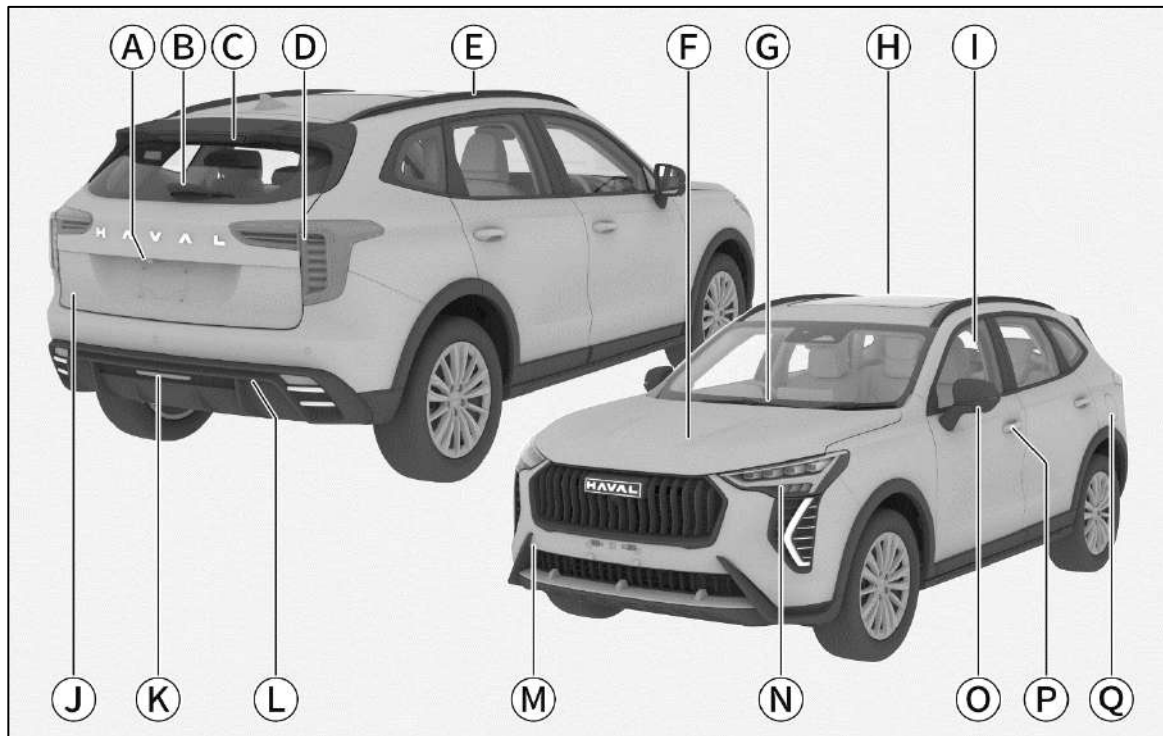

AD2EE5CCE45C

- | | |
|--|--|
| <p>Ⓐ The camera, depending on model configuration, may be used for:
Reverse camera 93
Around view monitor (AVM) 93</p> | <p>Ⓘ Window 24</p> |
| <p>Ⓑ Rear Wiper 46</p> | <p>⓵ Tailgate 21</p> |
| <p>Ⓒ High-mounted brake light</p> | <p>Ⓚ Rear Fog light 41</p> |
| <p>Ⓓ Rear combination light</p> | <p>Ⓛ Rear tow hook cover 186</p> |
| <p>Ⓔ Roof rail 38</p> | <p>Ⓜ Front tow hook cover 186</p> |
| <p>Ⓕ Engine hood 30</p> | <p>Ⓝ Front combination lamp</p> |
| <p>Ⓖ Front wiper 45</p> | <p>Ⓞ Side mirror 35</p> |
| <p>Ⓗ Sunroof 26</p> | <p>Ⓟ Door handle 19</p> |
| | <p>Ⓠ Fuel door 29</p> |

Interior trim

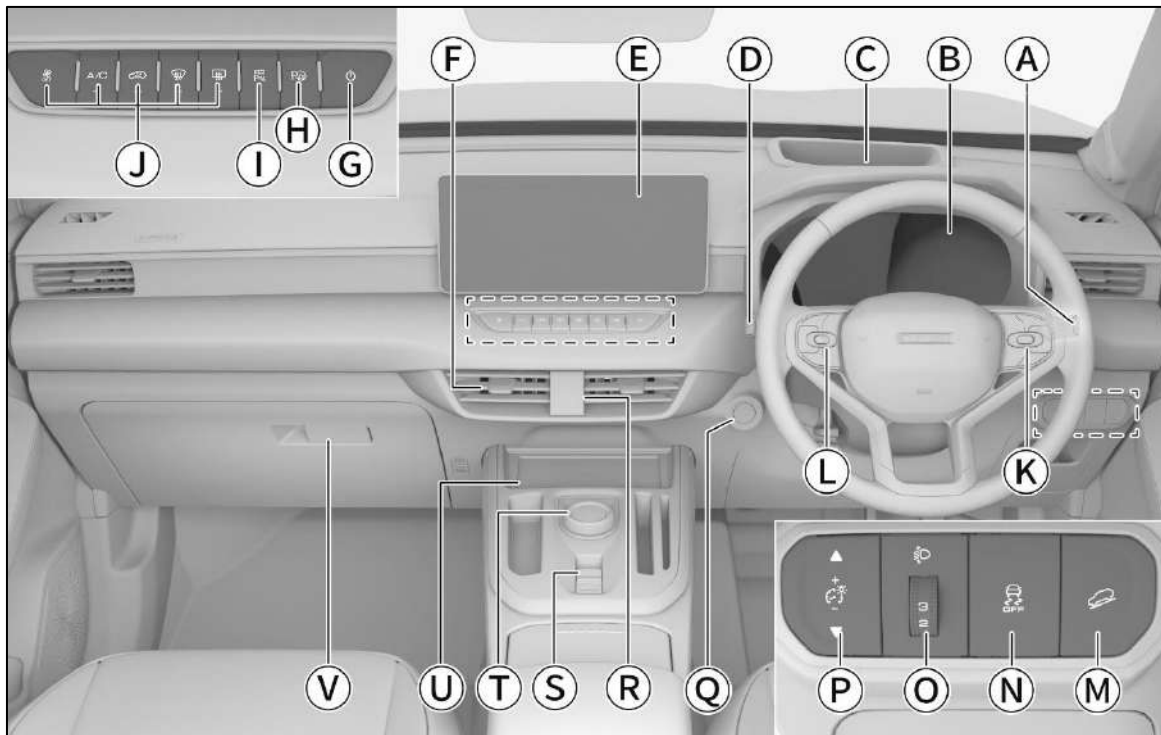

9BF688B011B3

- Ⓐ Due to different model configurations, it may be used for:
Wiper control combination switch (electric) 45
Wiper control combination switch (auto) 45
- Ⓑ Virtual instrument 123
Indicator lights on the instrument 128
- Ⓒ Head up display 122
- Ⓓ Light control combination switch 41
- Ⓔ Multimedia display 142
- Ⓕ A/C outlets 50
- Ⓖ Audiovisual system power supply button 139
- Ⓗ Auto parking assist system button 96
- Ⓘ Around view monitor button 93
- Ⓝ Air conditioning button 50
- Ⓚ Steering wheel right button can be use for:
Cruise control system 100
Cruise control assist system 102
Virtual instrument adjustment 125
- Ⓛ Audiovisual system control button
- Ⓜ Hill descent control system button 117
- Ⓝ Electronic stability control button 119
- Ⓞ Light height adjustment knob 43
- Ⓟ Instrument brightness adjustment button 43
- Ⓠ Power supply switch 76
- Ⓡ Hazard warning light button 42
- Ⓢ Parking brake switch (EPB) 79
- Ⓣ Shift knob 81
- Ⓤ Mobile phone wireless charging 57
- Ⓥ Storage box 59

Table of contents

1	Operation	This chapter introduces the method for operating on-board vehicle equipment, such as keys, doors, windows and seats.	
2	Driving	This chapter introduces the driving information, such as vehicle start, gear shifting and instrument of the vehicle.	
3	Audiovisual system	This Chapter introduces the Bluetooth telephone, system setting and other audio-visual system related information.	
4	Safety	This Chapter introduces the functional equipment, such as antitheft system and seat belts.	
5	Emergency	This Chapter introduces the treatment methods for vehicle failures such as flat tyre and battery loss.	
6	Maintenance	This Chapter introduces the routine inspection and regular maintenance of the vehicle.	
7	Technical data	This Chapter introduces the vehicle parameters, identification number and other information.	
8	Index	This Chapter introduces the alphabetical index in this manual.	

Operation	
Key	16
About the key	16
Button introduction	16
Battery replacement	17
Door lock	19
Locking and unlocking through the PEPS	19
Locking and unlocking with key buttons	19
Locking and unlocking with center control buttons	19
Unlock with the interior handle	19
Locking and unlocking with the mechanical key	20
Locking during emergencies	20
Tailgate	21
Child safety lock	22
Unlocking after flameout	20
Auto driving lock	23
Automatic resetting	23
Automatic unlock upon collision	23
Anti-misoperation lock	23
Window	24
Window switch	24
Thermal protection function	25
Anti-pinch function	25
Delay function	25
Speed closing	25
Initialization	25
Sunroof	26
Opening and closing the sunroof	26
Opening and closing of sunshade	26
Thermal protection function	27
Linkage function	27
Anti-pinch function	27
Delay function	27
One-click closing	27
Automatic sunroof closing	27
Initialization	28
Refuelling	29
Refueling method	29
Fuel information	29
Engine hood	30
Opening	30
Close	30
Seat	31
Headrest	31
Front seat	32
Rear seat	33
Rearview mirrors	35
Interior rearview mirror	35
Outside rearview mirror	35
Steering wheel	37
How to adjust	37
Horn	37
Roof rails	38
Roof rack	38
Light control	39
Light setting	39
Light control combination switch	41
Follow me home function	42
Daytime running lamp	42
Emergency braking warning	42
Emergency hazard flashers	42
Light height adjustment	43
Instrument brightness adjustment	43
Interior lights	43

Wiper controls	45	Advice on driving in harsh environments	68
Electric wiper.....	45	Driving in foggy weather.....	68
Automatic wiper.....	45	Driving in the rain.....	68
Front wiper and washer setting.....	45	Wading drive.....	68
Air conditioning system	50	Driving during the hot seasons.....	69
Air conditioning control panel.....	50	Driving in cold season.....	69
A/C setting interface.....	52	Advice on driving during run-in period 72	
A/C setting.....	54	Tyre.....	72
Air conditioning control.....	55	Friction lining of brake pad.....	72
A/C vent.....	56	Hybrid vehicles	73
Mobile phone wireless charging	57	About hybrid vehicle.....	74
Instructions.....	57	Energy recovery.....	74
Interior equipment	59	Power battery vent.....	75
Sun visor.....	59	Battery safety switch.....	75
Vanity mirror.....	59	Power supply mode	76
Storage box.....	59	Power supply mode switching.....	76
Storage case.....	60	Starting and shutting down vehicle	77
Spectacle case.....	60	Starting the vehicle.....	77
Front cup holder.....	60	Shutting down the vehicle.....	77
Rear cup holders.....	60	Parking brake	79
Bottle holder.....	61	Tips for safety.....	79
Power supply socket.....	61	Electronic parking brake.....	79
Driving		Automatic transmission	81
Driving procedures	64	Introduction to gear position.....	81
Before driving.....	64	How to shift.....	81
Precautions for driving.....	64	Crawling function.....	82
Precautions for passengers.....	64	Start the vehicle.....	82
Parking the vehicle.....	67	Stop the vehicle.....	83
Economic driving.....	67	Driving mode	84
		Switching method.....	84

Single pedal function	85	Intelligent driving assist system	107
Single pedal function.....	85	Intelligent driving.....	107
Vehicle wash/trailer mode	87	Forward assist system.....	108
Vehicle wash/trailer mode.....	87	Lane keeping assist system.....	110
Fording mode	88	Rear side assist system.....	112
Wading mode.....	88	Traffic sign information.....	115
Steering wheel assist mode	89	Hill descent control system	117
Switching method.....	89	Hill descent control system introduction	
Parking assist system	91	117
Safety tips.....	91	Instructions.....	117
Reverse radar.....	92	Driving assist system	118
Anti-collision radar.....	92	Tips for safety.....	118
Reverse camera.....	93	Anti-lock brake system.....	118
Around View Monitor (AVM).....	93	Electronic braking force distribution	
Auto parking assist system.....	94	system.....	118
Parking settings.....	96	Braking force assist system.....	118
Tyre pressure monitoring system	98	Traction control system.....	118
System introduction.....	98	Rollover prevention system.....	119
Monitoring function.....	98	Secondary collision mitigation system	
Alarm function.....	98	119
Fatigue driving reminder system	99	HHC (Hill-start Hold Control).....	119
Introduction of fatigue driving reminder		Electronic power steering system.....	119
.....	99	Electronic stabilization program.....	119
Instructions.....	99	Emission control system	120
Functional limitations.....	99	Tips for safety.....	120
Cruise control system	100	Oxygen sensor.....	120
Cruise control system introduction.....	100	Catalytic converter.....	120
Instructions.....	100	Fuel evaporation control unit.....	120
Cruise control assist system	102	Crankcase emission control unit.....	120
System description.....	102	On-board diagnostic system.....	121
Instructions.....	102	Head-up display (HUD)	122
Queuing auxiliary function.....	105	About the system.....	122
Curve road auxiliary function.....	105	How to use.....	122
Lane center keeping function during			
cruising.....	105		
Functional limitations of the cruise assist			
.....	106		
Sensor.....	106		

Virtual instrument	123
Summary.....	123
Steering wheel button.....	125
Driving data interface.....	125
Audio media interface.....	126
Bluetooth interface.....	126
Navigation information interface.....	126
Alarm information interface.....	126
Menu setting interface.....	127
Indicator lights on the instrument	128
Indicator lights on the instrument.....	128
Power supply management system	134
System introduction.....	134
Information you should know.....	134

Audiovisual system

Safety prompt	138
Safety.....	138
About the use.....	138
About the radio.....	138
About USB storage devices.....	138
About Bluetooth.....	138
Panel	139
Steering wheel buttons.....	139
Power supply switch.....	139
External devices.....	139
Display screen	141
Display screen operation.....	141
Display screen status bar.....	141
Interface introduction	142
Menu interface.....	142
Shortcut panel.....	145
Interconnection.....	146
System Setting.....	147
Voice assistant.....	152
Navigation system.....	155

Safety

Seat belts	161
Wear the seat belt properly.....	162
Pretensioner seat belt.....	162
How to use the three-point seat belt.....	163
Airbags	164
Tips for safety.....	164
Airbag.....	165
Front airbags.....	166
Front passenger airbag switch.....	167
Side airbags.....	168
Curtain airbags.....	168
Child restraint system	170
Safety instructions for child seat.....	170
Fixing point for child seat.....	171
Recommended child seat categories.....	171
Installation of child seat.....	171
Vehicle anti-theft system	174
System introduction.....	174
System activation.....	174
Alarm trigger condition.....	174
Alarm cancellation.....	174
System off.....	174
Emergency cut-off system	175
Emergency cut-off system.....	175
Event data recorder	176
System introduction.....	176
Data reading.....	176
Data disclosure.....	176

Emergency

On-board toolkit	179
Location of on-board toolkit.....	179
Emergency tyre repair and inflation	180
Inflator and tyre repair fluid.....	180
Emergency tyre repair.....	180
Tyre inflation.....	181
In case of an accident	182
Traffic accidents occur to vehicles....	182
Jump start	183
Symptoms of a drained vehicle battery	
.....	183
How to jump start the vehicle.....	183
Engine overheating	185
When the engine is overheated.....	185
Towing	186
Use a professional vehicle to tow.....	186
Towing with the tow hook.....	187
Service and rescue	190
On-board telephone.....	190
Call center.....	190
Emergency rescue.....	190
Car networking function indicator....	191

Maintenance

Necessity of vehicle maintenance	193
Engine compartment	194
Tips for safety.....	194
Fluid level.....	195
Engine oil.....	196
Brake fluid.....	197
Engine/drive motor coolant.....	197
Windscreen washer fluid.....	197
Radiator and fan.....	198
Safety labels and identifiers.....	198
Parts replacement	200
Fuses.....	200
Wiper blade.....	201
Bulbs.....	203
Vehicle maintenance	204
Tyre maintenance.....	204
Sunroof maintenance.....	204
Battery.....	206
Exterior maintenance.....	206
Interior maintenance.....	207
Anti-corrosion measures.....	208
Long-term storage of the vehicle....	209
Regular maintenance table	210

Technical data

Vehicle identification.....	213
Vehicle identification number.....	213
Engine number.....	213
Overall Parameter	214
Basic specification.....	214
Power specification.....	214
Tire specification.....	215
Wheel specification.....	215
Braking specification.....	215
Fluid specification.....	216
Seat specification.....	217

Index

Alphabetical index.....	220
-------------------------	-----

Key.....	16
Door lock.....	19
Windows.....	24
Sunroof.....	26
Refuelling.....	29
Engine hood.....	30
Seat.....	31
Rearview mirror.....	35
Steering wheel.....	37
Roof rails.....	38
Light controls.....	39
Wiper controls.....	45
Air conditioning system.....	50
Wireless charging.....	57
Interior equipment.....	59

Vehicle equipment

Please note that this manual contains all the standard equipment, country-specific equipment and special equipment for this model series. Thus, some equipment or features described in this manual may not be installed onto your vehicle or are only available in some markets. For further configuration information, please refer to relevant sales information or consult with your distributor selling the vehicle to you.

About the key

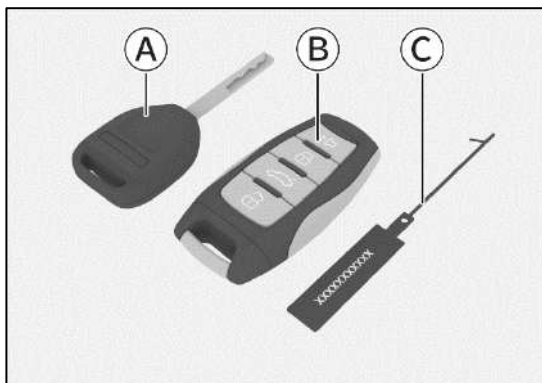

DFCE00A8EDDF

- (A) Mechanical key
- (B) Smart Key
- (C) Key number tag

i Notice

This communication device conforms to standards or technical requirements of NBTC.

i Notice

- › Store the key number tag in a safe place. The key number tag has a code necessary for getting a new key. You may only request a new mechanical key from the authorised service centre by using this code.
- › When purchasing or transferring the vehicle, hand over the key number tag to the purchaser.

Button introduction

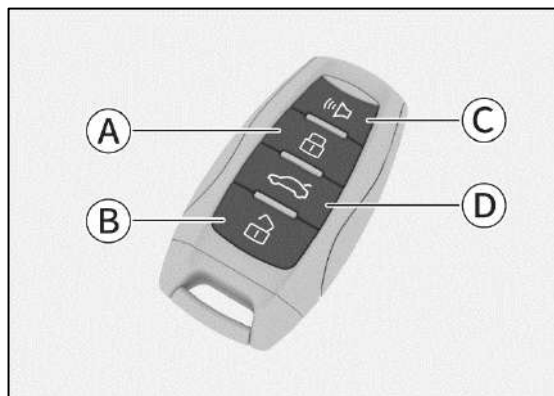

964859EEC481

- (A) Lock button
- (B) Unlock button
- (C) Vehicle locating button
- (D) Back door control button

Lock button

Press the lock button to lock all the doors and back door. In this case, the turn signal lamp will flash once.

i Notice

When the door is locked, if the turn signal lamps do not flash, check whether all the doors and back door and the engine hood are closed fully.

Unlock button

Press the unlock button to unlock all the doors and back door. In this case, the turn signal lamp will flash twice.

i Notice

The door unlock mode can be set on multimedia via [Vehicle setting] → [In-car] → [Body]

If the unlock mode is set to [driver] when the unlock button is pressed, only the driver's door and back door will be unlocked. At this time, if the unlock button is pressed again, all vehicle doors will be unlocked.

If the unlock mode is set to [Four Doors], press unlock button to unlock all the doors and back door.

Vehicle locating button

When all doors and back door are locked, press this button to turn on the locating function so that you can quickly find your vehicle in a parking lot.

Press it again during vehicle locating alarm to cancel the locating function.

i Notice

The door unlock mode can be set on multimedia via [Vehicle Settings] →[【In-Car】 →[Light]

Back door control button

Press and hold the back door control button to unlock the back door and press the back door micro switch to open the back door within 30 seconds after unlock.

⚠ Caution

- › Modifying the transmission frequency of the intelligent key, boosting the key's transmission power (including by installing a frequency-power amplifier), connecting it to an external antenna, or using other transmitting antennas is forbidden.
- › It is strictly forbidden to use the key to interfere with various legal wireless communication services. Once such interference has been discovered, the use of the key should be halted and measures should be taken to prevent such interference before resuming use
- › The use of the key may be affected by the interference of various wireless equipment, resulting in short-term failure of its function.

Battery replacement

⚠ Warning

The vehicle key contains a battery.

- › The battery in the vehicle key is dangerous. Regardless it is a new battery or an old one, you should always keep away from children.
- › If swallowed or put into any part of the body, the battery may cause serious or fatal injury in 2 hours or less.
- › Seek medical attention if you suspect the battery has been swallowed or placed in any part of the body.
- › Please dispose of used batteries according to local laws. Incorrect disposal of used batteries will damage the environment.

⚠ Caution

- › Both hands must be dry during the process. Moisture may cause rusting of the battery.
- › Do not touch or move any other parts.
- › The positive and negative terminals of the battery must be installed correctly.
- › Be careful not to lose parts when replacing the battery.

1. Push the release button of smart key to eject the mechanical key.

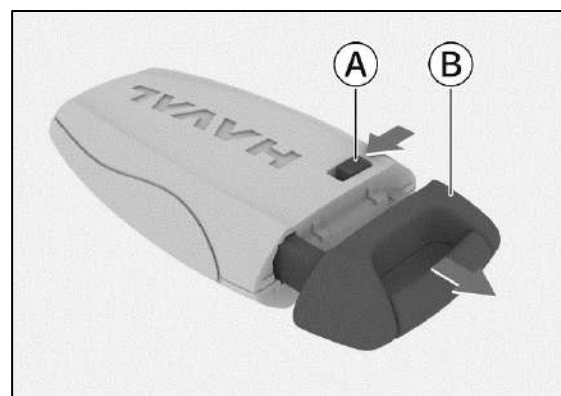

E1536A109E1D

- (A) Release button
- (B) Mechanical key

2. Pry open the cover of the key using a flathead screwdriver, and remove the cover.

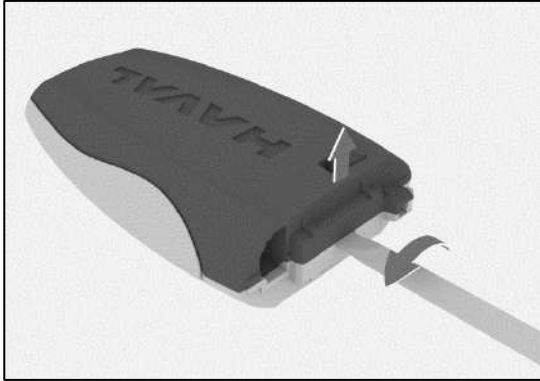

257B83A9D7D8

3. Take out the battery and insert a new battery in its place.

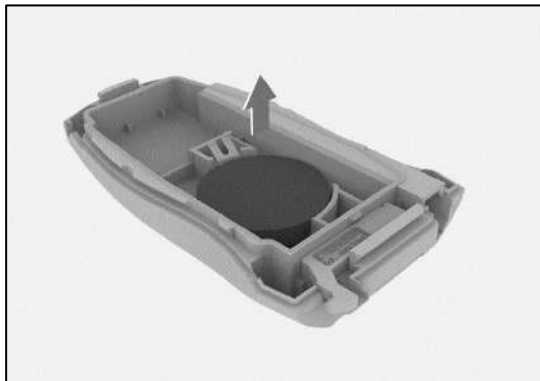

BOB391378D50

When installing the battery, make sure that the positive terminal of the battery is facing down.

Battery model: CR2032

4. Install the rear key cover. After installation, make sure that all the key buttons are working properly.

Door lock

Vehicle equipment

Please note that this manual contains all the standard equipment, country-specific equipment and special equipment for this model series. Thus, some equipment or features described in this manual may not be installed onto your vehicle or are only available in some markets. For further configuration information, please refer to relevant sales information or consult with your distributor selling the vehicle to you.

Locking and unlocking through the PEPS

When you carry the smart key with you, you can use the passive entry and passive start system (PEPS) to lock and unlock the vehicle door.

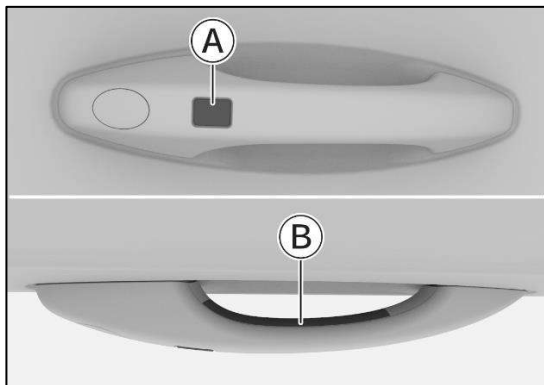

A57BF698199F

- (A) Lock sensor
- (B) Unlock sensor

Unlocking

Touch the unlock sensor to unlock all the doors and the tailgate. In this case, the turn signal lamp will flash twice.

i Notice

The door unlock mode can be set via [Vehicle Settings]→[In-Car]→[Body] on the multimedia display screen. If the unlock mode is set to [Driver] when the unlock button is pressed, only the driver door and tailgate will be unlocked. At this time, if the unlock button is pressed again, all vehicle doors will be unlocked. If the unlock mode is set to [Four Doors], press unlock button to unlock all the doors and tailgate.

Locking

Touch the lock sensor to lock all the doors and the tailgate. In this case, the turn signal lamp will flash once.

i Notice

When the door is locked, if the turn signal lamps do not flash, check whether all the doors, the tailgate and the engine hood are closed fully.

i Notice

- > Only the doors with smart key detected can be operated.
- > Do not lock and unlock the door at the same time.
- > If you wear gloves to operate the door handle, you may not be able to unlock or lock the door.
- > The radio waves of the PEPS is a little weak. When they are surrounded by other radio equipment or blocked by other barriers, the communication between the smart key and the vehicle may be affected and the system will not work normally.
- > Every time the door is successfully locked or unlocked, the PEPS system will stop working for 3 s.

Locking and unlocking with key buttons

See the key button for introduction (▷ Page 16)

Locking and unlocking with center control buttons

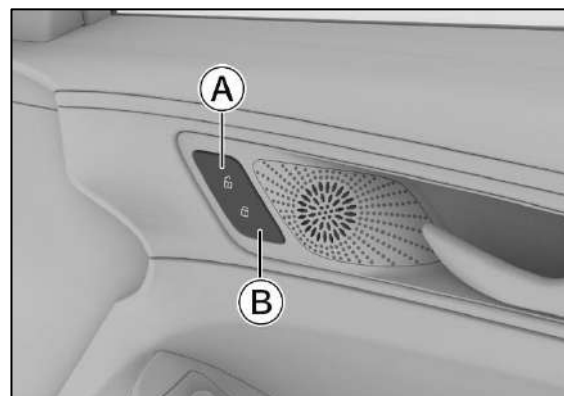

8F40E1A4B746

- (A) Unlock button
- (B) Lock button

The center control button is located on the driver's door. Press the central control buttons to lock or unlock all doors.

Unlocking with the interior handle

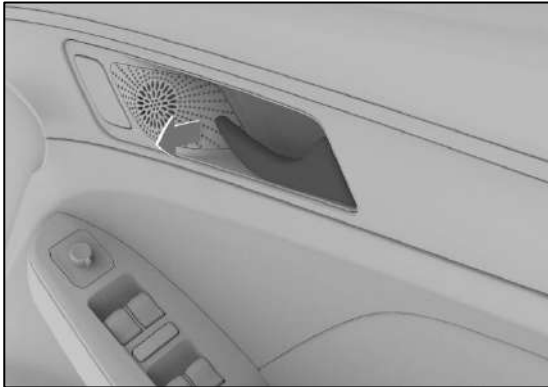

468DCB02AC78

When a vehicle door is locked, pulling the interior handle will unlock it. Pull the handle again to open the door.

i Notice

Make sure that the child lock is not active when opening the rear doors with the inner handle; otherwise, the rear doors cannot be opened.

Locking and unlocking with the mechanical key

1. Pull up the door handle and push the cover from the inside to remove it.



EDB126DE58F3

2. Insert the mechanical key into the door lock hole, and turn the key to lock or unlock the door. For how to get the mechanical key, refer to Replacement of Key Battery.

(▷หน้า 20)



361E36239106

⚠ Caution

After unlocking the vehicle door, you must first pull out the mechanical key in order to open the driver door.

i Notice

When the mechanical key is used to unlock the door, the vehicle anti-theft alarm may be triggered.

Locking during emergencies



4D20BEE53777

The front passenger's door and the rear door are equipped with the door emergency locking device.

Insert the mechanical key into the emergency lock hole as shown in the figure, move it to the lowest position, and then close the door to lock it.

i Notice

If you need to use this method to lock the door, it means that the electric door lock system has malfunctioned. In this case, please go to the authorised service centre for maintenance as soon as possible.

Tailgate

Manual tailgate

Opening

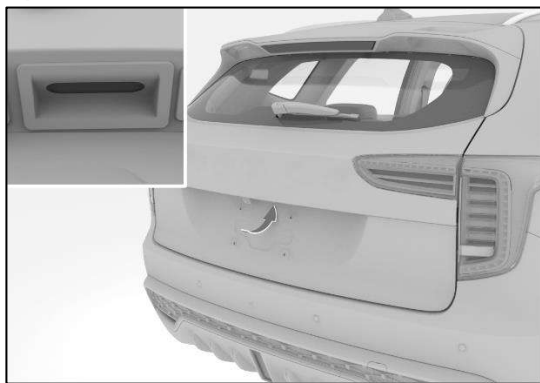

B2D827F79BAF

- › When you carry the smart key with you, press and pull up the tailgate microswitch.
- › When the power supply switch is in the OFF position, press and hold the tailgate control button on the key, and press and pull up the tailgate microswitch within 30 seconds.
- › When the driver door is unlocked, press and pull up the tailgate microswitch.

Closing



3C9858EA539B

1. Pull the tailgate handle downwards and release the handle before the tailgate is fully closed.

2. Press the tailgate from outside the vehicle to make sure that it is fully closed.

⚠ Warning

- › When closing the tailgate manually, be sure to press the tailgate outside the vehicle to make it completely closed.
- › Using the handle to close the tailgate can pinch your hand and result in serious injury.
- › Do not drive the vehicle when the tailgate is open.
- › No passengers are allowed in the luggage area.
- › Be careful not to injury anyone near the tailgate when opening or closing.
- › When closing the tailgate, be careful not to pinch any object, such as a bag or necktie.
- › Do not allow children to operate the tailgate. Otherwise, an accidental injury may be caused.

⚠ Caution

- › Do not use excessive force when opening the tailgate; otherwise, it will easily damage the tailgate.
- › Always be careful when opening the tailgate in strong wind. The strong wind can cause the tailgate to open too far and deform.
- › If the tailgate is frozen or covered in snow and ice, do not force it open.
- › First use the heating function to warm the interior of the vehicle, and then open the tailgate.
- › If you must open the tailgate in an emergency, pour warm water on it to melt the ice. Once the frozen spots loosen, try to open it.
- › Do not install or paste any ornaments onto the tailgate strut.
- › Do not pull sideways the tailgate, otherwise, the strut may be bent and deformed.

i Notice

- › When the ambient temperature is lower than 0°C, the tailgate strut may not be able

i Notice

to automatically push the tailgate up. In this case, you can manually lift the tailgate to open it.

- › Do not install heavy accessories on the tailgate. This can prevent the strut from smoothly pushing the tailgate up.
- › The telescopic movement of the tailgate strut needs oil-assisted lubrication, so it is normal that there may be oil stains near the dust cover of the strut.

Emergency unlock

1. Enter the vehicle and pry down the emergency cover plate at the bottom of inner side of the tailgate using a mechanical key

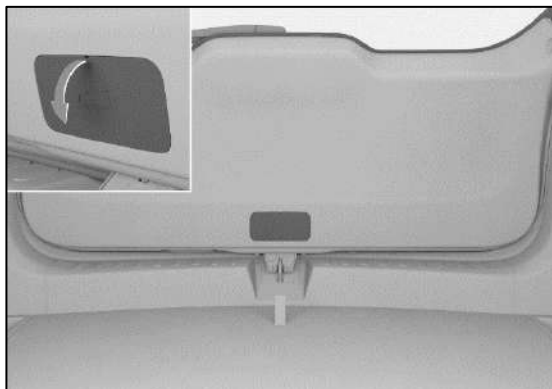

B58F2872692D

Please refer to Replacement of Key Battery for the method to obtain the mechanical key. (▷ Page 20)

2. Toggle the emergency opening device counter-clockwise in the direction shown in the figure to open the tailgate.

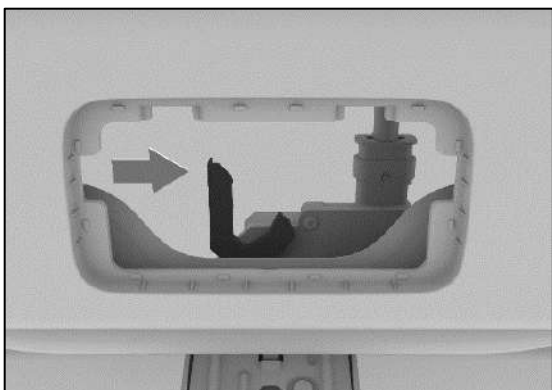

20BDF6834396

i Notice

- › If you need to move the emergency opening device with your hands, please try not to touch the sheet metal parts to avoid scratching.
- › If you need to use this method to open the tailgate, it means that the vehicle has malfunctioned. In this case, please go to the authorised service centre for maintenance as soon as possible.

Child safety lock

If there are child passengers within the vehicle, we recommend that they be seated in the comparatively safer rear seats where child safety locks are available with the corresponding vehicle doors to prevent inadvertent opening of the vehicle doors.



E1DOC7587D86

Move the lever in the direction of the arrow to activate the child safety lock. Move the lever in the opposite direction to deactivate the child safety lock.

⚠ Warning

Only the rear doors are equipped with child locks. If a child is alone in the rear row, please activate the child locks on both rear doors at the same time to avoid accidents caused by accidental opening of the doors.

i Notice

After the child lock is activated, the door can only be opened by pulling the door handle from outside the car.

Unlocking after flameout

After the power supply mode changes from ON to OFF mode, all vehicle doors and the tailgate will be automatically unlocked. The ignition off and unlock function can be activate or deactivated via

[Vehicle Settings] →[In-car] →[Body] →[Flameout Unlocking] on the multimedia display screen.

Auto driving lock

All the doors and the tailgate are locked automatically when the vehicle speed exceeds 15 km/h.

Vehicle speed of the auto driving lock can be set via [Vehicle Settings] →[In-car] →[Body] →[Speed locking] on the multimedia display screen.

Notice

Make sure that all doors and the tailgate are completely closed before driving.

Automatic resetting

When the engine hood is closed and all the doors and the tailgate are locked, if the power supply mode and the state of all the doors and the tailgate do not change within 30 seconds after the doors from outside the vehicle are unlocked (except the mechanical key), all the doors and the tailgate will be automatically locked.

Automatic unlock upon Collision

With the power in ON mode, when the system detects a collision, all doors will be unlocked automatically.

Anti-misoperation lock

When the last door is closed with the driver's door locked, all locked doors will be unlocked automatically.

Anti-misoperation lock

When the last door is closed with the driver's door locked, all locked doors will be unlocked automatically.

Vehicle equipment

Please note that this manual contains all the standard equipment, country-specific equipment and special equipment for this model series. Thus, some equipment or features described in this manual may not be installed onto your vehicle or are only available in some markets. For further configuration information, please refer to relevant sales information or consult with your distributor selling the vehicle to you.

Window switch

Driver's window switch

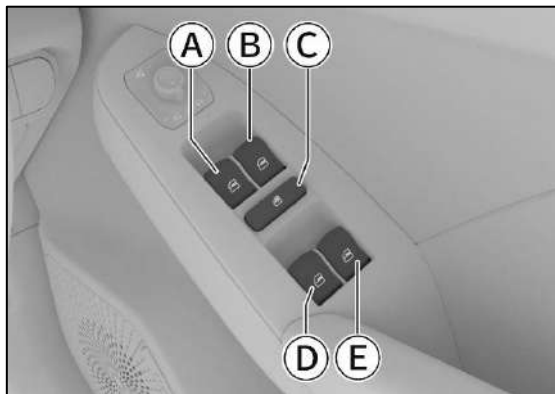

672B7229D35B

- (A) Front passenger's side window
- (B) Driver's window switch
- (C) Window lock switch
- (D) Rear window switch (L)
- (E) Rear window switch (R)

Manual operation

To open or close the vehicle windows, press or pull up and hold the corresponding switch until the vehicle window reaches the required position.

⚠ Warning

Before closing the vehicle window, make sure that all occupants' heads and hands have left the vehicle window space, otherwise, it could cause an extremely serious injury.

One-push raising or lowering

Press the vehicle window switch until it exceeds the pressure point, and then release the switch.

At this time, the vehicle window will be automatically opened completely. If you want to stop it halfway, you can just pull up the switch. Pull up the vehicle window switch until it exceeds the pressure point and then release the switch. At this time, the vehicle window will be automatically closed completely. If you want to stop it halfway, you can just press the switch.

i Notice

In some models, only the driver's window is equipped with the one-button vehicle window opening and closing function.

⚠ Caution

In a low temperature environment, ice may freeze between the vehicle window glass and the vehicle window frame, and the glass may fail in ascending and descending due to this reason. Do not repeat the operation by force at this time to avoid damage to the lifting mechanism. After the temperature inside the vehicle rises and the ice on the glass thaws, the glass will ascend and descend properly.

Vehicle window locking

When the vehicle window locking switch is pressed, the corresponding vehicle window cannot be controlled by the vehicle window switch on the rear door. Pressing the vehicle window locking switch again will recover the function of the rear vehicle window switch.

⚠ Warning

When there are children in the vehicle, it is recommended that they should sit in the relatively safe rear seats and the vehicle window locking function should be enabled.

Passenger's side window Switches

On the armrest of the passenger's side door, there is a window switch which can be used to open or close the corresponding window.

Thermal protection function

Thermal protection may be triggered to protect the glass lifter motor after repeated operation of the window switch. At this time, the window switch will temporary failure. The window switch automatically returns to normal after the lifter motor cools down.

Anti-pinch function

In the process of automatic vehicle window closing, if a foreign object is sensed between the vehicle window frame and the vehicle window, the vehicle window will stop closing and automatically descend for a certain distance.

i Notice

Due to different vehicle configurations, only the driver side vehicle window of some vehicles is equipped with this function.

⚠ Warning

- > **Never test the anti-pinch function with any part of your body.**
- > **At the moment when the vehicle window is complete closed, the anti-pinch function will not work if something gets stuck.**

i Notice

Under severe conditions, such as low temperature and severe bumping, the anti-pinch function may be triggered in the process of window glass ascending, and the vehicle window cannot be closed smoothly. At this time, please pull up the vehicle window switch till it exceeds the pressure point to close the vehicle window.

Delay function

The vehicle windows can still be operated within a few seconds after the power supply is switched to OFF.

i Notice

Some models are equipped with this function on the driver side window only, depending on the vehicle model.

Speed Closing

With the power supply in OFF mode, when all the doors and back door are closed, press and hold the lock button on the key or the lock sensor on the door handle to automatically close the windows.

Press the key unlock or lock button to stop rising window if they are going up automatically.

i Notice

If an obstacle between the window glass and the window frame is found during the automatic ascending of the window glass, the anti-pinch function will be triggered, and the driver must confirm that the windows are completely closed before leaving.

Initialization

When errors occur in one-push raising or lowering function, you can reset it through the following operations:

1. Switch the power to OFF mode.
2. Pull up the window switches equipped with one-push raising or lowering function beyond the pressure point until the window is completely closed and then hold for about 3 seconds.
3. Operate the window switch again so that the window goes through the one-push raising and one-push lowering.

i Notice

When the one-push raising or lowering function is disordered or every time the battery is disconnected and re-energized, the windows with one-push function need to be initialized.

Vehicle equipment

Please note that this manual contains all the standard equipment, country-specific equipment and special equipment for this model series. Thus, some equipment or features described in this manual may not be installed onto your vehicle or are only available in some markets. For specific configuration information, please refer to relevant sales materials or consult your vehicle dealer.

Opening and closing the sunroof



11C12A9BF507

Manual operation

- › Press upwards and hold the sunroof button to tilt the sunroof to the maximum angle and stop; press and hold the button again to gradually open the sunroof.
- › Press downwards and hold the sunroof button to gradually close the sunroof.
- › To make the sunroof stop in the midway, release the button.

Automatic operation

- › Press upwards and release the sunroof button to tilt the sunroof automatically to the maximum angle and stop; press and release the button again to automatically open the sunroof to the proper position; press and release the button again to open the sunroof automatically and completely.
- › Push downwards and release the sunroof button to automatically close the sunroof.
- › To make the sunroof stop in the midway, press the button again.

⚠ Warning

- › Do not put your hand or heads out of the sunroof when the vehicle is moving. If objects are outside the vehicle when a emergency braking requirement, it may cause serious personal injury or even death.
- › When closing the sunroof, be careful not to clip other people's hands, heads and neck etc. to prevent serious personal injury.
- › Do not allow children to operate the sunroof.

Opening/closing of sunshade.



E10A12E86AAC

Manual operation

- › Press and hold the sunshade button upward to gradually open the sunshade.
- › Press and hold the sunshade button downward to gradually close the sunshade.
- › To make the sunshade stop in the mid-way, release the button.

Automatic operation

- › Press the sunshade button upward and then release it, and the sunshade will open automatically.
- › Press the sunshade button downward and then release it, and the sunshade will close automatically.
- › To make the sunshade stop in the mid-way, press the button again.

⚠ Warning

- › When closing the sunshade, be careful not to clip other people's hands, heads and neck etc. to prevent serious personal injury.
- › Do not allow children to operate the sunshade.

⚠ Caution

Do not squeeze the sunroof sunshade with force to prevent the sunshade from falling off or being damaged.

When parking a vehicle for a long time, it is suggested to close the sunroof sunshade to prevent the inside decoration from being damaged due to the inside high temperature if it is exposed to the sun for a long time.

Thermal protection function

Thermal protection function may be triggered to protect the sunroof motor after repeated operation of the sunroof switch. At this time, the sunroof function will be temporarily disabled, and the sunroof will fail to be operated.

The sunroof switch will automatically return to normal after the motor cools down.

Linkage function

When the sunshade is in the close position, in the process of opening the sunroof, the system will automatically adjust the opening degree of the sunshade according to the opening of the sunroof.

Anti-pinch function

If the sunroof or sunshade encounters an obstruction during the automatic closing, it will stop closing and return to a certain distance.

⚠ Warning

- › Do not attempt to use any part of your body to test the anti-pinch function.

- › At the moment when the sunroof and sunshade are completely closed, the anti-pinch function will not work if any object is stuck.

Delay function

Within a few seconds after switching the power to OFF mode, the sunroof and sunshade still can be operated.

One-click closing

With the power supply in OFF mode and all the doors and the tailgate closed, press and hold the lock button on the key or the lock sensor on the door handle to automatically close the sunroof.

⚠ Warning

Make sure that the heads, hands and necks of all passengers are away from the window before closing the sunroof, and then use the one-click closing function. Otherwise, serious injury may occur.

i Notice

If an obstacle between the window and the window frame is found during the closing of the window, the anti-pinch function will be triggered. The driver must confirm that the windows are completely closed before leaving.

Automatic sunroof closing

- › When the power supply is in OFF mode, if the rainfall and light sensor senses rain or snow, etc., the sunroof will be automatically closed.

i Notice

In case of the little rain, the sunroof may not be closed automatically. It must be confirmed that the sunroof is completely closed before leaving.

- › The sunroof closes automatically when the speed exceeds 120 km/h for more than 3 s during driving.

i Notice

- › If the vehicle speed drops below 120 km/h within 3 s, the sunroof will not be closed automatically.
- › If the vehicle speed exceeds 120 km/h during sunroof operation, the sunroof will remain in its original state of operation and will not trigger the automatic sunroof closing function.
- › If the sunroof switch is operated during automatic sunroof closing, the automatic sunroof closing function will be interrupted.
- › If the automatic sunroof closing function has been triggered or interrupted while driving, the vehicle must accelerate again from a standstill to over 120 km/h for more than 3 s before the automatic sunroof closing function can be triggered again.

Initialization

If the system is in disorder, it can be recovered through the following operations:

1. Close the sunroof and sunshade completely, press and hold the sunroof button until the sunroof and the sunshade jitter and then release the button.
2. Press and hold the sunroof button again within 5 seconds until the sunroof and sunshade complete the movement from being open to full closed, then release the button, and the initialization is complete.

If the sunroof rebounds during the closing process, it can be forced to initialize through the following operations:

1. When the sunroof rebounds, press and hold the sunroof button immediately, and continue to keep pressing and holding the sunroof button after the rebound is over, until the sunroof is completely closed and jitters once, and then release the button.
2. Press and hold the sunroof button again within 5 seconds until the sunroof completes the movement from being open to fully closed, then release the button, and the sunroof initialization is completed.

If the sunshade rebounds during the closing process, it can be forced to initialize through the following operations:

1. First close the sunroof completely.
2. When the sunroof rebounds, press and hold the sunroof button immediately, and continue to keep pressing and holding the sunroof button after the rebound is over, until the sunroof is completely closed and jitters once, and then release the button.
3. Press and hold the sunroof button again within 5 seconds until the sunroof completes the movement from being open to fully closed, then release the button, and the sunroof initialization is completed.

Refuelling

Vehicle equipment

Please note that this manual contains all the standard equipment, country-specific equipment and special equipment for this model series. Thus, some equipment or features described in this manual may not be installed onto your vehicle or are only available in some markets. For specific configuration information, please refer to relevant sales materials or consult your vehicle dealer.

Refueling method

1. When the driver side door is unlocked, press the end of the fuel tank door near the rear of the vehicle, to open the fuel tank door slightly.
2. Turn the fuel tank cap counterclockwise to open it, and fix the cable of the fuel tank cap on the fuel tank door to avoid soiling the vehicle body.

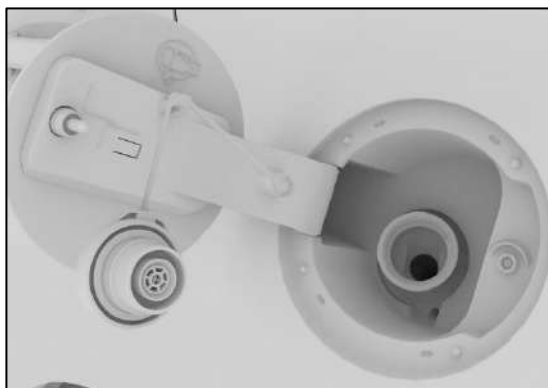

EF17758C245F

⚠ Warning

- › When loosening the fuel cap, do not continue if you hear a whooshing sound. Once the sound disappears, you can open it slowly. In hot weather, high-pressure fuel may be sprayed from the tank port due to large internal pressure, resulting in personal injury.
- › Take note of such matters during refueling: The engine must be shutdown. No smoking or naked flames are allowed in the vicinity of the vehicle.

Making and answering phone calls are forbidden. Adhere to all precautions posted at the gas station.

⚠ CAUTION

- › Do not fill too much fuel. It is recommended that you stop at the first automatic stop of the filling gun. Otherwise, fuel can easily enter into the carbon canister which could shorten its service life.
- › Do not allow fuel to splash on the vehicle while refueling, as this may corrode the painted surfaces.
- › Use only designated fuels.

3. After refueling, put the fuel tank cap back to its original position and rotate it clockwise until a "click" sound is heard, indicating that the fuel tank cap has been installed in place.

i Notice

The fuel tank cap should be installed properly, otherwise the engine fault indicator may be turned on.

4. Close the fuel tank door.

Fuel information

Item	Data
Fuel specification	E10/E20
Fuel tank capacity [L] (reference value)	55±1.05

Engine hood

Vehicle equipment

Please note that this manual contains all the standard equipment, country-specific equipment and special equipment for this model series. Thus, some equipment or features described in this manual may not be installed onto your vehicle or are only available in some markets. For specific configuration information, please refer to relevant sales materials or consult your vehicle dealer.

Opening

1. Pull the hood handle located below the instrument panel. The hood will pop open gently.

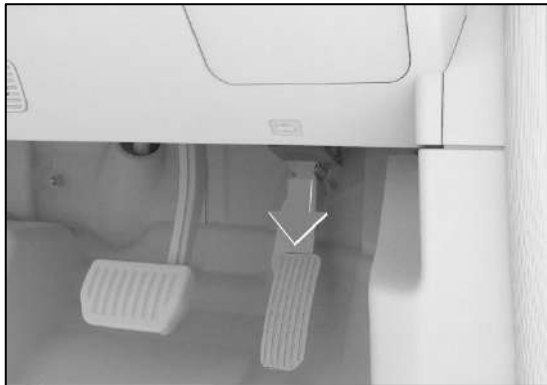

5B39588D8B2A

2. Lift the engine hood slightly. Put your hand into the gap and pull the latch of engine hood in the direction of the arrow to open the engine hood.

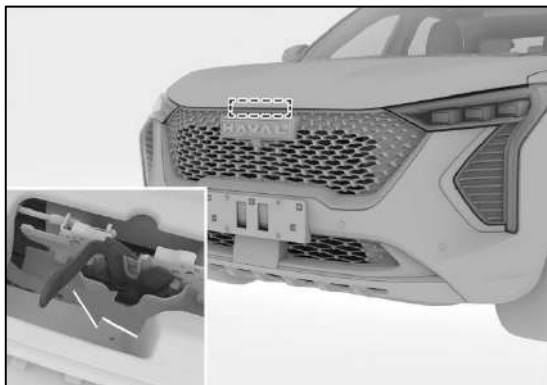

500A82FA9C93

3. Take the strut out of the bracket and insert the front end into the recess in the hood to prop it up.



740C295434FF

i NOTICE

When the driving system of the vehicle is ready (the indicator **READY** in the combination instrument lights up) the engine will be started automatically with shutdown prohibited after the compartment cover is opened.

Close

1. Lift the hood up slightly.
2. Remove the strut and return the hood to its original position.
3. Release the engine hood at a height of about 30 cm from the engine hood lock and allow the hood to descend without aid.
4. Make sure the engine hood is fully locked.

⚠ WARNING

Make sure that the engine hood is fully closed and secured prior to driving. Otherwise it may open unexpectedly during vehicle running that leads to accident.

⚠ Caution

Before closing the engine hood, make sure that there is no debris left inside the engine compartment.

Vehicle equipment

Please note that this manual contains all the standard equipment, country-specific equipment and special equipment for this model series. Thus, some equipment or features described in this manual may not be installed onto your vehicle or are only available in some markets. For specific configuration information, please refer to relevant sales materials or consult your vehicle dealer.

Headrest

Headrest adjustment

When the headrest center height is aligned with the top of the driver's or passenger's ears, it is at maximum efficiency.

Warning

It is forbidden to adjust the headrest during driving.

Front seat headrest

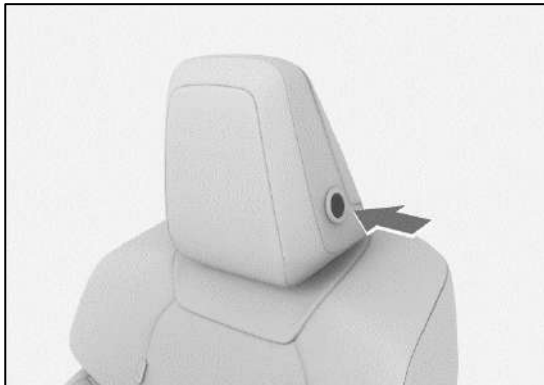

FED3BD68F29E

Rear seat headrest

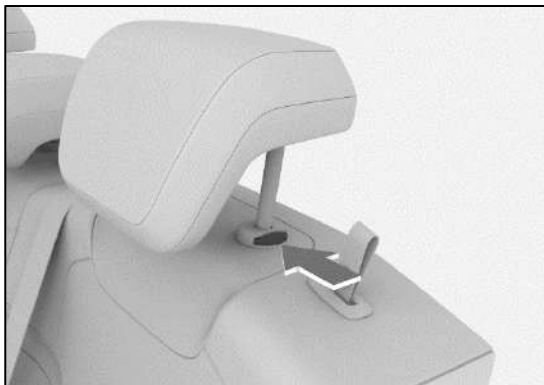

E1623383F02D

- › To raise the headrest, directly pull it upwards to the desired position.
- › To lower the headrest, press down on the headrest while pressing and holding the headrest adjust button until the headrest reaches the desired position.

Notice

The lowest position of the headrest is not its use position. The headrest must be ascended to the locked position before use.

Notice

After adjusting the headrest, press the headrest to make sure it is locked firmly.

Remove headrest

Front seat headrest

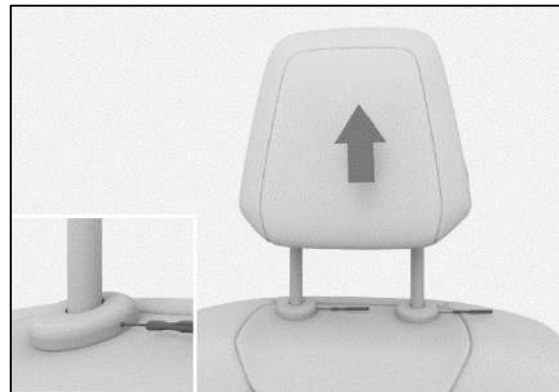

A91ABD45C88F

After raising the headrest, one person uses two thin screwdrivers to press the keyhole while the other person can pull the headrest upward.

If necessary, adjust the seat backrest so that the headrest can be removed.

Rear seat headrest

To remove the headrest, press and hold the headrest adjust button, and remove the headrest. If necessary, adjust the seat backrest so that the headrest can be removed.

⚠ Caution

After the headrest is installed, push it up or down to make sure that it has been locked in place.

⚠ Warning

It is forbidden to drive without the headrest. Otherwise, if there is a collision, your neck will be greatly impacted, resulting in serious injury and even death.

Front seat

Manual seat adjustment

⚠ Warning

- › Never adjust the seat when driving.
- › Before driving, please adjust the seat to a position convenient for correct driving. Otherwise, it may easily cause incorrect operations and may even lead to accidents, and the safety efficiency of seat belts, airbags, headrest and other devices cannot be effectively used.
- › Do not tilt the seat backrest excessively because your body may slip out of the safety belt during collision. The seat belts can provide the best protection only when you sit up straight and lean against the seat backrest.

Slide the seat back and forth to the required position, and release the adjustment lever.

i Notice

After adjusting the seat, make sure that it is locked firmly.

Backrest inclination angle adjustment



90ABBE946192

Move your body tightly against the backrest, pull up the inclination adjustment handle of the seat backrest, lean back to adjust the backrest to the required angle, and release the adjustment handle.

⚠ Caution

Please ascend the backrest inclination adjustment handle completely before adjusting the backrest. Otherwise, the seat may be subject to mechanical failures.

Forwards/backwards adjustment of the seats



OA3A8DB18BA7

Pull up the seat position adjustment lever,

Seat height adjustment



995EE0679287

- › To ascend the seat, repeatedly pull up the seat height adjustment handle.
- › To descend the seat, repeatedly press down the seat height adjustment handle.

i Notice

Some functions only apply to the driver's seat.

Power seat adjustment

⚠ Warning

- › Never adjust the seat when driving.
- › Before driving, please adjust the seat to a position convenient for correct driving. Otherwise, it may easily cause incorrect operations and may even lead to accidents, and the safety efficiency of seat belts, airbags, headrest and other devices cannot be effectively used.
- › Do not tilt the seat backrest excessively because your body may slip out of the safety belt during collision. The seat belts can provide the best protection only when you sit up straight and lean against the seat backrest.

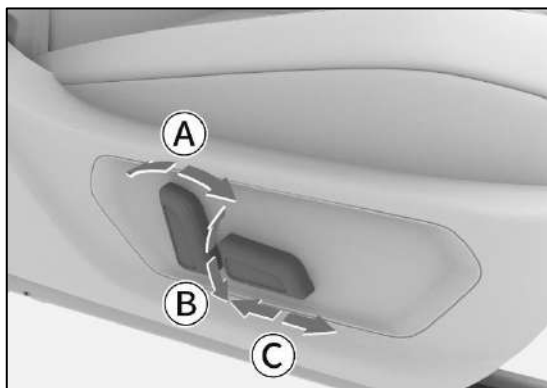

5FA061C108D3

- (A) Backrest inclination angle adjustment
- (B) Seat height adjustment
- (C) Forwards/backwards adjustment of the seats

i Notice

Some functions only apply to the driver's seat.

Driver seat ventilation function

Touch the icon  button at the bottom of the air-conditioning setting interface to set the ventilation functions of the seat.

Rear seats

Rear seat adjustment

Backrest folding

After the rear seat backrest is folded, larger storage space can be obtained. The left or right part of the backrest can be folded separately.

i Notice

- › Before folding, adjust the headrest to an appropriate position to avoid interference with the seat cushion or front seat.
- › Put the seat belt back in place to avoid interference when folding the backrest.



5E5D62331BE1

The unlocked backrest can be folded forwards by pulling up the unlocking handle at the top of the backrest.

⚠ CAUTION

- › Remove all objects from the seat before folding the seat backrest.
- › When the backrest is folded, do not put heavy objects on it.

⚠ WARNING

- › It is forbidden to adjust or fold the seat when driving the vehicle.
- › No one is allowed to sit on a folded seat backrest or in the luggage area.
- › Children are prohibited from entering the luggage area.

Backrest restoring

1. Adjust the seat belt to prevent it from getting caught under the seat when the backrest is restored.
2. Pull up the backrest and return it to the original position for use. Shake the backrest gently from front to back to make sure that the backrest is locked into place.

Rear armrests



87B51A25E8E3

Pull the rope outwards to lower the rear armrests to provide elbow support for the rear passengers and make the arms feel more comfortable.

Rearview mirror

Vehicle equipment

Please note that this manual contains all the standard equipment, country-specific equipment and special equipment for this model series. Thus, some equipment or features described in this manual may not be installed onto your vehicle or are only available in some markets. For specific configuration information, please refer to relevant sales materials or consult your vehicle dealer.

Interior rearview mirror

Manual anti-glare inside rear-view mirror

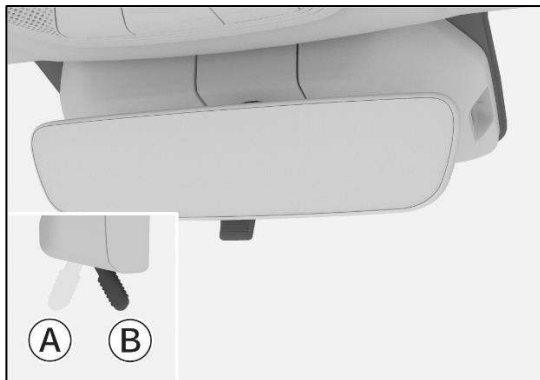

OBE427951FA7

(A) Normal position

(B) Anti-glare position

Toggle the handle to the rear of the vehicle to switch to the anti-glare position. The reflection of the headlamp of vehicle behind can be reduced at that position.

Automatic anti-glare inside rearview mirror

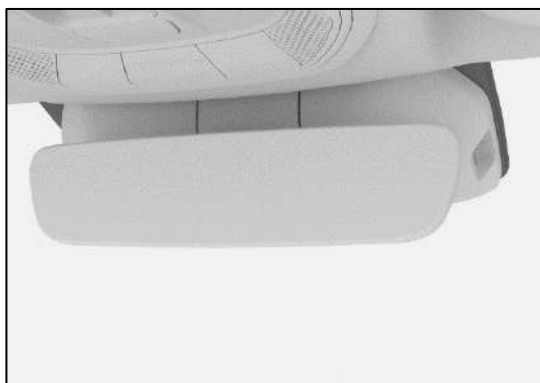

41251C7DDFE5

The inside rearview mirror will automatically reduce the reflection according to the light intensity of the headlamp of the vehicle behind.

Side mirrors

Outside rearview mirror adjustment

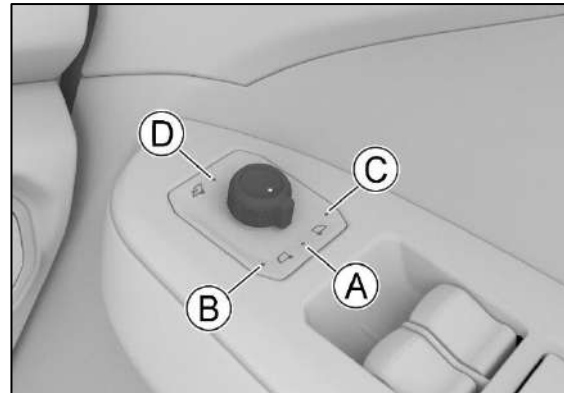

14B6FA85F9AO

(A) Original position

(B) Select the left outside rearview mirror

(C) Select the right outside rearview mirror

(D) Fold outside rearview mirror

Mirror adjustment

1. Rotate the outside rearview mirror adjustment knob to select the left or right outside rearview mirror.
2. Turn the knob forward or backward, to the left or the right, and you can adjust the left or right outside rearview mirror lens.
3. After adjustment, reset the outside rearview mirror adjustment knob to the initial position.

⚠ WARNING

Do not adjust the rearview mirrors while driving. Otherwise, errors in control can lead to accidents and serious injuries or death.

Electric folding

Turn the adjustment knob to the  outside rearview mirror folding position and the outside rearview mirror will be folded automatically.

Turn the adjustment knob to a different position and the outside rearview mirror will deploy automatically.

Manual folding



AED8A21AA2F9

Move the outside rearview mirror in the direction indicated by the arrow and it can be folded.

It is mandatory to have the outside rearview mirrors back in their pre-fold positions prior to driving.

⚠ CAUTION

For electric folding outside rearview mirrors, do not fold them manually. Otherwise, the internal structure of the rearview mirror may be damaged.

Auto folding when locking the vehicle

You can set rearview mirror fold mode on multimedia display screen via [Vehicle Setting] → [In-Car] → [Body] by .

When the rearview mirrors is [Auto] , it allows you to link its folding and deploying to the locking and unlocking of the doors.

Steering wheel

Vehicle equipment

Please note that this manual contains all the standard equipment, country-specific equipment and special equipment for this model series. Thus, some equipment or features described in this manual may not be installed onto your vehicle or are only available in some markets. For specific configuration information, please refer to relevant sales materials or consult your vehicle dealer.

How to adjust



BC934B8CAFFE

1. Release the adjustment lever beneath the steering wheel.
2. Adjust the steering wheel to align it to your chest and make sure you can see all the instruments and indicators on the combination instrument.
3. After adjusting, retract the lever back to lock the steering wheel.

⚠ WARNING

- › Adjustment of steering wheel during vehicle running is forbidden. Otherwise, serious injury or death may result from an accident caused by control errors.
- › You must ensure that the steering wheel is locked firmly in place after adjusting it. Otherwise, serious injury or death may result from an accident caused by sudden movement of the steering wheel.

Horn

Press the horn mark on the steering wheel or its surrounding area and the horn honks.

Vehicle equipment

Please note that this manual contains all the standard equipment, country-specific equipment and special equipment for this model series. Thus, some equipment or features described in this manual may not be installed onto your vehicle or are only available in some markets. For further configuration information, please refer to relevant sales information or consult with your distributor selling the vehicle to you.

Roof rack

To install a luggage rack on the roof rack, please read carefully the installation manual accessory of the luggage rack.

i NOTICE

When the luggage rack is installed or used for carrying items, relevant requirements of local traffic regulations should be observed.

Roof rack bearing capacity

The maximum load weight of the roof rack is 50 kg; the maximum load weight of the roof rack is 35 kg when the vehicle is decelerating rapidly.

i NOTICE

The load weight of the roof rack includes accessories such as the beam and other accessories.

⚠ WARNING

- › Items on the roof luggage rack must be secured firmly in place. Otherwise, there is a risk of an accident.
- › Loading goods on the roof luggage rack will raise the vehicle's center of gravity. Avoid high speed driving, sudden startup, sharp turns, emergency braking or abrupt operation, as this may cause loss of control or overturn of the vehicle due to incorrect operation of the vehicle, resulting in serious injury or death.
- › When rather heavy or large objects are loaded on the roof luggage rack, changes in the vehicle's center of mass and wind resistance may affect its driving performance, and there is a risk of an accident. Therefore, you must adjust your driving style and speed according to the specific circumstances.
- › Drive at low speed in lateral wind. The vehicle's profile and its high center of gravity make it more sensitive to lateral gust, and reducing the vehicle speed will make it easier to control.
- › Do not overspeed, jolt, make sharp turns, hit objects, etc. when driving offroad or in uneven terrain. This can cause loss of control or overturn of the vehicle, resulting in serious injury or death, as well as serious damage to the suspension and chassis of the vehicle.
- › Do not cross steep slopes, and it is better to drive straight up or down. The vehicle is more likely to roll over than to roll forward or backward.
- › The roof luggage rack can only be used with the sunroof closed. Otherwise, the roof luggage rack or the items loaded on it may cause injury to passengers.

Light Control

Vehicle equipment

Please note that this manual contains all the standard equipment, country-specific equipment and special equipment for this model series. Thus, some equipment or features described in this manual may not be installed onto your vehicle or are only available in some markets. For the further configuration information, please refer to relevant sales information or consult with your distributor selling the vehicle to you.

Light setting

The light settings can be made through the multimedia display.

Type I



1874B6CB6F1F

Type II

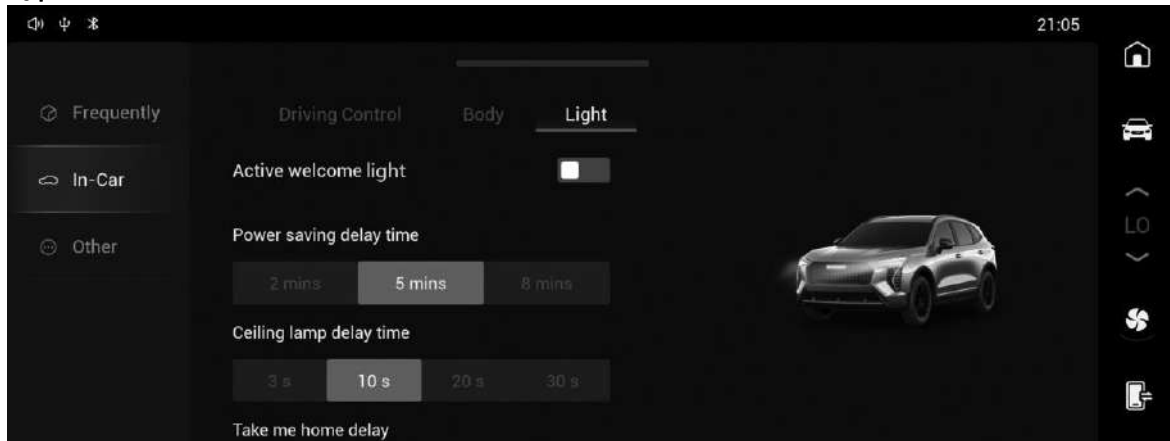

BEEID687FF3C

- › Active Courtesy: the active courtesy function can be activated or deactivated.
Active welcome light: the active courtesy function can be activated or deactivated.
After the active courtesy function is activated and when the main lamp switch is in the AUTO position, the position lamp and the low beam headlamp will be on for a period of time when the door is unlocked.
- › Power Saving Delay Time: the power saving delay function can be set.
After the power supply mode is switched to OFF mode, if the power supply mode, door lock and hazard warning light switch status do not change within the set time range, the power saving function will be automatically turned on to save power.

- 
- › Ceiling Lamp Delay Time: the turning on time and the delay off time of the interior lamp can be set.
 - › Take Me Home Delay: the continuous lighting time of the position lamp and the low beam headlamp can be set after the “take me home” function is triggered.
 - › Sports Mode Light: the sport mode light function can be activated or deactivated.
Sports mode light setting: the sport mode light function can be activated or deactivated.

⚠ CAUTION

Do not use the exterior lighting for a long time when the vehicle is not started. Otherwise, the undervoltage battery may be caused.

Light control combination switch

Main lighting switch

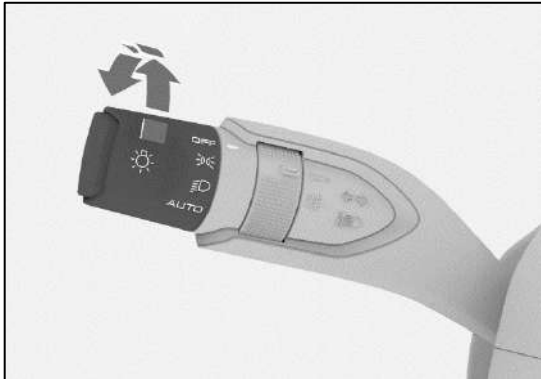

3927AC98287D

- › Turn the main lamp knob to the width lamp position  to turn on the position lamp and the license plate lamp.

⚠ CAUTION

Do not use the position light to replace the low beam headlight in the driving. Otherwise, there is a risk of an accident.

The position lights are not bright enough to illuminate the road in front of the vehicle or allow other vehicles and pedestrians to see the vehicle. Therefore, turn on the low beam headlight when the weather is dim or visibility is poor.

- › Turn the main lamp knob to the low beam headlamp position  to turn on the low beam headlamp and keep the position lamp and the license plate lamp illuminated.
- › Turn the knob of the main lamp knob to the AUTO position. The width lamps and low beam headlamps will be turned on or off automatically according to the brightness of the surrounding environment.

⚠ CAUTION

- › When visibility is affected in the day due to fog, the lights may not light up automatically. Please turn on the lights manually in this case.

- › Automatic light control can only assist the driver. At all times the driver should be responsible for the lighting of the vehicle.
- › Turn the main lamp knob to the OFF position to turn off all vehicle lamps.

Fog lamp switch



DD2CEF12CC39

When the low beam headlamp is illuminated, turn the fog lamp knob to the rear fog lamp position  repeatedly to turn the rear fog lamp on or off. When released, the knob will automatically return.

Turn signal and lane change signal

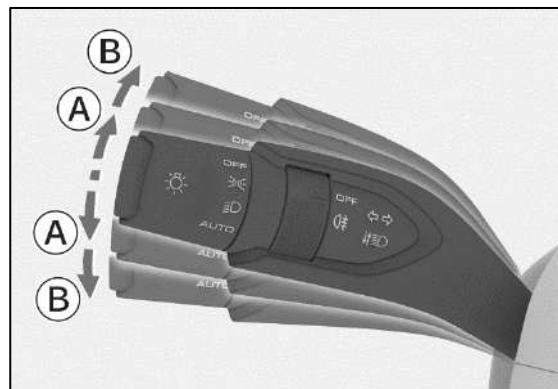

DB397E53DFCA

(A) Lane change signal

(B) Turn signal

- › Lane change signal: Pull up or push down the light control combination switch gently and release it, then the light control combination switch will return automatically and the corresponding turn signal lamp will flash 3 times.

- › Turn signal: Pull up or push down the light control combination switch and release it, then the light control combination switch will not return automatically and the corresponding turn signal lamp will flash continuously.

High/low beam manual switch

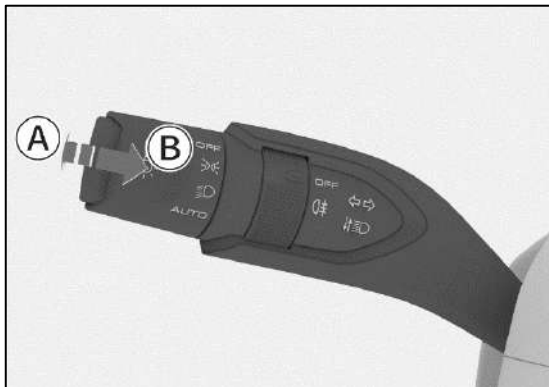

44B9EE7AB515

- (A) High beam headlamp on
- (B) High beam headlamp flashes
- › When the low beam headlamp is on, press the light control combination switch in a direction away from the steering wheel to turn on or off the high beam headlamp; when you release the light control combination switch, it returns automatically.
- › The high beam headlamp turns on when you pull the light control combination switch up in a direction close to the steering wheel; when released, the light control combination switch automatically returns and the high beam headlamp goes out. You can repeat this operation to make high beam headlamp flash.

Follow me home function

With the power supply in OFF mode and the main lamp switch in the automatic light position, if the current light intensity meets the conditions for the low beam headlamp to be on, the position lamp and the low beam headlamp will automatically illuminate for a

period of time after all the doors and the tailgate have been successfully locked from the outside of the vehicle (except for locking by the mechanical key) to ensure that you can leave the vehicle in the dark.

Daytime running lamps (DRL)

To allow other drivers to see your vehicle more clearly, the daytime running lamps automatically light up when the vehicle is started. The daytime running lamps will go out when the following conditions are triggered

- › When the headlamp is turned on.
- › When the left or right turn signal lamp is on, the daytime running lamp

⚠ WARNING

The daytime running lamps are not designed for the needs of night-time driving.

Emergency braking warning

When the speed of the vehicle exceeds 50 km/h, the turn signal lamp will flash if you perform emergency braking at that time.

Emergency hazard flashers



BBCBB74943DE

In the event of vehicle failure or traffic accident, turn on the emergency flashers to warn other vehicles.

Press the switch to turn on or turn off the emergency flashers.

Light height adjustment



C45DFIF3D6AF

The headlight beam height is adjusted according to the number of passengers and the load of the vehicle.

- › Turn the knob upwards to raise the height of the headlight beam.
- › Turn the knob downwards to lower the height of the headlight beam.

Instrument brightness adjustment



26687162ACD7

When the position lamps are turned on, you can adjust the brightness of the instrument and the vehicle back lamps.

- › Press the upper part of the button: the instrument and the vehicle back lamps are turned on.
- › Press the lower part of the button: the instrument and the vehicle back lamps are darkness.

Interior lights

Reading lamps



⚠ CAUTION

Do not use the interior lamps for a long time when the vehicle is not started.

Otherwise, it may lead to drain battery.



62BFEC4C6806

- › Press the  reading lamp main switch to turn on or turn off the reading lamps.
- › Press the  door-control function enabled, the reading lamp will turn on or turn off automatically according to the door condition.

Center roof lamp





AE413216A945

- › Push the switch to OFF position: roof lamp off.
- › Push the switch to middle position to turn on the door-control function; the roof lamp will turn on or turn off automatically according to the door condition.
- › Push the switch to ON position: roof lamp on.

Side roof lamp



272173CA18CF

Press the left side roof lamp switch  or the right side roof lamp switch  to turn on or turn off the corresponding roof lamp.

With the door-control function enabled, the roof lamp will turn on or turn off automatically according to the door condition.

Luggage-area light

When the back door is open or closed, the luggage-area lights turn on or off automatically.

Wiper controls

Vehicle equipment

Please note that this manual contains all the standard equipment, country-specific equipment and special equipment for this model series. Thus, some equipment or features described in this manual may not be installed onto your vehicle or are only available in some markets. For further configuration information, please refer to relevant sales information or consult with your distributor selling the vehicle to you.

Electric wiper

Front wiper

Front wiper position

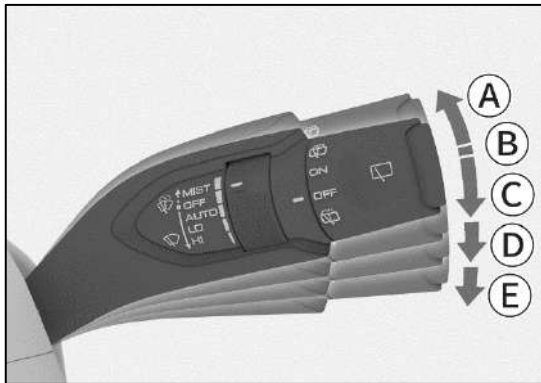

080E92635C27

- (A) Front wiper mist operation (MIST)
Pull the wiper control combination switch upwards to the MIST position. Once released, the lever will automatically return to its original position. The front wipers will operate once.
- (B) Turn off front wiper (OFF)
- (C) Intermittent wipe (INT)
- (D) Low speed (LO)
- (E) High speed (HI)

⚠ CAUTION

- > If the surface of the windshield glass is dirty or there are foreign objects on the windshield (snow, gum, etc.), please clean it first and remove the foreign objects, otherwise the wiper blade or the internal structure of the wiper may be damaged.
- > Prior to using the wiper in the cold season, you shall ensure to check if the wiper blade is frozen on the windshield glass. If the wiper blade has been frozen on the windshield, you should wait to use it until it has defrosted, otherwise the wiper blade and wiper motor may be damaged.
- > Should the wiper stop working due to issues such as accumulated snow, please turn off the wiper and park the vehicle in a safe spot. Then remove accumulated debris so that the wiper may continue to operate normally.

Adjustment of intermittent wiping frequency



EB24582437CE

Turn the adjustment knob to change the intermittent time in order to adjust the wiping frequency of the front wiper at the intermittent wiping position.

Washing function

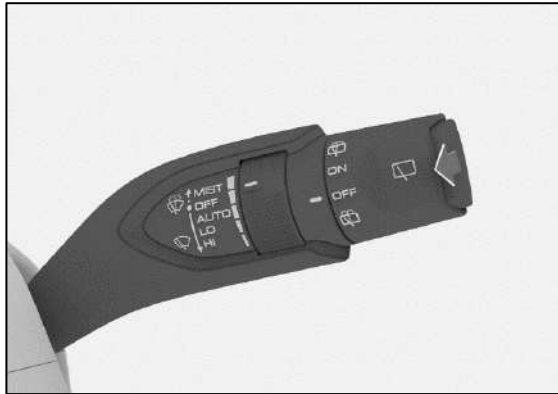

930465496923

Pull the wiper control combination switch up vertical to the steering wheel. The front wiper will clean the front windshield with windshield washer fluid.

⚠ CAUTION

- › Avoid prolonged use of the washer. Otherwise it may damage the washing motor.
- › To protect the washing motor, the washer may automatically shut down after a period of continuous operation.
- › Always check the liquid level of the washer fluid tank and add it in time. In the cold season, add the appropriate washing fluid to ensure that the washing fluid does not freeze. Otherwise, the washer will not only lose the washing function, but also freeze the relevant parts.

Rear wiper

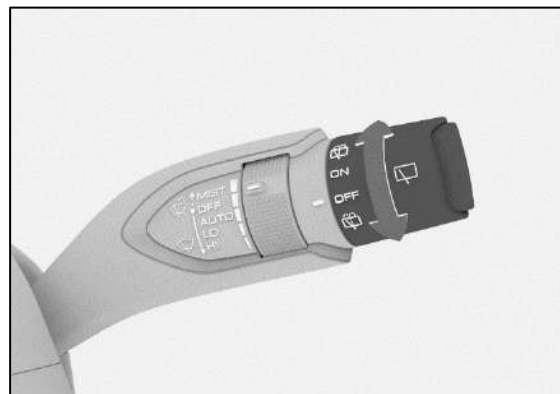

46A82A16B535

- › Turn the rear wiper control knob to the ON position and the rear wiper will turn on.
- › Turn the rear wiper control knob to the rear windscreen cleaning position  and hold. The rear wiper will wipe the rear windscreen using screen washer. Release the control knob and it will return automatically to its previous position.
- › Turn the rear wiper control knob to the OFF position to turn off the rear wiper.

⚠ CAUTION

- › Do not use products that can produce coatings on the windscreen (e.g. cleaning solutions for crystal plating or coating, glass coatings, etc.). Otherwise, abnormal vibration and noise may occur during scraping by the wiper.
- › Do not let the wiper blade come into contact with products such as oil-based cleaning agents, otherwise a chemical reaction will occur, resulting in serious deformation of the wiper blade.

Automatic wiper

Front wiper

Front wiper position

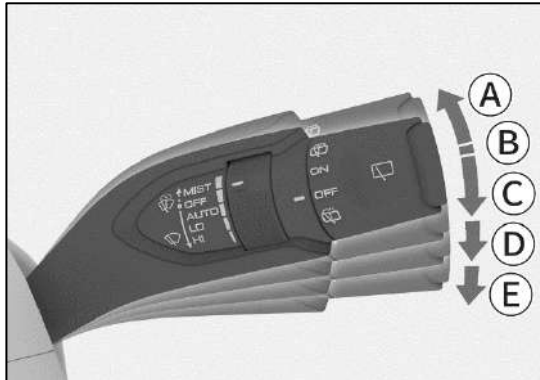

275CCCA3323B

- (A) Front wiper mist operation (MIST)
Pull the wiper control combination switch upwards to the MIST position. Once released, the lever will automatically return to its original position. The front wipers will operate once.
- (B) Turn off front wiper (OFF)
- (C) Intermittent wipe (INT)
- (D) Low speed (LO)
- (E) High speed (HI)

⚠ CAUTION

- › If the windscreen is dirty or has any foreign object stuck to it (such as snow or tree sap and so on), please clean off and remove the foreign object before use to avoid damaging the blade and the internal structure of the wiper.
- › Before using the wipers in the cold season, you shall check whether the wiper blade is frozen to the windscreen. If the wiper blades are frozen to the windscreen, make sure to defrost them before use to avoid damaging the blade and wiper motor.

- › If the wiper get stuck for any reasons, such as snow, please turn off the wiper and park the vehicle at a safe location as soon as possible. Then remove anything that is preventing the wipers from wiping so that the wiper can work normally.

Adjustment of auto wiping frequency



4C411A8EFC4D

- › Turn the rotation adjustment knob to change the sensitivity settings for the rainfall and light sensor in order to adjust the wiping frequency of the front wiper at the auto wiping position.

⚠ WARNING

- › The rainfall and light sensor is unable to recognize all precipitation to activate the front wiper. If rain on the windscreen affects the line of sight, you shall manually adjust the front wiper gear or wiper frequency timely as required.
- › When the automatic front wiper is in the AUTO position, the front wiper may operate unexpectedly if it touches the windscreen near the inside rearview mirror from outside the vehicle or the windscreen glass is vibrated. Be careful not to grip your fingers or other parts by the front wiper.
- › Do not place the automatic front wiper in the AUTO position when you wash the car or no front wiper is required to be used. Otherwise, the front wiper may operate unexpectedly.

⚠ CAUTION

- › If the windscreen near the interior rearview mirror is dirty or has any foreign object stuck to it (such as snow or tree sap and so on), please clean off and remove the foreign object before use to avoid damaging the blade and the internal structure of the wiper.
- › Even if snowflakes come in contact with the rainfall and light sensor, the sensor may not operate normally and the front wipers may not function, as snowflakes come in different shapes. The snow melted may cause the front wiper to automatically brush.

Washing function

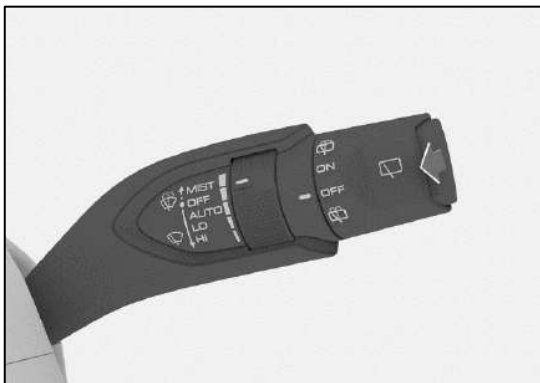

930465496923

Pull up and hold the wiper control combination switch towards the steering wheel, then the front wipers will use windscreen washer fluid to wipe the front windscreen. When released, the combination switch will return automatically.

⚠ CAUTION

- › Avoid using the washer for a long time. Otherwise it may damage the washing motor. To protect the washing motor, the washer may automatically shut down after a period of continuous operation.
- › When the washer fluid is insufficient, please replenish it. In cold seasons, appropriate washer fluid shall be added to ensure that the washer fluid does not freeze. Otherwise, the washer will not only lose the washing function, but also freeze the relevant parts.

- › When the washer fluid is insufficient, please replenish it. In cold seasons, appropriate washer fluid shall be added to ensure that the washer fluid does not freeze. Otherwise, the washer will not only lose the washing function, but also freeze the relevant parts.
- › Do not use the product which can produce cladding on the windscreen (for example, the screen wash contains plated crystal or coating film, glass coating and so on). Otherwise, the wiper may bounce and make abnormal sounds when wiping.
- › The blade cannot get contact with oily cleaning agent. They may react chemically which cause the blade deformed.

Rear wiper



2603A334FC8A

- › Turn the rear wiper control knob to the ON position and the rear wiper will turn on.
- › Turn the rear wiper control knob to the rear windscreen cleaning position  and hold. The rear wiper will wipe the rear windscreen using screen washer. Release the control knob and it will return automatically to its previous position.
- › Turn the rear wiper control knob to the OFF position to turn off the rear wiper.



⚠ CAUTION

- › Do not use the product which can produce cladding on the windscreen (for example, the screenwash contains plated crystal or coating film, glass coating and so on). Otherwise, the wiper may bounce and make abnormal sounds when wiping.
- › The blade cannot get contact with oily cleaning agent. They may react chemically which cause the blade deformed.

Front wiper and washer settings

The interval from the time when the washer function is activated to the time when the front wiper starts to wipe can be set via [Vehicle Settings]→ [In-Car] → [Body]→[Front Working Interval] /[Front wiper interval] on the multimedia display screen.

Air conditioning system

Vehicle equipment

Please note that this manual contains all the standard equipment, country-specific equipment and special equipment for this model series. Thus, some equipment or features described in this manual may not be installed onto your vehicle or are only available in some markets. For further configuration information, please refer to relevant sales information or consult with your distributor selling the vehicle to you.

Air conditioning control panel



Button control type



2D0D9945C5A5

- › Press ON/OFF to turn on or turn off the air-conditioning system.
- › Press A/C button to activate or deactivate the cooling mode. The corresponding indicator illuminates, indicating that the cooling mode is activated. In this mode, the inside temperature and humidity may be reduced.
- › Press the internal circulation button  to switch between the internal circulation and external circulation modes.
The corresponding indicator lights up, indicating that the internal circulation mode has been turned on.
The corresponding indicator is extinguished, indicating that the external circulation mode has been turned on. In this case, the air outside the vehicle can be introduced into the vehicle.

i NOTICE

- › Normally, you should put the system in external circulation mode. Use of internal circulation mode tends to cause foggy windows, especially when the compressor is turned off.
- › The internal circulation mode should be used under various circumstances such as driving inside a tunnel or in the traffic jam, dirty air outside the vehicle or quick cooling and heating is desired.
- › Press the front defroster button  to enable/disable the front defroster function. The corresponding indicator lights up, suggesting that the front defroster function has been enabled, and the frosting and fogging of the front windshield and the side door glass can be gradually eliminated.
- › Press the rear window defroster button  to enable/disable the rear window defroster function. The corresponding indicator lights up, indicating that the rear window defroster has been turned on. At this time, you can gradually relieve the frosting of the rear window.
The rear window defrosting function will turn off automatically after it has been turned on for a period of time, and the corresponding indicator will go out.

⚠ WARNING

Once the rear window defrosting function has been enabled, the rear windshield will become hot. Do not touch it to avoid burns.

⚠ CAUTION

When the vehicle is not started, please do not use the rear window defrosting function for a long time, so as to prevent the battery power from being drained.

Touch control type



233A31854529

- › Tap ON/OFF to turn on or turn off the air conditioning system.
- › Tap A/C button to activate or deactivate the cooling mode. The corresponding indicator illuminates, indicating that the cooling mode is activated. In this mode, the inside temperature and humidity may be reduced.
- › Tap the internal circulation button  to switch between the internal circulation and external circulation modes. The corresponding indicator lights up, indicating that the internal circulation mode has been turned on. The corresponding indicator is extinguished, indicating that the external circulation mode has been turned on. In this case, the air outside the vehicle can be introduced into the vehicle.

i NOTICE

- › Normally, you should put the system in external circulation mode. Use of internal circulation mode tends to cause foggy windows, especially when the compressor is turned off.

- › The internal circulation mode should be used under various circumstances such as driving inside tunnel or in the traffic jam, dirty air outside the vehicle or quick cooling and heating is desired.

- › Touch the front defroster button  to enable/disable the front defroster function. The corresponding indicator lights up, suggesting that the front defroster function has been enabled, and the frosting and fogging of the front windshield and the side door glass can be gradually eliminated.

- › Touch the rear window defroster  button to enable/disable the rear window defroster function. The corresponding indicator lights up, indicating that the rear window defroster has been turned on. At this time, you can gradually relieve the frosting of the rear window.

The rear window defrosting function will turn off automatically after it has been turned on for a period of time, and the corresponding indicator will go out.

⚠ WARNING

Once the rear window defrosting function has been enabled, the rear windshield will become hot. Do not touch it to avoid burns.

⚠ CAUTION

When the vehicle is not started, please do not use the rear window defrosting function for a long time, so as to prevent the battery power from being drained.

A/C setting interface

i NOTICE

- › The multimedia display interface and its operation may vary with the model configurations. Refer to the actual vehicle.
- › The air conditioning system consumes the power battery when it is working, reducing the driving range.
- › Under extreme operating conditions (e.g. high or low ambient temperatures, longtime slope climbing, etc.), the air conditioning may be limited in its power or even stop working in order to ensure the vehicle power performance.

Type I





98744953B64F

Type II



A35D9205BE9E







- › Touch the internal circulation button  or the external circulation button to make the A/C system switch between the internal and external circulation modes.
- › The internal circulation indicator light  goes on, indicating that the internal circulation mode has been turned on.
- › The external circulation indicator light goes on, indicating that the external circulation mode has been turned on. In this case, the air outside the vehicle can be introduced into the vehicle.

NOTICE

- › Normally, the external circulation mode should be used. Using the internal circulation mode tends to cause windows to fog, especially when the compressor is turned off.
- › The internal circulation mode should be used under such circumstances as the tunnel, traffic jam, dirty air outside the vehicle or quick cooling and heating desired.
- › Touch the A/C button to enable or disable the cooling mode. The corresponding indicator light turns on, indicating that the cooling mode is activated. In this mode, the interior temperature and humidity may be reduced.
- › Touch the AUTO button to activate the automatic mode. In this mode, the airflow distribution mode and the airflow can be automatically adjusted to reach the set temperature.

NOTICE

If you are not satisfied with the automatic adjustments, you can manually make adjustments. In this case, the automatic mode will exit and the indicator light will be off.



- › Touch the OFF button  to turn off the air conditioning system.
Touch the OFF button to turn off the air conditioning system.
- › Touch the face-blowing mode button  the feet and face-blowing mode button  the feet-blowing mode button  or the feet-blowing and defroster mode button  to select the corresponding airflow distribution mode.
- › Touch or slide the temperature display area on the air conditioning setting interface to adjust the temperature.
- › Touch the rear defroster button  to activate or deactivate the rear defroster function. The corresponding indicator light goes on, indicating that the rear defroster function has been enabled. In this case, the frosting of the rear windscreen can be gradually eliminated. The rear defroster function will automatically switch off after a period of time and the corresponding indicator light will go out.





WARNING

Once the rear defroster function is on, the rear windscreen will become hot. Do not touch it, and take care to avoid getting burnt.

CAUTION

When the vehicle is not started, do not use the rear defroster function for a long time, so as to prevent the undervoltage battery.

- › Touch the front defroster button  to activate or deactivate the front defroster function. The corresponding indicator light goes on, indicating that the front defroster function has been enabled. In this case, the frosting and fogging of the front windscreen and the side door glass can be gradually eliminated.
- › Touch the air flow  button to show the air flow adjustment panel. The air flow can be adjusted by touching or sliding at the area on the air flow adjustment panel.

- › Touch the synchronization  or disconnect  button to enable or disable the zone control mode. When the synchronization indicator light  goes on, the zone control mode has been turned off. In this case, the front passenger side air conditioning temperature remains the same as the driver side air conditioning temperature. Also, when the driver side air conditioning temperature is adjusted, the front passenger side air conditioning temperature is adjusted simultaneously.
- › When the disconnect indicator light  goes on, the zone control mode has been turned on. In this case, when the driver side air conditioning temperature is adjusted, the front passenger side air conditioning temperature is not affected. When the front passenger side air conditioning temperature is adjusted, the zone control mode is automatically turned on.
- › Touch the more A/C settings button  to show more air conditioning settings interface.

A/C setting

On the A/C setting interface, tap the  button to pop up the A/C function setting interface.

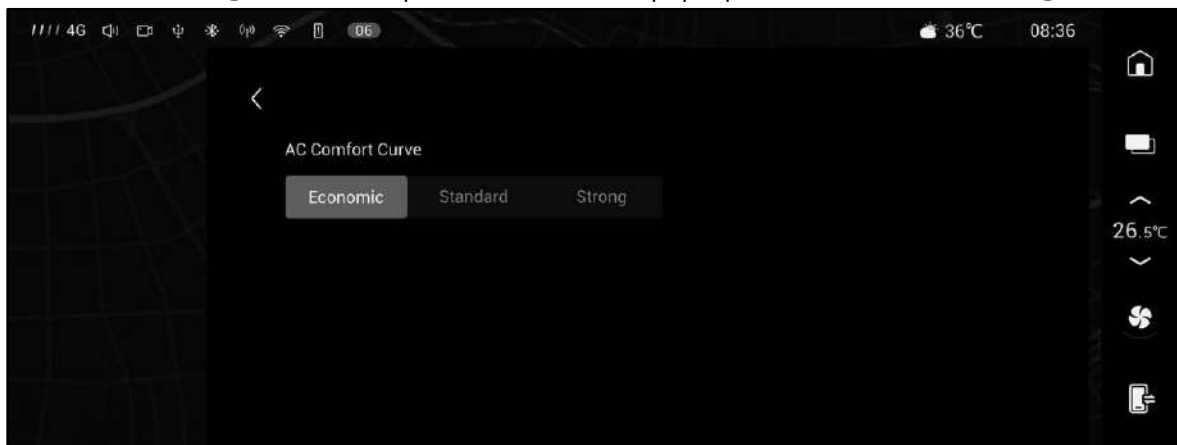

3943CBB07AC1

[A/C comfort curve] : set the comfort effect of the A/C system in AUTO mode.

- › Economy: the cooling or heating effect of the A/C system is softer with smaller air volume compared with the standard mode.
- › Standard: the A/C system automatically controls the outlet temperature and air volume according to the temperature set by the user.
- › Powerful: the cooling or heating effect of the A/C system is stronger with larger air volume compared with the standard mode.

Air conditioning control

Cooling/heating

After starting the vehicle:

1. Select the [**AUTO**] mode and the corresponding indicator light will turn on. At this moment, the compressor will automatically turn on or off depending on the temperature and the environment.
2. Set the temperature to your desired value. The A/C system will automatically adjust the air distribution mode and the airflow to achieve the set temperature.
3. Selecting the internal circulation mode may speed up cooling or heating and help to improve the economy and comfort of the vehicle.

i NOTICE

- › When the vehicle is exposed to the burning sun for a long time, the temperature in the vehicle will be very high. In this case, if you need to drive the vehicle, you are recommended to lower all the windows for ventilation and then enable the air conditioning cooling mode. After the heat in the vehicle is dissipated, raise all the windows.
- › After the air conditioning temperature is set, the air conditioning system will automatically control the working state of the cooling system and the heating system according to the interior and exterior ambient temperature.

After the air conditioning system is turned on in the cold season, the heating system needs to warm up for a period of time before it can work normally. Before the heating system finishes the warming up, the air conditioning system may not distribute warm air, and its airflow is small. This is normal.

Front defroster/front defogger

After starting the vehicle :

1. Select the front defroster mode, and the corresponding indicator light will turn on.

2. You can also adjust the airflow or the temperature, turn on or off the compressor, or switch between the internal and external circulation modes on demand.

i NOTICE

It is recommended to switch to the external circulation mode if interior air is heavily polluted or the interior is fogged up.

⚠ CAUTION

- › Check the radiator and the air conditioning condenser on a regular basis. Use a low-pressure water gun or a soft brush to remove the leaves, insects and dust from their front surfaces. Otherwise, these objects will block the air flow, thereby reducing the cooling effect.
- › Running the air conditioning regularly keeps the compressor and seals well lubricated and prevents leakage. Therefore, even in the cold season when air conditioning is not required, it is necessary to run the air conditioning at least once a week for more than 10 minutes each time.
- › If the A/C system does not cool as well as before, head to the authorised service centre for maintenance.
- › Direct discharge of refrigerant into the atmosphere is harmful to the environment and the refrigerant should be recovered by the trained and certified technicians using appropriate containers.

i NOTICE

About the air conditioning odour

› Source of odour

Internal and external air exchange should be carried out for air conditioning as its long-term use may gather dirt which will go mouldy after a long time, resulting in odour.

The air conditioning filter will accumulate water vapour, dust, etc. after use for a long time, resulting in odour.

› Suggestions

When the outside air is fresh, the external circulation mode is recommended for use to keep the interior air circulating.

When the vehicle is in cooling mode, you are recommended to turn off the [A/C] switch first and let the air conditioning continue running for about 3 to 5 minutes before turning off the air conditioning system. This will dry off the air conditioning evaporator and the air conditioning system to prevent mould growth and reduce odours.

When you smell a foul odour, you are recommended to head to the authorized service centre for check. Clean or replace the air conditioning filter element, if necessary.

A/C Vent

Front vents



C29A0AC0685A

By turning the slats at the center of the vent, adjust the direction of air flow.

Slide the slats as indicated by the left-to-close marking ☒ ← or right-to-close marking → ☒ to the limit position to close the air vent.

Rear vent



2D16855FBB72

By turning the slats at the center of the vent, adjust the direction of air flow.

Slide the slats as indicated by the left-to-close marking ☒ ← or right-to-close marking → ☒ to the limit position to close the air vent.

Mobile phone wireless charging

Vehicle equipment

Please note that this manual contains all the standard equipment, country-specific equipment and special equipment for this model series. Thus, some equipment or features described in this manual may not be installed onto your vehicle or are only available in some markets. For further configuration information, please refer to relevant sales information or consult with your distributor selling the vehicle to you.

Instruction

The wireless charging function can be turned on or turned off via [Vehicle Settings]→[In-Car]→[Wireless Charger] on the multimedia display screen.

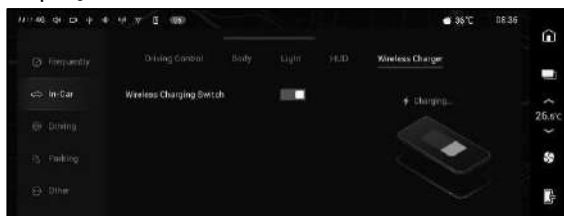

DOAADCF605A7

After turning on the wireless charging function of mobile phone, make sure that the doors are closed, switch to the power supply mode ON or start the vehicle. Then the mobile phone placed in the charging area can be charged.



6CAFE4E5E636

i NOTICE

In order to achieve a better charging effect, ensure that the charging coil of the mobile phone is facing downwards.

- › After turning on the wireless charging reminding function of mobile phone, a voice prompt can be issued when the charging status changes.

i NOTICE

- › This function is not applicable to all mobile phones, but only to mobile phones that have passed the "Qi" official standard certification and can be normally placed in the charging area.
- › Only one mobile phone can be charged at a time.
- › On bumpy roads, intermittent stopping and resuming of wireless charging may occur. If the mobile phone deviates from the charging area and the charging stops, move the mobile phone back to the chargeable area.
- › It is normal that wireless charging devices and mobile phones will get hot during charging. When the temperature is too high, the system will stop charging, and will continue charging after the temperature drops.
- › If the mobile phone is faulty, this may also cause it to fail to be charged. Other mobile phones that meet the requirements can be used for wireless charging detection to confirm whether the mobile phone is faulty.
- › If the mobile phone is equipped with a protective cover or an accessory that does not support wireless charging, it should be removed first; otherwise, the phone cannot be charged normally.
- › To prevent the undervoltage battery, do not use the wireless charging function for a long time when the vehicle is not started.



⚠ WARNING

- › For the sake of safety, drivers should not perform charging related operations during driving.
- › Do not place coins, keys, chip cards and other metal objects in the charging area. Otherwise, metal objects may be heated, which may lead to abnormal charging or safety accidents. If metal foreign objects are found in the charging area during charging, do not remove them by hand to avoid scalding your fingers. You should turn off the wireless charging function immediately, and wait a few minutes before removing foreign objects.
- › If you need to use the charging area as a storage case, turn off the wireless charging function.

⚠ CAUTION

- › Do not spray any liquid at the charging area, so as to avoid the liquid seeping into the wireless charging system through the clearance of rubber mat, which may lead to system failure.
- › Do not modify the wireless charging system to avoid damage to the vehicle or accidents.

i NOTICE

This device conforms to standards or technical requirements of NBTC.

Interior equipment

Vehicle equipment

Please note that this manual contains all the standard equipment, country-specific equipment and special equipment for this model series. Thus, some equipment or features described in this manual may not be installed onto your vehicle or are only available in some markets. For further configuration information, please refer to relevant sales information or consult with your distributor selling the vehicle to you.

Sun visor

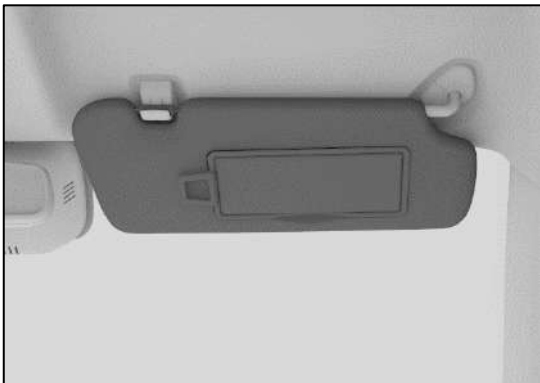

38F95C98BECD

To block sunlight from straight ahead, flip down the sun visor.

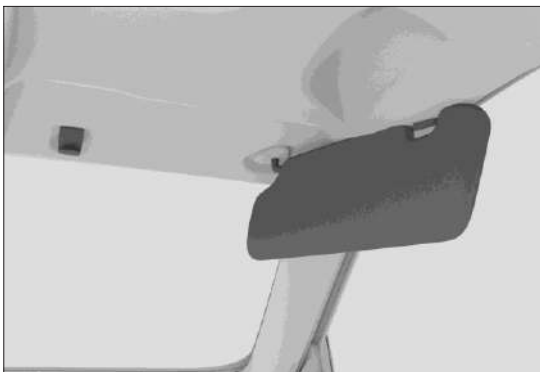

EE7A67445D9C

To block sunlight coming in from the side, flip down the sun visor, unhook it and push it to the side.

Vanity mirror

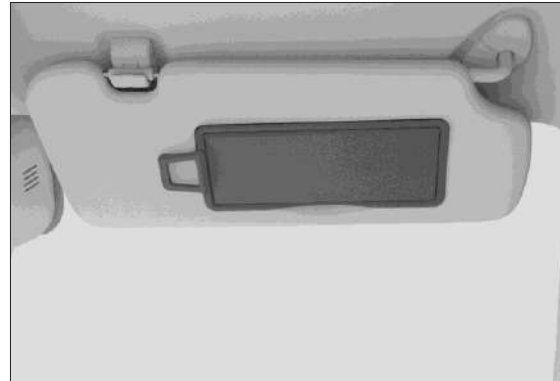

51777FC8915A

A vanity mirror is set inside the sun visor. Open the cover and use it.

Please close the lid when not using the vanity mirror.

Storage box



1912CCA13F51

Pull the handle on the storage box and flip down to open it.

Flip the storage box up until the lock is in place and then close it.

⚠ WARNING

Make sure the storage box is closed when driving. Otherwise, such items may be dislodged from the storage box and lead to an injury in the case of an accident or emergency braking.

Storage case



O2FA26A0FFDD

Pull up the open handle on the storage case and flip up to open it.

Spectacle case



O2E02E3D9CF9

Press the spectacle case to open it.
When placing glasses, fold the two mirror legs normally, with the lens facing forward and the mirror leg facing upward.
Otherwise, the glasses may fall off when opening the glasses case.

⚠ WARNING

Make sure the spectacle case has been closed when driving.

i NOTICE

Certain oversized sunglasses models may not fit into this case.

Front cup holder



58DA9A649F90

Press and release the front cup holder cover. Open the cup holder cover slightly to use the cup holder.

⚠ CAUTION

- > Don't place small or unstable beverage cans in the cup holders, or they may tip over.
- > Make sure that the lid of the beverage can is covered to avoid spilling liquid.

Rear cup holders

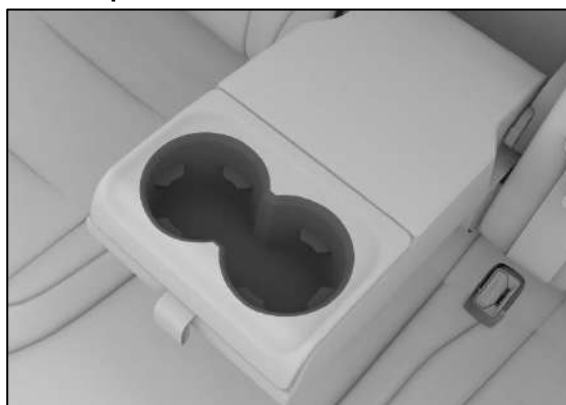

4F3CB3866BC8

Tilt the rear seat armrests to the lowest position to use.

⚠ CAUTION

- > Don't place small or unstable beverage cans in the cup holders, or they may tip over.
- > Make sure that the lid of the beverage can is covered to avoid spilling liquid.

Bottle holder

There is a bottle holder on the inside of each front door, which is only used for placing the sealed bottle container.

⚠ WARNING

Do not place anything other than bottles inside the bottle holder. Otherwise, in the case of an accident or emergency braking, such items may be dislodged from the bottle holder and lead to an injury.

⚠ CAUTION

Make sure that the lid of the bottle is covered to avoid spilling liquid.

Power supply socket

USB power supply socket



AAC251107CED

It is located beside the rear air conditioning outlet. When the power supply mode is in ON mode, just open the cover to use it.

This power supply can be used to charge the devices such as mobile phones and tablets.

Standby power supply

i NOTICE

Due to different vehicle configurations, standby power supply of some models may be installed in the hollow place on the left side of the auxiliary instrument panel. Please refer to the actual vehicle.

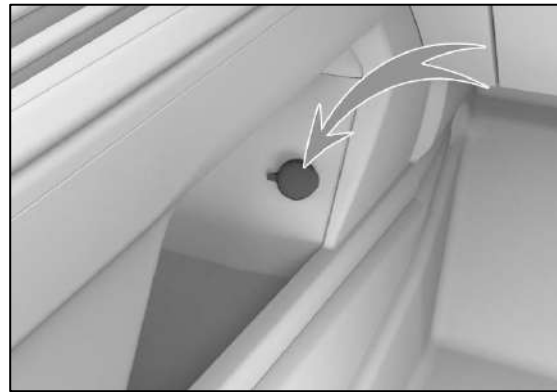

A45CFE3BD469

When the power supply mode is in ON mode, just open the cover to use it.

This power supply can provide a 12 V DC power for accessories with rated power less than or equal to 120 W (10 A).

Driving recorder power supply



C7102FC3177F

It is located near the interior rearview mirror.

The power supply can be used when the power supply mode is in the ON mode.

This power supply is designed to provide a 5 V DC power supply for driving recorders whose rated power is less than or equal to 10 W.

⚠ WARNING

- > For driving safety, be careful not to block the line of sight to prevent danger when installing a driving recorder.
- > Flammable gases and heaters must be kept away from the power supply socket.



⚠ CAUTION

- › Do not allow liquids such as beverages or foreign objects to enter the power supply socket. Otherwise, the faults like short circuits may be caused. If the power supply socket has a cover, close the cover when it is not in use.
- › If you use an accessory that exceeds the rated power, the vehicle fuse may be burnt out.
- › Do not connect precision devices, highly sensitive equipment or other important equipment to this power supply socket.
- › Do not use this power supply in humid and high-temperature environments.
- › Never use it in parallel or in series with any other power supply.
- › If you find any abnormal condition (e.g. unusually high temperatures, smoke, odors, etc.) during use, please stop using immediately and contact the authorized service centre for inspection and repair.
- › Modifying or repairing this power supply system without authorization is forbidden.
- › The external wiring harness should be waterproof and sealed.

Driving procedures.....	64
Advice on driving in harsh environments.....	68
Advice on driving during run-in.....	72
Hybrid vehicles.....	73
Power supply mode.....	76
Starting and shutting down vehicle.....	77
Parking brake.....	79
Automatic transmission.....	81
Driving mode.....	84
Single pedal function.....	85
Vehicle wash/trailer mode.....	87
Fording mode.....	88
Steering wheel assist mode.....	89
Parking assist system.....	91
Tyre pressure monitoring system.....	98
Fatigue driving reminder system.....	99
Cruise control system.....	100
Cruise control assist system.....	102
Intelligent driving assist system.....	107
Hill descent control system.....	117
Driving assist system.....	118
Emission control system.....	120
Head-up display (HUD).....	122
Virtual instrument.....	123
Indicator lights on the instrument.....	128
Power supply management system.....	134

Vehicle equipment

Please note that this manual contains all the standard equipment, country-specific equipment and special equipment for this model series. Thus, some equipment or features described in this manual may not be installed onto your vehicle or are only available in some markets. For further configuration information, please refer to relevant sales information or consult with your distributor selling the vehicle to you.

Before driving

Removing miscellaneous items

Remove the snow and fallen leaves, etc. accumulated on the vehicle before driving.

Check vehicle conditions

Please check daily items such as tyres, fluid, light and body appearance before driving in order to ensure you have a safe and pleasant driving experience.

If you believe that your vehicle requires maintenance or repair, please get in touch with your authorised service centre in a timely manner.

Confirm that the vehicle doors and the engine hood are closed

Before driving, make sure all vehicle doors are closed. If a vehicle door has not been closed properly, it may open unexpectedly during the driving and cause an accident.

Before driving, if you have opened up the engine hood, check that the hood has been locked down. If the engine hood has not been secured and locked properly, it may fly open during driving and cause an accident.

Placing objects within the vehicle

On the instrument panel

Do not place any item on the instrument panel as the items placed on the instrument panel may

not only obstructs the driver's view, but also affect the starting and safe driving, which may lead to an accident.

The driver's feet space

Do not place any item at the feet of the driver. Items placed at the driver's feet may be trapped under pedals, causing the driver to lose control of the vehicle, or leading to an accident.

If you want to use a floor mat, please choose an appropriate floor mat. If the selected floor mat shape and its layout position are inappropriate or if floor mats are double stacked, brake pedal performance may be affected. As a result, the vehicle may not be started, it's difficult or unable to change gears or even lead to a higher risk of other accidents.

Under the seat

Do not place any item under the seats. Items placed under the seat will make it difficult to adjust the seat position or lock the seat in place, which could easily lead to an accident.

Seat backrest

Do not place cushions and other items between the seat backrest and the back of the human body as it might affect the driving posture. Besides, in the event of a vehicle collision, the effectiveness of seat belts and head restraints will not be realized to the full, which may result in serious life-threatening injuries.

On the window glass

Do not attach items such as decorative items using vacuum suction cups on vehicle windows. Vacuum suction cups can act as a lens, leading to a higher risk of fires.

Precautions for driving

Driving over the speed limit is prohibited.

The vehicle shall not exceed the speed indicated by speed limit signs or mark lines.

Overloading the vehicle is prohibited

Overloaded driving is dangerous. Do not carry passengers or goods more than what is on the indicated maximum limit. Do not carry passengers in the luggage area or the trunk.

Fatigue driving is prohibited

Fatigue driving is extremely dangerous as the judgement, view and attention of driver in fatigue state will drop substantially. It is likely to bring about severe accident.

Shutting down the vehicle is prohibited

The brake assist device and power steering system will not work if the vehicle is shut down while driving, which may lead to deterioration of braking efficiency, and cause severe accident.

Turning the steering wheel fully in either direction and holding it there for an extended period of time is prohibited

Failure to do so may make the power steering system have less efficiency, or even damage the system.

Braking

While driving, do not continuously step on the brake pedal or apply the parking brake. Failure to adhere to the advice may lead to premature wear-and-tear in the brake pad or overheating in the brakes, thereby affecting braking efficiency and possibly leading to accidents as a result.

The brake emits a warning sound

The disc brake will emit a warning sound when the brake pad wears and needs to be replaced. If you hear a seismic noise while braking, do not continue driving. Otherwise it will severely wear the brake disk, damage the brake parts and affect the braking efficiency or even lead to an accident.

Flat tyre

It is forbidden to continue to drive the vehicle under the flat tyre condition. Driving with one or more flat tyres is extremely dangerous since it heightens the probability of accidents. In addition, tyres, wheels, suspension and vehicle body will be damaged. At this moment, please replace the tyre immediately.

When any of the following situations occur, check if vehicle tyres are punctured or have gone flat.

- > When the steering wheel vibrates.
- > When the vehicle vibrates abnormally.
- > When the vehicle is leaning at an abnormal angle.

If a tyre is flat or broken during driving, hold the steering wheel firmly and gently step on the brake pedal to slow down.

Emergency braking or sudden steering may lead the vehicle to go out of control.

The vehicle's undercarriage, tyres, and wheels suffer a strong impact

When the vehicle's undercarriage, tyres, and wheels suffer a strong impact, stop the vehicle immediately in a safe spot and inspect the vehicle. Check that there is no leaking of brake fluid or fuel, and that suspension parts, tyres, wheels, drive shaft components, etc., are not deformed or damaged. If you discover signs of leakage or damage, do not continue to drive the vehicle. Failure to adhere to the advice may lead to accidents.

When going downhill

Vehicle shutdown or neutral coasting is prohibited

The braking force assist device and power steering system will not work if the vehicle is shut down while driving downslope. In this scenario, braking efficiency will be compromised and you feel the steering wheel heavy, making the occurrence of accidents more likely.

Driving on uneven road surfaces

When stopping on a curb or on a road surface with a height difference, make sure that the tyre is not crushed and deformed by the curb or other obstacles.

When the vehicle must pass a curb, a deceleration zone or a similar obstacle, you should try to slow down along the vertical angle of the obstacle. Failure to do so may result in damage to the tyre, especially to the side wall of the tyre.

Driving in the following road conditions may cause damage to the bumper. Please slow down and drive carefully.

- › Where there are varying levels, such as at parking lot entry/exit points.
- › Where there are steep slopes, like in the case of multi-story parking lots.
- › Uneven road and road section with track.
- › Sections of road where there are potholes.
- › When moving from a flat surface onto a slope, or when moving from a slope
- › onto a flat surface.
- › When parking on road with deceleration strip or along curb.

Driving on slippery road surfaces, such as wet, snow-covered, or icy roads

Emergency braking, sudden acceleration, or sudden steering on slippery road surfaces may cause vehicle tyres to skid and the vehicle to go out of control, thereby causing an accident.

When accelerating and decelerating, the engine speed may make a significant change, it is prone to occurring side slip and thus causing an accident.

In cold weather, you should slow down when driving in areas of ice, such as bridges and shady areas.

Driving on flooded roads

Be careful while driving on a flooded road. Driving on a flooded road may lead to short circuit of electrical components or damage to

electrical elements, resulting in a major accident.

While driving on a flooded road, the brake pads will become wet and braking efficiency will be reduced, which can easily lead to accidents. Please step gently and repeatedly on the brake pedal in order to warm up the brake until full brake performance has been recovered.

Precautions for passengers

Moving within the vehicle is forbidden

It is forbidden for the passenger to leave his or her seat, or to move around inside the vehicle. Otherwise, during emergency braking, the passenger's body or head, etc., may suffer injurious impact.

Do not extend your hands or head outside the vehicle window or sunroof

If you stretch your hands or head out of the vehicle, it is prone to hitting against the window frame when braking the vehicle in emergency or closing the window. In this case, it may cause serious injury or even death.

Do not carry child passengers on your lap

When riding as a passenger, do not carry infant or child passengers on your lap even if you are already wearing a seat belt. Further, do not surround or enclose the infant or child using any part of the seat belt; this may cause grievous injury or even death during collisions or emergency braking.

Child passengers must not be allowed to operate equipment such as vehicle doors, vehicle windows and the sunroof

If child passengers are allowed to operate doors, windows and sunroof, they are at risk of clipping their hands, heads, necks, etc., in the

operation. All these can cause grievous hurt. If the vehicle door is opened during the driving, it is prone to shooting the children out of the vehicle and consequently, causing serious injuries and even death. Please use a child safety lock and a window lock switch to prevent children from accidents because of an incorrect operation.

Parking the vehicle

Do not park near flammable materials

Do not drive or stop on a road with a lot of flammable materials such as grass or scrap paper. Wood or plywood placed too close behind the vehicle may cause a fire.

Do not run the vehicle for a long time in poorly ventilated places

Do not run the vehicle for a long time in a poorly ventilated area such as a garage. This may cause exhaust gas to accumulate, which may lead to carbon monoxide poisoning, causing serious personal injury and even death.

Economic driving

Predictable driving

Maintain a proper distance with the front running vehicle and avoid unnecessary acceleration and braking. The stable vehicle speed can increase the driving range.

Avoid unnecessary weight

The loaded and overloaded driving of the vehicle will increase energy consumption. Before driving, remove unnecessary items from the vehicle.

Check tyre pressure periodically

Too small tyre pressure will increase the rolling resistance, thereby increasing the energy consumption while increasing tyre wear.

Regular maintenance

Regular maintenance ensures a longer service life and the best economy of your vehicle.

Turn off temporarily unnecessary electrical components

Turn off temporarily unnecessary functions such as the air-conditioning, seat heating and rear window heating to reduce power use.

Close windows and sunroof

Opening the windows or the sunroof increases drag, so turn them off when you do not need them.

Inertial glide

The accelerator pedal should be released when approaching the red light or on a larger slope, allowing the vehicle to take advantage of inertial glide.

Advice on driving in harsh environments

Vehicle equipment

Please note that this manual contains all the standard equipment, country-specific equipment and special equipment for this model series. Thus, some equipment or features described in this manual may not be installed onto your vehicle or are only available in some markets. For further configuration information, please refer to relevant sales information or consult with your distributor selling the vehicle to you.

Driving in foggy weather

Turn on the fog lamps

While driving in fog, you should turn on the fog lamps.

Sound horn to warn pedestrians and vehicles

If you hear the horn of other vehicles, respond immediately by honking your horn to indicate your position.

Drive at low speed and look out for safety

When driving in foggy weather, try to travel at a low speed and keep a safe distance from the vehicle ahead.

Do not wipe fog on the glass during vehicle running

Due to large temperature difference inside and outside the cab, mist may condensates on the inside surface of the windscreen that can affect driver's sight.

In this case, you can use the A/C defrosting function or open the vehicle windows a little to have the same air temperature inside and outside the vehicle.

This will prevent condensation to form on the inside surface of windscreen. If you wish to wipe away the condensation on the windscreen glass, please do so only after bringing the vehicle to a stop. Never try to do so while driving the vehicle.

Driving in the rain

Please drive carefully on slippery road surfaces

As poor vision, foggy windscreen and slippery roads are likely to occur when running on rainy days, please drive carefully.

When performing emergency braking, steering and accelerating on a slippery road, tyres may slip, making it difficult to control the vehicle, which may lead to an accident.

While driving in rain, water film can form between the tyre and the ground. At this time the tyre can easily lose its grip, so for safe driving you should slow down.

WARNING

Try to avoid driving in a heavy rain or a rainstorm.
Try to avoid driving in a heavy rain or a rainstorm

Wading drive

Precautions for wading drive

- > Before wading drive, you shall confirm the water depth of the road area. If there is more water or the water depth is unknown, you shall drive to take a detour and not go through a direct course.
- > By analyzing road conditions, do not allow the vehicle to enter an unknown region. Such regions may contain hidden obstacles, such as ditches or manholes.
- > While fording in the water, keep low speed (speed should not exceed 10 km/h) and do not park or shift gears.
- > When the vehicle passes an intersection, try to avoid the waves generated by the preceding vehicle to prevent water from entering the front grille.
- > During fording in the water, if the vehicle can not move due to power failure (flameout) caused by a malfunction, do not try to start the vehicle again at this point. Immediately consult authorized service centre for treatment.

Check and maintenance after Wading

Once the vehicle has been safely driven through water, perform the following operations immediately:

- › Step on the brake pedal a few times consecutively, and check whether brake performance has been compromised.
- › Check the horn.
- › Check all vehicle lights.
- › head to the authorised service centre as soon as possible for routine inspection. During wading drive, water may enter the components and parts of transmission system and dilute lubricant, which may lead to system malfunctions.

CAUTION

- › Travel in water is only applicable in emergency situations and it cannot be used as a part of routine driving.
- › Driving through water can damage the engine and electrical components.

Driving during the hot seasons

Hot weather and high temperature in summer are bad for the normal vehicle running and the health of driver. To ensure driving safety, the driver shall pay attention to the following items:

To prevent the engine from overheating

The engine is prone to overheating in the hot season due to higher ambient temperature. Therefore, please step up the inspection and maintenance of the engine cooling system, and remove debris embedded in the radiator chips.

Preventing flat tyre

As air pressure in the vehicle tyre rises with temperature increase, flat tyre is likely to occur in case of hot weather and high temperature in hot season.

If you experience a flat tyre in the course of the drive, hold the steering wheel securely, step gently on the brake pedal to decelerate, and avoid actions such as emergency braking or sudden steering. Failure to adhere to the advice may cause the vehicle to go out of control.

Preventing sunstroke

Strong sunlight and high temperature in hot season easily lead to sunstroke. Keep the driving room well ventilated and prohibit fatigue driving.

WARNING

Never leave a child in the vehicle unattended.

- › Leaving children alone in the vehicle during hot seasons can easily cause heat stroke, dehydration, personal injury or even death.
- › If the child, left alone in the vehicle, plays with matches, lighters other items, it is easy to cause vehicle fire accidents.

CAUTION

When parking the vehicle, do not leave items such as lighters, spray can, soft drink cans, spectacles, etc. inside the vehicle.

- › As temperatures inside the vehicle can get very high, a leakage of gas from the lighter, spray cans or cracks in these containers can lead to fire.
- › Should a soft drink can burst inside the vehicle, its contents may splash onto electrical components and cause short circuit.
- › As temperatures inside the vehicle can get very high, it is easy to make resin lens or glasses deformation, resulting in crack.

Driving in cold season

Snow tyre

In the cold season when the temperature is low, due to the special characteristics of the standard tyre (tyre width, rubber composition and pattern type, etc.), the tyre elasticity

decreases, further weakening the traction and braking force. At the same time, the tyre noise will be increased, even leading to serious standard tyre cracks, abnormal wear and tear and other permanent damage.

It is recommended to use snow tyres when the temperature is lower than 7°C in cold season. Snow tyres can greatly improve the handling stability of the vehicle, but also improve the vehicle's braking response and shorten the braking distance.

i NOTICE

Although all-season tyres with M + S markings are better for the cold season, they fail to achieve the performance of snow tyres. Therefore, it is still necessary to use snow tyres when driving on snowy or icy roads.

⚠ WARNING

Although snow tyres can improve the vehicle driving performance in winter, do not drive at risk situation, and still keep cautious!

- › **Be sure to adjust your speed and driving style based on visibility, weather conditions, road and traffic conditions.**
- › **Do not exceed the speed and load rating indicated on the installed snow tyres when driving.**

⚠ CAUTION

When the pattern of snow tyres is severely worn, their applicability to cold season will be largely lost. If snow tyres have aged, their applicability to cold season will largely be lost even though the tyre pattern wear is insignificant.

Consult the dealer for specific replacement standards of snow tyres.

Snow tyre instructions:

- › You must comply with the relevant laws and regulations of the host country.

- › The four wheels must have snow tyres installed at the same time.
- › Always use snow tyres having the same size as the standard tyre.
- › The same model, size (rolling circumference) and pattern type of snow tyres must be used.
- › Snow tyres can only be used during the cold season.
- › Be sure to comply with the allowable maximum limits for snow tyres (such as maximum speed, maximum load, etc.). Otherwise, tyres may be damaged, causing traffic accidents.
- › Do not reverse the rotation direction of the tyre.

Tyre chains

The use of tyre chains depends on the current standards in specific countries or regions, and the installation of tyre chains must comply with local regulations. Install tyre chains on the drive wheels only.

Do not install tyre chains on only one tyre. Install tyre chains following the instructions provided by the tyre chain manufacturer and tighten them as tightly as possible.

⚠ CAUTION

Observe the following precautions when installing tyre chains:

- › Improper size or installation of tyre chains will damage the vehicle brake pipeline, suspension, body and tyres, etc. Choose suitable tyre chains and ensure that they are properly installed.
- › Install and remove tyre chains in a safe location. Turn on the emergency flashers, and set the warning triangle behind the vehicle.
- › Always set the power supply to OFF mode and apply the parking brake before installing the tyre chains.
- › Do not install tyre chains on emergency wheels.

- › Do not install tyre chains when the tyre pressure is low.
- › Do not damage aluminium alloy wheel rim when using tyre chains.

⚠ WARNING

Observe the following precautions when driving with tyre chains:

- › After installing tyre chains, the driving speed shall not exceed 40 km/h or the max. speed recommended by the tyre chain manufacturer, whichever is lower
- › After installing tyre chains, always check that the tyre chains are properly installed after travelling 0.5 to 1.0 kilometer to ensure safety. Retighten or reinstall the tyre chains if they are loose.
- › After installing tyre chains, vehicle control may be adversely affected. Operation such as sudden acceleration, sharp turns and emergency braking should be avoided as much as possible, otherwise accidents may occur.
- › When driving, if you hear the tyre chain knocking on the vehicle body or chassis, stop the vehicle and re-tighten the tyre chain. If you can still hear the sound, slow down until the sound disappears.
- › Avoid driving on bumpy road surfaces or over potholes.
- › Slow down before entering the curve, so that you can control the vehicle.
- › Remove the tyre chains when driving on road surfaces without snow, or they may affect driving performance and severely damage tyre.

⚠ WARNING

When parking on snowy roads, shut down the vehicle powertrain.

- › If the engine is running at the start of the vehicle with snow accumulated around it, exhaust gas may seep inside the vehicle interior, causing severe injury or even death by carbon monoxide poisoning.
- › When you feel that exhaust gas comes into the vehicle, you can take the following measures:
- › Drive the vehicle to a ventilated area and open all the windows. Set the air conditioning to the external circulation mode, adjust the air flow to the maximum, and introduce fresh air from the outside into the vehicle.

Vehicle equipment

Please note that this manual contains all the standard equipment, country-specific equipment and special equipment for this model series. Thus, some equipment or features described in this manual may not be installed onto your vehicle or are only available in some markets. For further configuration information, please refer to relevant sales information or consult with your distributor selling the vehicle to you.

Tyre

Take extra care in the first 500 km when driving with a set of new tyres.

New tyres do not offer optimal grip until they have been broken-in.

Friction lining of brake pad

New friction lining of brake hardly achieves optimal braking effect within first 400 km vehicle running.

New friction lining of brake must also be run-in to achieve the best friction performance. If you feel that the braking force of the vehicle is insufficient, you can step on the brake pedal to increase the braking force.

During the run-in period, avoid applying extra load on the brake. For example, emergency braking, especially emergency braking at high speed and while running on slope.

CAUTION

- > The friction linings and brake disk may wear to different degrees depending on the using condition and the driving method.
- > Due to the vehicle speed, braking force and environmental conditions (such as temperature and humidity), there may be noise when braking, which is normal.

Hybrid vehicles

About hybrid vehicle

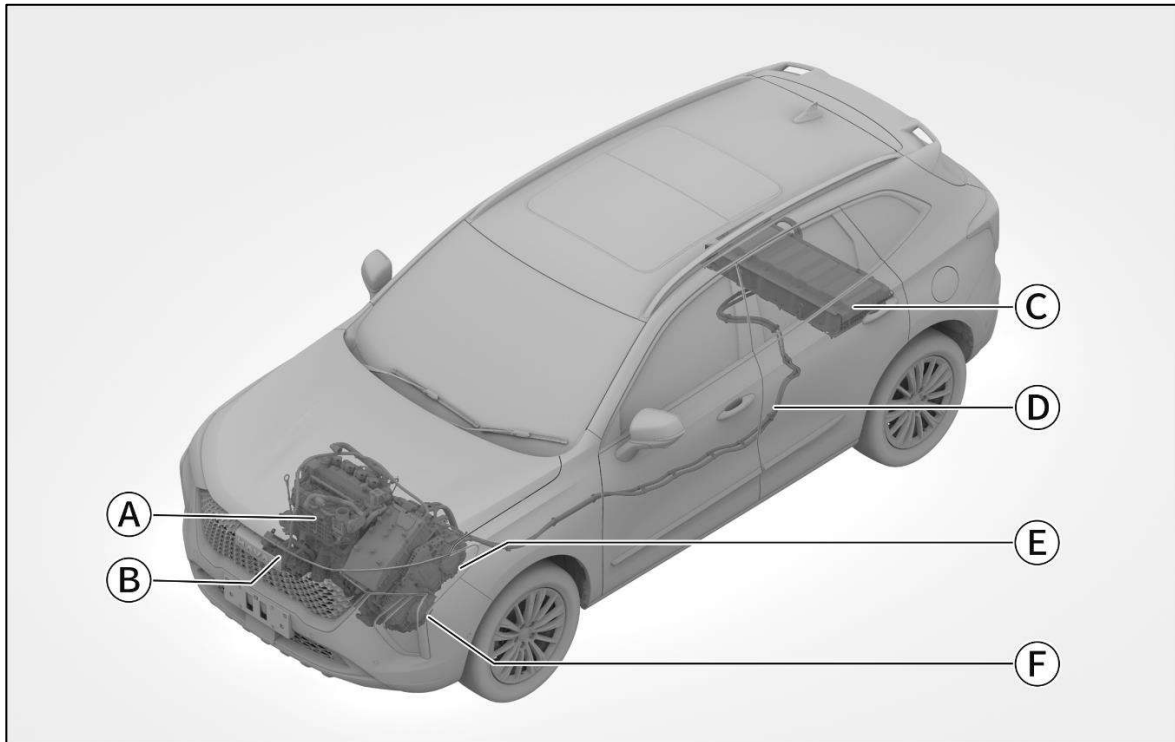

CF490C012FA6

- | | |
|------------------------|---------------------------------|
| (A) Gasoline engine | (D) High-voltage wiring harness |
| (B) A/C compressor | (E) Drive motor assembly |
| (C) Power battery pack | (F) Generator assembly |

i NOTICE

Depending on vehicle configuration, your vehicle may differ from the appearance shown in the figure. Please refer to the actual vehicle.

This vehicle is a hybrid vehicle, which is different from general fuel vehicles in characteristics. Please be familiar with the characteristics of the hybrid vehicle and drive it carefully.

⚠ WARNING

- › Do not touch, remove or replace parts with high-voltage warning signs, orange cable and their connectors on the vehicle to prevent high-voltage electric shock.
- › After the vehicle is started, the power system will be hot. Be careful of high voltage and high temperature, and always follow the instructions on the vehicle safety warning label.

The driving method of hybrid vehicles is exactly the same as that of general fuel vehicles. The hybrid power system can automatically start the operation mode of the engine and drive motor according to the running state and driving mode of the vehicle, thus improving fuel efficiency and reducing exhaust emission.

- › The drive motor usually drives the vehicle at a low speed.
- › The engine generally drives the vehicle at high speed or during more active driving.

Energy recovery

The function is mainly used to convert a part of kinetic energy of the vehicle during braking or coasting into electric energy of the power battery, thereby extending the distance to empty.

The energy recovery intensity can be set via [Vehicle Settings]→[In-Car]→[Driving Control]→[Energy Recovery Level] on the multimedia display screen.

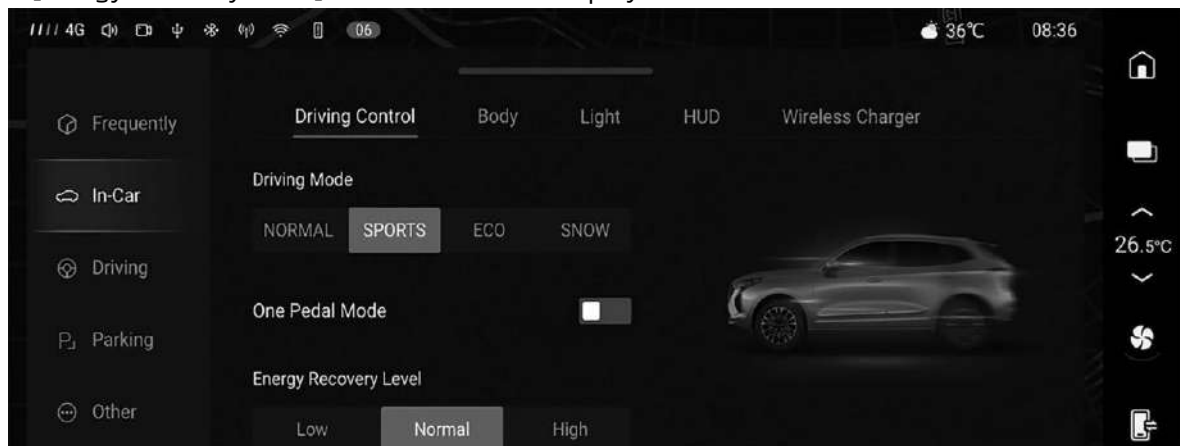

2B39B89D1E4F

i NOTICE

When the single pedal driving mode is started, the energy recovery intensity is not adjustable.

⚠ WARNING

The reduction of vehicle speed caused by energy recovery cannot be a substitute for normal braking. The brake pedal should be depressed during deceleration and parking.

i NOTICE

When the vehicle decelerates obviously as the energy recovery function is activated, the brake lamp may be turned on.

i NOTICE

The energy recovery will not be carried out when the vehicle is under the following conditions:

- › The vehicle is in N gear position.
- › The power battery is fully charged.
- › The temperature of the power battery is too high or too low.

Power battery vent

There is an air intake vent under the rear seat for cooling the power battery.

If the air inlet is blocked after the vehicle is started, the power battery will overheat.

To protect the power battery, the system may limit the discharge/charging of the power battery.

i NOTICE

- › Clean the vent regularly to prevent the power battery from overheating.
- › Do not place foreign matters near the vent; otherwise, the power battery may overheat and be damaged.
- › Prevent foreign matters or water from entering the vent; otherwise, a short circuit may occur and the power battery may be damaged.

Battery safety switch

The battery safety switch is used to disconnect or connect the power supply of the high voltage system.

⚠ WARNING

Do not attempt to operate the battery safety switch. It can be used only when repairing the vehicle and performing operations related to high voltage system.

Position 1 : near the fuse box of the engine compartment



26D3328BB5DA

Position 2 : under the luggage area

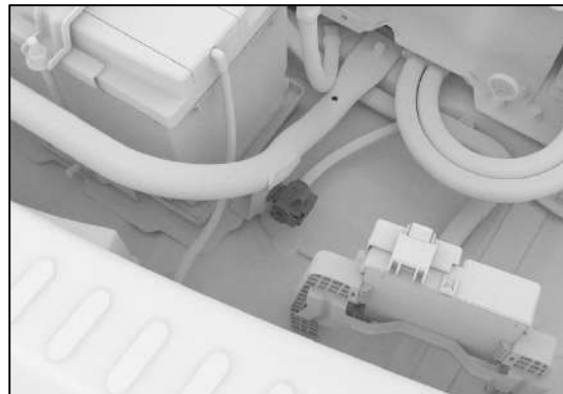

271AE9E2658B

Remove the fuse box cover and you can see it.

Power supply mode

Vehicle equipment

Please note that this manual contains all the standard equipment, country-specific equipment and special equipment for this model series. Thus, some equipment or features described in this manual may not be installed onto your vehicle or are only available in some markets. For further configuration information, please refer to relevant sales information or consult with your distributor selling the vehicle to you.

Power supply mode switching

When carrying the smart key, directly press the power supply switch to change the power supply mode.



60A8F42B7CAE

No.	Mode	Effect
1	OFF	Electrical components are in the nonworking state.
2	ON	All electrical components can be used.

i NOTICE

When the smart key is carried in the vehicle, depress the brake pedal with the shift lever in the P position. The vehicle can be started by pressing the power supply switch regardless of the power supply mode.

⚠ WARNING

Do not switch the power supply to OFF mode while driving.

⚠ CAUTION

- › Do not place the smart key on the instrument panel, on the ground, on the instrument cluster, in the storage box or in the luggage area. Otherwise, the power supply mode cannot be switched.
- › When the engine is not running, do not keep the power supply in the ON mode for an extended period of time to prevent loss of battery power.
- › When you leave the vehicle, switch the power supply to OFF mode and carry the key with you.

Starting and shutting down vehicle

Vehicle equipment

Please note that this manual contains all the standard equipment, country-specific equipment and special equipment for this model series. Thus, some equipment or features described in this manual may not be installed onto your vehicle or are only available in some markets. For further configuration information, please refer to relevant sales information or consult with your distributor selling the vehicle to you.

Starting the vehicle

Normal starting

1. Carry your smart key with you.
2. Adjust the seat position and take correct driving gesture.
3. Ensure that the parking brake is applied.
4. Make sure the P gear is engaged.
5. Depress the brake pedal.
6. Press the power supply switch to start the vehicle. (At this time, the indicator light READY in the instrument cluster being on indicates that the drive system is ready.)

i NOTICE

After the vehicle is started, the engine will start or stop automatically according to the vehicle state.

Try not to store the vehicle in a very cold environment, as this may cause the vehicle to fail to start.

Emergency start

If the prompt "Is the key in the vehicle" is shown (such as the under-voltage smart key, serious damage to the door guard or the rear bumper and other situations), place the key above the sign  in the bottom of the cup holder and perform the vehicle-on operations to start the vehicle. If the vehicle cannot be started, contact authorized service centre immediately.



6F9BB49E4883

When the smart key is lost, put the mechanical key above the marked position  on the bottom of the cup holder and perform the vehicle-on operations to start the vehicle. If the vehicle cannot be started, contact authorised service centre immediately.



D7578B674662

⚠ WARNING

- > Be sure to sit on the driver seat before starting the vehicle. Failure to do so may lead to accident, serious injury or even death.
- > Never step on the accelerator pedal under any circumstances when starting the vehicle.
- > Always start the vehicle even if you need to move the vehicle slightly. Otherwise, an accident may be caused.

Shutting down the vehicle

1. Stop the vehicle steadily and switch the shift lever to the gear P.
2. Press the power supply switch to shut down the vehicle.

Emergency shutdown

In case of emergencies such as inability to stop the vehicle by normal means during driving (at the speed of greater than 5 km/h), you can shut down the vehicle in emergency by performing any of the following operations:

- › Press and hold the power supply switch.
- › Press the power supply switch 3 times continuously within 2 seconds.

WARNING

- › Shutting down the vehicle while driving may cause a collision or major personal injury.
- › Do not forcibly shut down the vehicle while driving in non-emergency situations. When the vehicle is forcibly shut down, the brake and steering wheel power will be lost. As a result, it is more laborious to step on the brake pedal and the steering wheel is heavier. Therefore, decelerate as much as possible before shutting down the vehicle.

WARNING

Do not touch high-temperature components such as the engine, exhaust pipe, and radiator immediately after shutting down the engine. Otherwise, you may be burned.

NOTICE

After the engine has operated at a high speed or with high load for a long time, it is recommended to allow the engine to idle for a short time or drive at a low speed for some distance.

Parking braking

Vehicle equipment

Please note that this manual contains all the standard equipment, country-specific equipment and special equipment for this model series. Thus, some equipment or features described in this manual may not be installed onto your vehicle or are only available in some markets. For further configuration information, please refer to relevant sales information or consult with your distributor selling the vehicle to you.

Tips for safety

WARNING

- › Parking on a slope steeper than the prescribed limit may cause an accident. Please drive safely and avoid risk parking situations.
- › If the slope is too steep, use of the parking brake system will not be able to stop your vehicle completely. In this case, step on the brake pedal to prevent the vehicle from rolling.

Electronic parking brake (EPB)

Applying the parking brake



B189679B6768

- › When the vehicle is stationary and the power supply is switched to OFF mode, the electronic parking brake (EPB) will be applied automatically. At this point, the parking brake indicator light (P) on the instrument cluster turns on.

- › If the parking brake is not required, press and hold the EPB switch while switching the power supply to OFF mode.
- › After the vehicle is stationary, pull up the EPB switch to apply the parking brake. At this point, the parking brake indicator light (P) on the instrument cluster turns on.

Emergency braking

In case of emergency, pull up the EPB switch and hold it, and then use the EPB system to brake the vehicle.

Emergency braking can be cancelled as long as the EPB switch is released or the accelerator pedal is stepped on.

WARNING

The emergency braking function can only be used in the event of an emergency (e.g. the brake pedal is blocked).

Releasing the parking brake



7AAE367204E4

When the power supply is in ON mode, step on the brake pedal and press the EPB switch to release the parking brake.

At this time, the parking brake indicator light (P) on the instrument cluster turns off.

NOTICE

If the vehicle is powered off abnormally, the parking brake fault warning light (P) on the instrument cluster turns on after the vehicle

is powered on again. In this case, the system needs to self-learn. Pull up the EPB switch first, then depress the brake pedal and press the EPB switch to release the EPB normally.

AVH function



B918B72586DE

Auto Vehicle Hold (AVH) enable the driver not to step on the brake pedal for extended periods nor apply the electronic parking brake frequently when the vehicle is on a slope, meets red lights or stops and goes. It allows the driver to drive more comfortably and reduces the risk of vehicle rolling. After the driver door is closed, the driver seat belt is fastened, and the vehicle is started, press the AVH switch to turn on or off the automatic parking function.

Instructions

1. Turn on the AVH function. At this time, the automatic parking function is in the ready state, and the (A) indicator light on the instrument cluster turns yellow.
2. Depress the brake pedal to stop the vehicle. The vehicle will automatically apply the parking braking. At this point, the AVH function is working, and the indicator light (A) on the instrument cluster is green.

3. Step on the accelerator pedal and the parking brake is automatically released. If the accelerator pedal is not depressed for a long time, the AVH function will be deactivated, and the vehicle will automatically switch to electric parking mode, thus applying the braking force.

The following conditions will deactivate the AVH function forcedly:

- > The driver seat belt is released.
- > The driver door is opened.
- > Switch the power supply mode to OFF mode.
- > It works for more than 3 minutes.

⚠ CAUTION

In the case of automatic car washing and towing, the parking brake needs to be released. You can set wash/trailer mode via [Vehicle Settings]→[n-Car]→[Driving Control] on the multimedia display screen.

(▷ Page 87)

Automatic departure function

With the parking brake applied to the vehicle, the parking brake is automatically released when the driver fastens the seat belt, depresses the accelerator pedal and the system detects the driver's intention to depart.

On a slope, more traction is required to avoid rolling.

Automatic transmission

Vehicle equipment

Please note that this manual contains all the standard equipment, country-specific equipment and special equipment for this model series. Thus, some equipment or features described in this manual may not be installed onto your vehicle or are only available in some markets. For further configuration information, please refer to relevant sales information or consult with your distributor selling the vehicle to you.

Introduction to gear positions

Park gear (P)

The P gear is used to assist in parking the vehicle. When the P gear is engaged, the transmission is mechanically locked to prevent the vehicle from sliding.

i NOTICE

In case of abnormal power failure of the vehicle, the gear "P" will require self learning after the vehicle is powered on again. At this time, the system will perform self-learning automatically after the brake pedal is stepped on or the EPB is pulled up.

Revers (R) gear

The R gear is used for reversing.

Neutral (N)

The N gear is an unpowered gear, and the transmission system is in a state of not transmitting power when this gear is engaged. It is used when the vehicle is to be started or stopped.

⚠ WARNING

› When stopping the vehicle temporarily in gear N, be sure to apply parking brake or depress the brake pedal. Otherwise, the vehicle may coast and cause an accident.

› Vehicles are prohibited from coasting with the N gear engaged; otherwise, there is a risk of accidents.

Automatic mode (D)

The D gear is used for normal driving.

When the D gear is engaged, the transmission can automatically adjust till the appropriate position is reached based on the vehicle speed and the required acceleration, to achieve the best economy.

How to shift

After the vehicle is started, normal gear shifting operations can be performed. Before the start of the vehicle you should always step on the brake pedal; otherwise the vehicle will move if the driving gear of the shift lever has been engaged.

⚠ WARNING

In order to avoid the damage to the vehicle or accidents, the vehicle must be completely stopped before the gear is engaged.

i NOTICE

- › When the vehicle speed is lower than 2 km/h, and the driver's door is opened and the driver's seat belt is released, the vehicle will be shifted to gear P automatically.
- › After the vehicle is turned off, it will automatically switch to P gear.

i NOTICE

When the shift is completed, make sure that the correct gear is engaged.

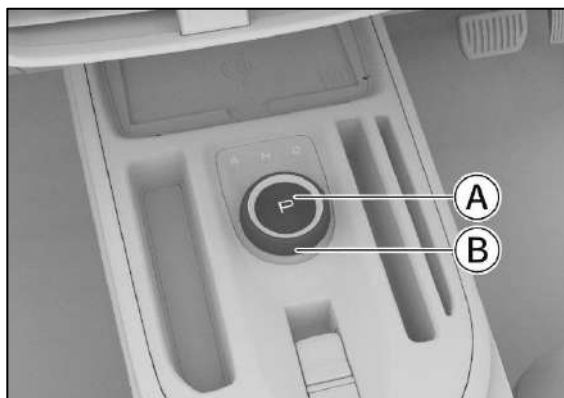

220B68470DD2

- (A) Parking gear button
- (B) Shift knob

Shift to P gear

When the vehicle is stationary, press the parking gear button.

Shift to gear D, R or N

- › When switching from P gear to N, R or D gear in case the vehicle is stationary, depress the brake pedal and turn the knob.
- › When switching from N gear to D gear in case the vehicle is stationary, depress the brake pedal and clockwise turn the knob.
- › When switching from N gear to R gear in case the vehicle is stationary, depress the brake pedal and counterclockwise turn the knob.
- › When switching from D gear to N gear, just counterclockwise turn the knob directly.
When switching from R gear to N gear, just clockwise turn the knob directly.

i NOTICE

The engaged gear will be shown on the shift panel and the multi-information display of the combination instrument.

⚠ WARNING

If a transmission-related error message appears on the combination instrument the transmission may enter the emergency operation mode.

At this point, you can only shift to a specific gear or simply cannot shift gears. Please stop at the safe place as soon as possible and contact authorised service centre.

Crawling function

After the vehicle is started, you shall switch to the driving position, and release the parking brake and the brake pedal. At this time, you don't need to step on the accelerator pedal, and the vehicle can crawl slowly.

Start the vehicle

How to move off normally

1. Fasten the seat belt and confirm that the parking brake has been applied.
2. Start the vehicle.
3. Depress the brake pedal and engage gear D.
4. Release the brake pedal and then gently step on the accelerator pedal to allow the vehicle to accelerate.

i NOTICE

When the vehicle starts, the automatic DDA function will automatically release the parking brake.

Launch Control

1. Fasten the seat belt and confirm that the parking brake has been applied.
2. Start the vehicle and confirm that the ESC function is turned off.
3. Left foot depress the brake pedal, put the gear in position "D", and release the parking brake.
4. When the accelerator pedal is depressed on your right foot, the instrument will prompt "launch control activated".
5. After the brake pedal is released, the vehicle starts to launch until the vehicle is started.

WARNING

- › Be sure to drive carefully within the limits permitted by law.
- › Launch control can only be used in places without cross traffic or pedestrians. The driver has the responsibility to ensure that the driving mode and acceleration do not endanger or hinder the safety of other traffic participants.
- › The function cannot be used when the vehicle runs on slippery roads. Otherwise, the vehicle will get out of control and cause an accident.

CAUTION

If the braking time is too long (about 8 seconds) and the vehicle does not start after the launch control mode is activated, the launch control function will be disabled and the timeout protection will be enabled to protect the motor system. When the vehicle is in timeout state, it is necessary to release accelerator pedal before disabling the timeout state for the next launch control.

NOTICE

When the power battery has a low power or temperature, the launch control function may not be available.

Stop the vehicle

1. After releasing the accelerator pedal, depress the brake pedal.
2. After the engine speed is stable, switch to the P gear.
3. Apply the parking brake or shut down the vehicle engine directly as required.

NOTICE

After the vehicle engine is shut down, the vehicle will automatically apply the parking brake.

4. Release the brake pedal.

CAUTION

- › When it is necessary to stop the vehicle temporarily at the slope, the brake pedal must be stepped on or the parking brake must be applied. Do not use accelerate pedal or crawling function to keep the vehicle stable, otherwise the transmission will be damaged.
- › Do not use the P gear to park on the slope, otherwise it will damage the transmission.
- › When stopping the vehicle on a slope, block the wheels with something if necessary to prevent rolling.

Driving mode

Vehicle equipment

Please note that this manual contains all the standard equipment, country-specific equipment and special equipment for this model series. Thus, some equipment or features described in this manual may not be installed onto your vehicle or are only available in some markets. For the further configuration information, please refer to relevant sales information or consult with your distributor selling the vehicle to you.

Switching method

The vehicle driving mode can be set in the NOR, ECO, SPORT or SNOW mode via the [Vehicle Settings]→[In-Car]→[Driving Control] on the multimedia display.

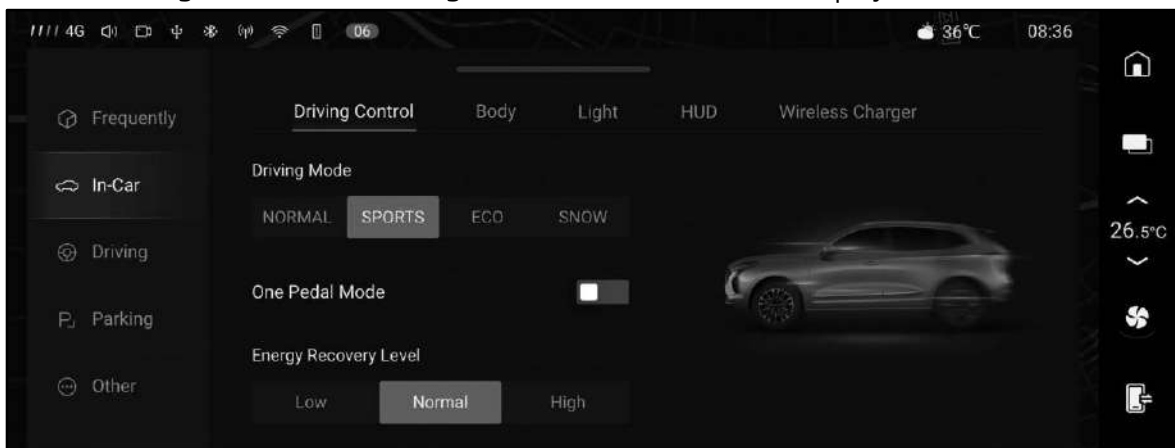

316296C03F18

Standard mode

The vehicle will choose the best driving mode according to the current driving condition and the dynamic property and economy of the vehicle.

Economic mode

It delivers optimal fuel economy, with fuel consumption reduction and comfort as the primary goal, and is suitable for medium- and low-speed road conditions.

Sport mode

Increase the vehicle power, resulting in a higher level of responsiveness and driving experience. Suitable for use on wide, flat roads with few vehicles.

i NOTICE

When the main lamp switch is in the AUTO position, the sport mode lighting setting can be activated or deactivated via the [Light Settings] on the multimedia display screen.

Snow mode

It is suitable for driving on snow, wet and low-adhesion roads, ensuring more stable and safe driving of vehicles under severe driving conditions.

Single pedal function

Vehicle equipment

Please note that this manual contains all the standard equipment, country-specific equipment and special equipment for this model series. Thus, some equipment or features described in this manual may not be installed onto your vehicle or are only available in some markets. For the further configuration information, please refer to relevant sales information or consult with your distributor selling the vehicle to you.

Single pedal mode

Turn on or turn off single pedal mode via multimedia by [Vehicle Settings] → [In-Car] → [Driving control]

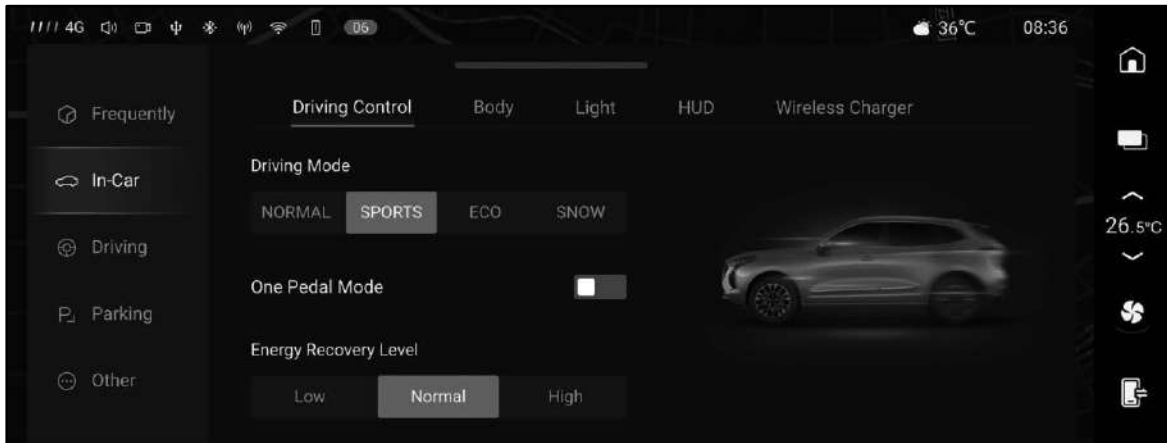

ECB595505773

How to use

When the single pedal driving function is turned on and the gear is in position "D", the accelerator pedal can be depressed, raised or completely released for accelerating, sliding, decelerating, and stopping completely. Meeting the normal driving requirements, it is operated flexibly and easily and can be used to improve the range significantly.

The following conditions may cause the single pedal driving function to be turned off or malfunction.

- › The driving is in snow mode.
- › The driving mode is switched to snow mode.
- › The accelerator pedal, brake pedal or the whole vehicle is faulty.
- › When the operation intervene the vehicle torque, such as AVH, cruise assist, Intelligent cruise, Intelligent drive and so on.

⚠ WARNING

- › The speed reduction caused by single pedal driving function cannot replace normal braking completely. In case of emergency, please step on the brake pedal in time.
- › It is not recommended to use the single pedal driving function under snow, ice or slippery road conditions.

⚠ CAUTION

When the gradient is too high or the vehicle is in trouble, please step on the brake pedal in time to prevent the vehicle from slipping.

The single pedal driving function allows the vehicle to slow down and stop by invoking energy recovery. A vehicle can stop on most paved roads, but the deceleration effect will be affected by slope gradient and vehicle load. Therefore, drivers shall always be prepared for braking.

i NOTICE

The electronic parking brake (EPB) will be automatically applied after 3 minutes when the vehicle is decelerated and stopped by using the single pedal driving function.

Vehicle wash/trailer mode

Vehicle equipment

Please note that this manual contains all the standard equipment, country-specific equipment and special equipment for this model series. Thus, some equipment or features described in this manual may not be installed onto your vehicle or are only available in some markets. For the further configuration information, please refer to relevant sales information or consult with your distributor selling the vehicle to you.

Vehicle wash/trailer mode

Turn on or turn off wash/trailer mode via [Vehicle Settings]→[In-Car]→[Driving] on the multimedia display screen. After the mode is turned on, the vehicle will automatically shift into gear N and release the parking brake.

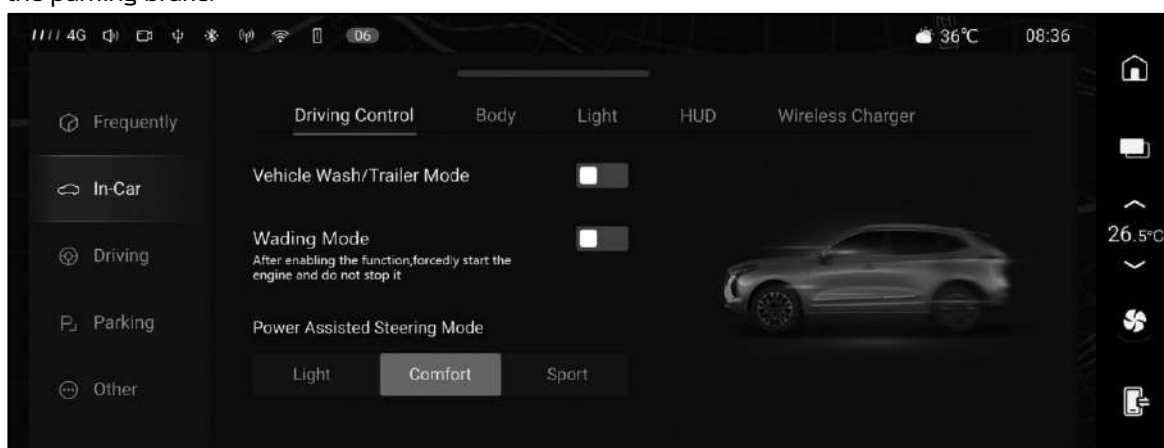

ADIBE1AD8494

This mode is used for washing the vehicle or towing the vehicle to a flat trailer, but it is not suitable for towing the vehicle for a long time.

Opening method

- › Engage the gear P.
- › Depress and hold the brake pedal.
- › Start the vehicle wash/trailer mode through multimedia.

i NOTICE

The vehicle wash/trailer mode will turn off automatically when the following conditions occur.

- › Switch the power supply to OFF mode.
- › Enable the parking brake function.
- › The vehicle speed is higher than 8 km/h.
- › The battery power is drained or the voltage is too low.

Fording mode

Vehicle equipment

Please note that this manual contains all the standard equipment, country-specific equipment and special equipment for this model series. Thus, some equipment or features described in this manual may not be installed onto your vehicle or are only available in some markets. For the further configuration information, please refer to relevant sales information or consult with your distributor selling the vehicle to you.

Wading mode

Before wading, turn on or turn off wash/trailer mode via multimedia by [Vehicle Settings] → [In-Car] → [Driving control] After the mode is started, the system will force the engine to start without shutdown.

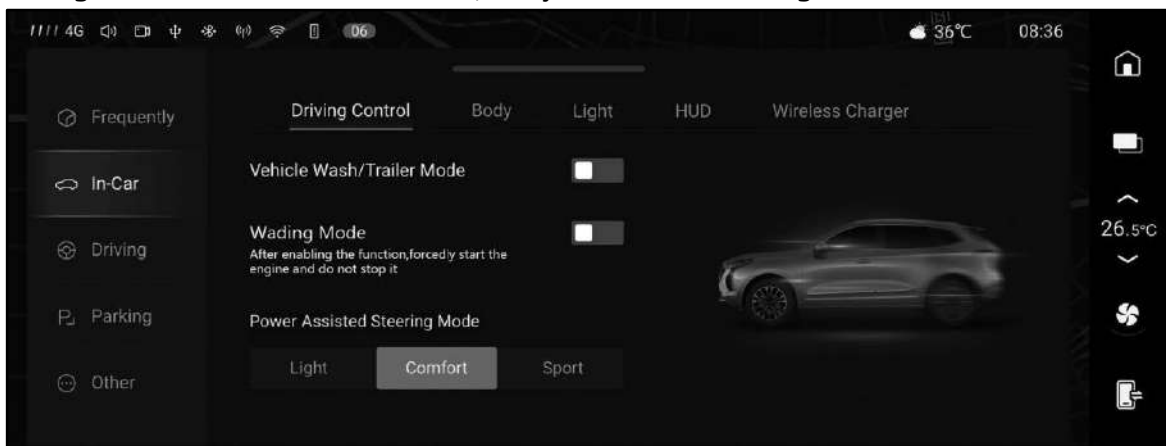

IDB38D3C093B

After wading, this mode can be turned off through multimedia.

i NOTICE

Wading is only applicable in emergency situations and cannot be used as a part of routine driving.

(▷ Page 68)

Steering wheel assist mode

Vehicle equipment

Please note that this manual contains all the standard equipment, country-specific equipment and special equipment for this model series. Thus, some equipment or features described in this manual may not be installed onto your vehicle or are only available in some markets. For the further configuration information, please refer to relevant sales information or consult with your distributor selling the vehicle to you.

Switching method

When the power supply is in ON mode, it can be switched to power steering mode via [Vehicle Settings] → [In-Car] → [Driving Control] on the multimedia display screen.

Type I

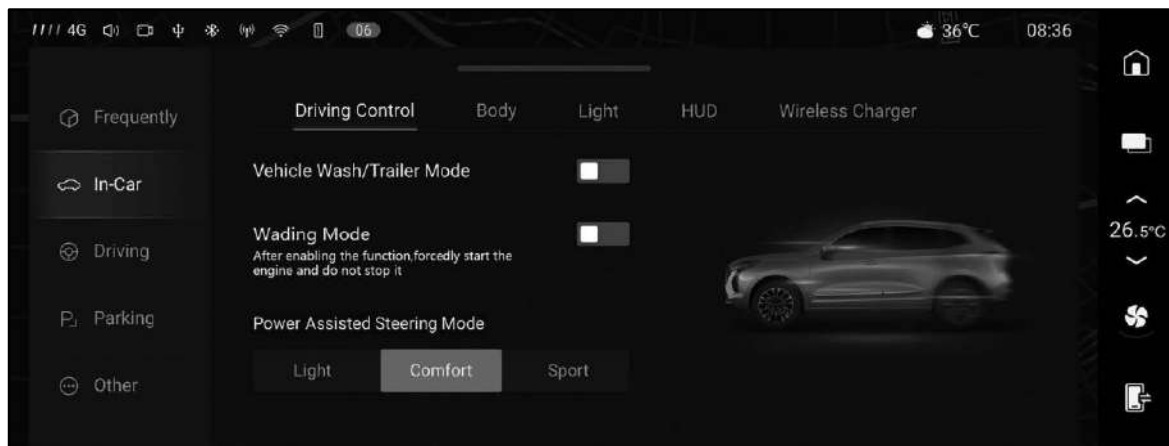

FE07865B853F

Type II

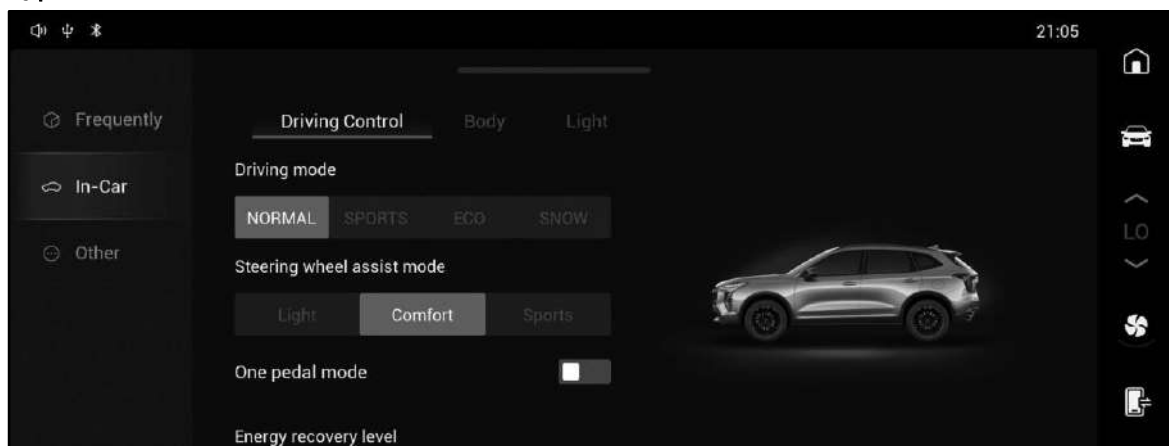

OA593A17E77C

i NOTICE

When switching between power steering modes, the following conditions need to be met:

- › The electric power steering system is functioning correctly.
- › The vehicle speed is less than 125 km/h.
- › No apparent turn operation has been carried out.



Light

It increases the power steering for easy steering. It is applicable to traffic congestion driving environment such as urban areas.

Comfort

It is suitable for general driving habits.

Sport

It reduces the power steering and increases the steering wheel feedback. It is recommended to use it under high speed, rain and snow and other cases.

⚠ CAUTION

After the battery of the vehicle is disconnected, to power on and start the vehicle again, you should initialize the angle of the electric power steering (EPS) system. Otherwise, certain EPS functions will be abnormal. Operation approach: Turn the steering wheel counterclockwise to the limit and hold for about 1 s, then turn it clockwise to the limit and hold for about 1 s, and finally turn the steering wheel to make the wheels return to center.

Parking assist system

Vehicle equipment

Please note that this manual contains all the standard equipment, country-specific equipment and special equipment for this model series. Thus, some equipment or features described in this manual may not be installed onto your vehicle or are only available in some markets. For further configuration information, please refer to relevant sales information or consult with your distributor selling the vehicle to you.

Safety tips

WARNING

- › The parking assist system is only an auxiliary tool, which cannot replace the driver's judgement on external conditions. In any case, the driver should be responsible for the safety of the vehicle and observe the surrounding conditions of the vehicle at any time during parking or similar operations.
- › There are blind spots to the coverage of the parking assist system, and obstacles in certain areas may not be detected. Therefore, during parking or similar operations, please make sure that there are no children or animals near the vehicle.

CAUTION

- › When reversing, make sure that the tailgate has been fully closed.
- › Do not tap the camera and sensor.
- › Do not flush the camera and sensor with a high-pressure water gun in the front. Otherwise, water may result in system failure or fire.
- › Do not use wearing or sharp material to clean the camera and sensor.

Please wipe with a soft cloth or wash with water (low water pressure) to clean the surface of camera and sensor.

NOTICE

The radar detection device of parking assist system is affected by ultrasonic characteristics. Incapability or poor detection may be caused under the following circumstances, which are not system failures:

- › The obstacle is a wire net, fence, post, rope, or other such thin objects.
- › The obstacle is an object whose surface does not reflect the detection signal or a person wearing such clothing.
- › The obstacle is snow, cotton or other substances of which the surface can easily absorb sound waves.
- › The obstacle is below the radar sensor.
- › The obstacle is an acute-angle reflector or cone shaped object, such as a right-angle square column and a fire hydrant box.
- › Driving through grass or over rough terrain.
- › Reversing on a ramp.
- › There are ultrasonic noises with the same frequency around, such as metal noise, high-pressure gas emission noise, or a car horn directed at the sensor.
- › The license plate is bent or tilted, or a large license plate decorative frame is installed.
- › A foreign object is stuck to the surface of the sensor, such as invisible vehicle cover. In order to ensure the normal operation of the system, the sensor must be kept clean and free of snow and ice.

Reverse radar

System introduction

The reverse radar is a radar-detection device. When reversing, the sensor installed will work to detect any obstacle that is present behind the vehicle, as well as the distance between the vehicle and that obstacle. The system will provide the driver with audio prompts to help the driver park as easily and safely as possible, and to avoid collisions.

How to use

- › Switch to gear R and the reverse radar will automatically turn on.
- › When the R gear is exited, the reverse radar will automatically turn off.

Detection scope and alarm mode

Sensor position	Detection scope [m]
Rear on both sides	0.6
Rear center	1.5

If the sensor detects an obstacle within the detection scope after the reverse radar is turned on, the alarm will start. When the distance between the vehicle and the obstacle reduces, the frequency of alarm sounds will gradually increase. When the distance between the obstacle and the vehicle is within about 0.3m, the alarm sound will be heard for a long time, and the vehicle shall not be reversed to avoid collision.

Anti-collision radar

System description

An anti-collision radar is a radar detection device. During parking, sensors are used to detect whether there are obstacles in front of and behind the vehicle, detect the distance of obstacles, and give sound prompt to assist the driver to park safely and easily.

Instructions



3EEA03D8B88D

- › When the power supply is set to the ON mode or the engine is started, touch the button to manually turn on or off the anti-collision radar.
- › Switch to the R gear position and the anti-collision radar will automatically turn on. Switch to the P gear position and the anti-collision radar will automatically turn off. If the driving speed exceeds 15 km/h, the anti-collision radar will automatically turn off.

Detection scope and alarm mode

Radar sensor position	Detection scope [m]
Front on both sides	0.6
Front centre	1.0
Rear on both sides	0.6
Rear centre	1.5

After the anti-collision radar is activated, if the sensor detects obstacles within the detection range, it will start to give an alarm.

As the distance between the vehicle and the obstacle decreases, the frequency of alarm sounds will gradually increase.

When the distance between the obstacle and the vehicle is within about 0.3 m, the alarm sound will be heard for a long time. In this case, the vehicle should not be reversed continuously to avoid a collision.

Reverse camera

About the system

The reverse camera captures images from behind the vehicle using the rear view camera and transmits the image signal to the screen for display, thereby assisting the driver to safely and easily park the vehicle.

How to use

- › Switch to gear R and reverse camera will automatically turn on. After the reverse camera system is turned on, you can select various view modes according to personal preference.
- › The reverse camera will be deactivated automatically when R gear is exited.

Static guide line

The static guide line indicates the straight guide path when you reverse the vehicle. If an obstacle enters the red line area of the guide line, it shall immediately stop reversing, otherwise a collision accident will occur.

Around View Monitor (AVM)

System description

AVM uses four cameras to capture images surrounding the vehicle and sends a video signal to the display screen for display. This helps the driver safely and easily drive to avoid accidents.

Instructions



3EEA03D8B88D

- › When the power supply is set to the ON mode or the engine is started, touch the button to turn on or off the AVM.
- › When the R gear position is engaged, the AVM will turn on automatically.
- › When the P gear position is engaged, the AVM will turn off automatically.

Camera interface



OD3F5E5576C0

- (A) Function setting area
- (B) Top view area
- (C) Image area
- (D) View sign

Function setting

 : view switching button

Touch the button to switch to the wide view; and touch the button again to exit the wide view.

 : guide line

Touch the button to set the guide line to be revealed or hidden. After setting the display mode, the guide line displays the body width, which can assist the driver in parking.

 : radar obstacle

Touch the button to set the radar obstacle to show or hide. After the setting is shown and when an obstacle is detected, a radar identification will be shown in the obstacle direction.

MOD : lateral moving object detection

You can activate or deactivate the lateral moving object detection function. After the function is activated, when moving pedestrians, bicycles, or vehicles are detected, the image interface will display an alarm message.

 : vehicle washing station mode

Touch the button to enable or disable the washing station mode. After the washing station mode is enabled, the tyre's forward track will be displayed, and the line width indicates the tyre width.

 : system setting

Touch the setting button to enter the system setting interface, on which the [Intelligent viewing angle switch] function can be activated or deactivated.

The button is highlighted, indicating that the function is activated. When the function is turned on: When the vehicle is in the D gear position, if the front radar detects an obstacle less than or equal to 1 m from the vehicle body, it will automatically switch to the front top image.

When the vehicle is in the R gear position, if the rear radar detects an obstacle less than or equal to 1 m from the vehicle body, it will automatically switch to the rear top image.

It will automatically switch to the previous image after the obstacle is removed.

View switching

View switching

When the D gear is engaged, the image interface automatically switches to the front view image; when the R gear is engaged, the image interface automatically switches to the rear view image.

Manual view switching

Touch the top view area, then the top view displays the multi-directional control buttons. Touch to select the button indicating each direction, then the image area will display the view image corresponding to this button.

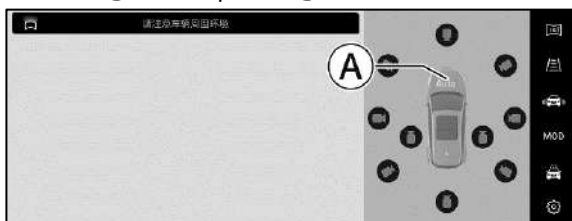

EAOA15CDE022

(A) Free view

After selecting the free view, drag the image area to adjust the view at will. When the vehicle speed exceeds 10 km/h, or the [AUTO] button on the top view is manually touched and selected, the system will switch to the automatic view mode.

CAUTION

If the doors (including the tailgate) are opened or the side mirrors are folded, the image on the corresponding side will not be shown properly.

Auto parking assist system

System introduction

The auto parking assist system identifies the proper parking space and automatically control the vehicle by sensors, and the driver can enter and exit a parking space by simply following the system prompts to maneuver the vehicle.

How to use



57AB5BDC0591

After starting the vehicle, the vehicle speed is less than 30 km/h, tap the button and the auto parking assist system is activated. Automatic parking is completed by following the prompts displayed on the multimedia display screen when the system is activated.

CAUTION

- › The fully automatic parking assist system can only be used in standard, economic or sports driving modes. In other driving modes, the fully automatic parking assist system is not available.
- › In order to ensure the parking safety, the driver needs to monitor the surrounding environment of the vehicle at any time, to brake and take over the vehicle in time when there is a collision risk.

NOTICE

- › The default parking mode can be set via the multimedia display screen.
- › The parking-out function can only be used when the vehicle is stationary.
- › When looking for the parking space, please make sure that the vehicle is 0.5 ~ 1.5 m away from the parking space nearby, otherwise, the full-automatic parking assist system may not identify the parking space.

Precautions

During automatic parking process, the following operations may cause temporary interruption of automatic parking. Automatic parking can be resumed when the interruption disappears.

- › Vehicle doors (including the back door) open.
- › Driver's seat belt unlocked.
- › Obstacles appear on the parking path.
- › Throttle intervention.

During automatic parking process, the following operations may cause automatic parking to exit.

- › The vehicle speed exceeds 40 km/h in the process of searching for parking space.
- › Gear, steering wheel or parking brake intervention.

- › Recoverable interruption beyond time limit, number of interruptions beyond limit, number of parking movements beyond limit, and total parking time. beyond time limit.
- › Press the  button.
- › When exiting from the parking space, if it judges that there is no travel direction or the road is clear, there is no need to use automatic parking function.
- › The slope of the ground where the vehicle is located is too large.

Cases in which automatic parking assist may not work properly:

- › There is irregular road edge near to the parking place or the road edge is covered by leaves and snow.
- › Parking space is located in corners or curves.
- › Heavy wear of the vehicle tyres or installation of unapproved tyres (including non-full-size spare tyres).
- › When parking over grass or rough terrain.
- › When the parking slot is forward/ reverse inclined position.
- › There are ultrasonic noises with the same frequency around, such as metal noise, high-pressure gas emission noise, and horn sensor buzzing.
- › The sensor is smudged or covered.
- › Heavy fog, rain or snow.

Cases in which automatic parking assist is forbidden:

- › Tyre chains or spare tyres are installed.
- › The loaded objects exceed the vehicle size.
- › A tow hook is installed.
- › The slope of the ground where the vehicle is located is too large.

Parking settings

The functions related to park setting system can be set via multimedia display screen, please refer to the actual vehicle for detail information.

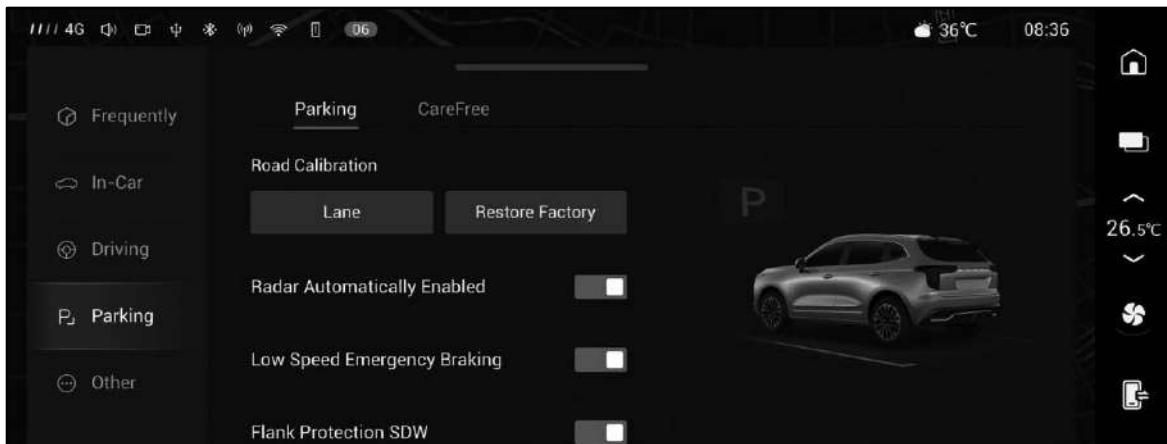

43C3A515080C

[Road calibration setting]

During the using of vehicle, when the camera position changes due to bumping of vehicles or aging of parts, the image mosaic may be misplaced, blurred and distorted.

At this time, the image mosaic effect can be optimized through the road calibration setting.

Please refer to the prompt information on the multimedia display screen for the specific calibration methods and requirements.

⚠ WARNING

Road calibration should be carried out in a well-lit and wide place. The road calibration process should strictly comply with road traffic.

[Setting of radar automatic starting]

You can turn on or turn off radar automatic activation function. After the function is enabled, if the moving speed is less than 10 km/h and there is an obstacle detected within the detection range, the front radar and image system will be started automatically. The system will be automatically turned off if with a few seconds the distance of the obstacle does not change, the obstacle is far away, or the vehicle is applying the parking brake.

[Flank protection]

After the function is enabled and when the sensors on the left and right sides of the vehicle identify obstacles, the system prompts the driver to park carefully through pictures and sound alarms.

[Low speed emergency braking]

You can turn on or turn off emergency braking function at low speed. After the function is activated, when the vehicle is running at a low speed, the low speed emergency braking indicator  on the image interface will be illuminated in green, which indicates that the function is normally activated. If an obstacle is detected during low speed driving and a collision risk is determined, the system will automatically apply emergency braking to reduce the risk of a collision. At this moment, the indicator turns red.

CAUTION

- > The function is only an auxiliary one, which cannot guarantee that all obstacles are detected under all conditions.
- > Under complex road conditions (such as off-road conditions or narrow passages), please turn off the low-speed emergency braking function. Otherwise, the system may apply unnecessary braking.
- > Please turn off the low-speed emergency braking function after the vehicle is equipped with traction devices or when the vehicle is towing other vehicles. Otherwise, the system may apply unnecessary braking.

[Default parking mode]

You can set the default parking mode of the auto parking assist system.

[Using vehicle at any time]

[Intelligent pre-cooling function]

You can activate or deactivate the intelligent view switch function. After starting the function, you can carry out pre-cooling function through mobile phone application, so that the vehicle can get proper temperature before using and improve user experience.

Tyre pressure monitoring system

Vehicle equipment

Please note that this manual contains all the standard equipment, country-specific equipment and special equipment for this model series. Thus, some equipment or features described in this manual may not be installed onto your vehicle or are only available in some markets. For further configuration information, please refer to relevant sales information or consult with your distributor selling the vehicle to you.

System introduction

The tyre pressure monitoring system (TPMS) monitors tyre pressure and temperature in real time and alerts the driver to take appropriate action to avoid an accident when an abnormality occurs in the tyre.

NOTICE





The communication device conforms to the standard and requirements of NBTC

CAUTION

- › If the tyre replaced is not a standard spare tyre, it may affect the normal operation of TPMS.
- › TPMS may not work properly when the tyre chain is installed or the wheel is covered.
- › TPMS may not work properly due to radio interference.
- › After replacement of tyres or tyre rotation, start the vehicle and drive at a speed higher than 30 km/h for about 9 minutes, then the TPMS will automatically identify the tyre pressure, tyre temperature and location. If the tyre pressure and the tyre temperature are not displayed or displayed incorrectly after 9 minutes, please contact authorized service centre to reset TPMS as soon as possible.

- › TPMS cannot replace regular tyre maintenance. Check the tyre frequently to ensure proper tyre pressure, even if no alarm is received from TPMS.
- › Tyre pressure can be affected by factors such as the heat generated from vehicle operations, the external environment, journey time, etc. Under normal conditions, the tyre pressure fluctuates around 30 kPa, which is normal.

Monitoring function

Press the Back button  on the steering wheel to switch the multi-information display to the driving data interface , and then press the Up button  or Down button  to switch the driving data interface to the tyre pressure monitoring interface so that you can view the pressure and temperature information of four in-use tyres in real time.

When the tyre pressure is too low or the temperature is too high, the abnormal tyre icon on the tyre pressure monitoring interface shows red and flashes.

Alarm function

When the tyre pressure is too low or the temperature is too high, the combination instrument will send out the following alarm as follows:

- › The multi-information display will display the corresponding alarm interface. The abnormal tyre icon is displayed as red and sends out audible alarm.
- › Tyre pressure monitoring system warning lamp  on the combination instrument illuminates.

If the tyre alarm message appears in the trip, you should avoid performing sudden, acute turns and emergency braking. Reduce the speed, drive to a safe area and stop the vehicle as soon as possible. Then contact authorised service centre for trouble handling.

Fatigue driving reminder system

Vehicle equipment

Please note that this manual contains all the standard equipment, country-specific equipment and special equipment for this model series. Thus, some equipment or features described in this manual may not be installed onto your vehicle or are only available in some markets. For further configuration information, please refer to relevant sales information or consult with your distributor selling the vehicle to you.

Introduction of fatigue driving reminder

The fatigue driving reminder system identifies the driver's fatigue level by continuously detecting the driver's operation of the vehicle. If the system recognizes that driver is fatigue, sound and visual alarms will be given to alert the driver to drive with care.

WARNING

- › Fatigue driving is strictly prohibited. Reasonable parking intervals should always be arranged for long-distance driving to ensure adequate rest.
- › It is always the driver's responsibility to ensure that he/she is in a good driving condition.
- › Fatigue driving warning function is only an auxiliary tool and may not be able to actually monitor driver fatigue. In some cases, the system may judge normal driving behavior as fatigue.

Instructions

The fatigue driving reminder function can be activated or deactivated via [Vehicle Settings] → [In-Car] → [Body] on the multimedia display screen. The [Fatigue driving reminder] function is activated by default.

Fatigue warning

When the system monitors the following conditions, the instrument cluster displays a "Reminder: Take a Break" alarm screen, accompanied by an audible alarm.

- › The system detects that the driver is in a fatigue driving condition and the vehicle speed exceeds 65 km/h.
- › The vehicle has been driven (the engine has been running) for 4 consecutive hours.

WARNING

- › While the vehicle speed remains less than 65 km/h, the system will not activate the warning even if the driver shows signs of fatigue.
- › In some situations, the driver's abilities may be unaffected even though he/she is fatigued. In such circumstances, the system will not issue a warning to the driver. For this reason, when the driver shows signs of fatigue, it is very important to stop the vehicle and rest in a timely manner, regardless of whether the driver condition monitoring system has issued a warning.
- › This feature cannot be used to loosen driving restrictions. Regular stops must be arranged during the long driving for adequate rest.

Functional limitations

When the fatigue driving reminder function is turned on, the following situations may cause the fatigue driving reminder function to be limited or not work at all:

- › Cruise control function activated
- › The front wiper is on.
- › The wiper control combination switch is currently being operated.
- › The driver side door is open. Depress the brake pedal.
- › The hazard warning lamp is on.
- › The driver's seat belt is not used.
- › The turn signal lamp is on.

Cruise control system

Vehicle equipment

Please note that this manual contains all the standard equipment, country-specific equipment and special equipment for this model series. Thus, some equipment or features described in this manual may not be installed onto your vehicle or are only available in some markets. For further configuration information, please refer to relevant sales information or consult with your distributor selling the vehicle to you.

Cruise control system introduction

While driving at high speed on straight, smooth highways, the cruise control system allows the user to keep the vehicle at a certain speed without stepping on the accelerator pedal for extended periods of time.

⚠ WARNING

- › The cruise control system is an auxiliary tool and cannot take the place of the driver in judging the road and traffic conditions nor the driver's driving. In any case, the driver shall be responsible for the safety of the vehicle and must concentrate on driving carefully at all times.
- › In order to avoid operating the cruise control system by mistake, if you do not use it, turn the cruise control system off.
- › Incorrect use of the cruise control system can lead to the collision accidents.
- › You should only use the cruise control system when there is good weather and the vehicle is traveling on straight highway.
- › Using cruise control system in urban areas, on meandering roads, on wet and slippery roads, or in other adverse weather conditions is not recommended.
- › Do not use the cruise control system when traveling on slopes. The system cannot maintain a set speed while the vehicle is traveling uphill or downhill.

- › The driver must not leave his or her seat when the cruise control system is activated.
- › To keep fuel economy, do not drive at a low speed under a higher gear, or drive at a high speed under a lower gear.
- › If the cruise control system is in operation and you want to slow down quickly, press brake pedal as usual.

Instructions

i NOTICE

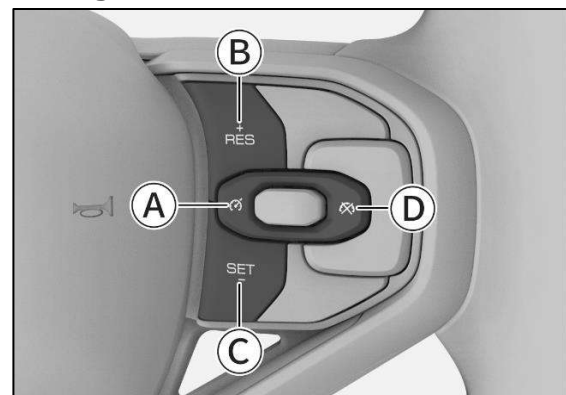

Since the cruise control system is designed for driving on highway and other roads with good conditions, the cruising speed should be within the range of 30 to 150 km/h.



62275BE701A9



- (A) ON/OFF button
- (B) Restore speed setting/acceleration button
- (C) Speed setting/deceleration button
- (D) Speed release setting button

Turning on the system

1. Press the  button to light  up the CCS indicator light on the instrument cluster, indicating that the cruise control system has been turned on.
2. Adjust to the required speed, then press the  button. The current speed is set and the vehicle is running at this speed. The cruising speed setting information will be displayed on the multi-information display of the instrument cluster.



Increasing the cruising speed

There are three methods to increase the set speed:

- > Press the  button to increase the speed.
- > Press and hold  button to increase the speed continuously.
- > Step on the accelerator pedal to accelerate to the desired speed, and press  button to set a new speed.

Reducing the cruising speed

There are three ways to reduce the cruising speed:

- > Press the  button to reduce the speed.
- > Press the  button to reduce the speed continuously.
- > Step on the brake pedal to reduce the vehicle to the required speed, then press the  button to set a new speed.

Accelerating temporarily

To accelerate temporarily during vehicle speed setting, depress the accelerator pedal. After acceleration, release the accelerator pedal to resume the previously set speed.

Cancelling the set speed

There are two ways to cancel the set speed:



- > Depress the brake pedal.
- > Press the set speed release button  on the steering wheel.

When the set speed is cancelled, the system does not turn off and the CCS indicator on the  instrument cluster remains on.

Restore the set speed

When you have cancelled the set speed, the system does not turn off. When the speed meets the system requirements, pressing the  button will automatically return to the speed set before it was cancelled. The cruise setting information will be shown again in the information centre.

Turning off the system

Press the  button to close the cruise control system and cancel the previously set speed and the  indicator light on the instrument cluster will go out.

Cruise control assist system

Vehicle equipment

Please note that this manual contains all the standard equipment, country-specific equipment and special equipment for this model series. Thus, some equipment or features described in this manual may not be installed onto your vehicle or are only available in some markets. For further configuration information, please refer to relevant sales information or consult with your distributor selling the vehicle to you.

System description

While you drive on straight, smooth highways, the cruise control assist system allows you to keep the vehicle at a certain speed without stepping on the accelerator pedal. When the system detects that the vehicle in front of you is driving at a speed less than the cruising speed set by your vehicle, the vehicle will be running by following the preceding vehicle at a set safe distance.

The vehicle equipped with the intelligent cruise control assist mode can also keep driving in the middle of the lanes during cruising.

WARNING

- › The cruise control system is an auxiliary tool and cannot take the place of the driver in judging the road and traffic conditions nor the driver's driving. In any case, the driver shall be responsible for the safety of the vehicle and must concentrate on driving carefully at all times.
- › When cruise control assist system is not in use, turn it off to avoid incorrect operation.
- › Incorrect use of cruise control assist system may result in a crash.
- › The cruise control assist system can only be used when you drive on a clear road in good weather conditions.

- › The cruise control assist system is not recommended for use in conditions such as urban areas, winding roads, narrow roads, wet and slippery roads, heavy rain or other harsh weather conditions.
- › When you drive on a slope, the cruise control assist system is not recommended for use, based on the following point :
The cruise control assist system cannot maintain the set speed when you drive up and down the slope.
After a preceding vehicle has passed the top or bottom of a slope, the cruise control assist system may not detect the preceding vehicle, causing sudden acceleration or late braking.
- › The cruise control assist system may exit when camera is illuminated by strong light or the illumination intensity changes suddenly. The camera may be affected when the front windscreen around the camera is polluted, frozen, damaged or covered.

Instructions

i NOTICE

Since the cruise control system is designed for driving on highway and other roads with good conditions, the cruising speed should be within the range of 30 to 150 km/h.

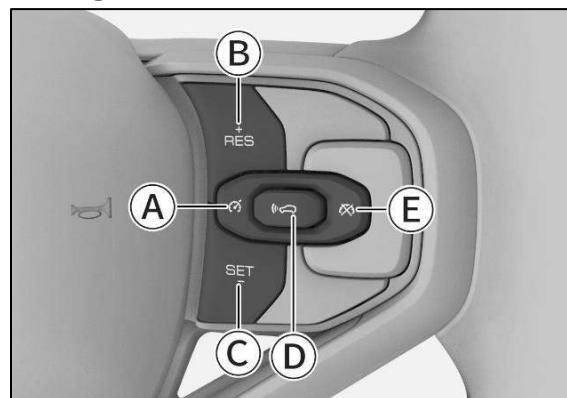

147410C8D101

- (A) ON/OFF button
- (B) Restore speed setting/acceleration button
- (C)

- (D) Speed setting/deceleration button
- (E) Distance level adjustment button
- (F) Speed release setting button

Instrument cluster display

i NOTICE



Due to different vehicle configurations or different instrument themes, the graphics displayed on the instrument cluster are for reference only. Refer to the actual vehicle.





- (A) Setting the speed
- (B) Distance level
The distance level is not a fixed distance, but a following distance between your vehicle and the preceding vehicle. The following distance between your vehicle and the preceding vehicle will vary with the speed of your vehicle under the same distance level.
- (C) Following distance display When the system detects the presence of a vehicle ahead, it will determine the degree of danger of the current following distance based on the speed of the vehicle, and display it in different colours.
- (D) Lane marking



Turning on the system

After the engine is started, press the ON/OFF button  on the steering wheel repeatedly to

select the adaptive cruise control assist mode () or TJA mode () or to turn off (OFF).

- > The indicator light (white)  on the instrument cluster turns on to indicate that the adaptive cruise control assist mode is on.
- > The indicator light (white)  (on the instrument cluster turns on to indicate that the TJA mode is on.

Setting the cruising speed

Press the  button to set the vehicle speed. After the vehicle speed is successfully set, the adaptive cruise control system indicator  or intelligent cruise control assist indicator  on the instrument cluster turns from white to green. The minimum set speed of the cruise control assist system is 30 km/h.

i NOTICE

When the adaptive cruise control assist mode is activated, the following basic conditions must be met before the cruising speed can be set:

- > All doors are completely closed.
- > The driver wears the seat belt properly.
- > The engine is started and the D gear position is engaged.
- > The ESC is activated.
- > No parking brake is applied.
- > The vehicle speed is less than 150 km/h.
- > The vehicle driving mode is in the standard, ECO or sport mode.



When the intelligent cruise control assist mode is activated, the following basic conditions must be met before the cruising speed can be set:

- > All doors are completely closed.
- > The driver wears the seat belt properly.
- > The engine is started and the D gear position is engaged.
- > The ESC is activated.

- › No parking brake is applied.
- › The vehicle speed is less than 150 km/h.
- › The system detects a lane marking.
- › If the vehicle speed is less than 60 km/h, it is required to detect the moving targets.
- › The vehicle driving mode is in the standard, ECO or sport mode.

Increasing the cruising speed

There are three methods to increase the set speed:



- › Press  button to increase the speed.
- › Press and hold the  button to increase the speed continuously.
- › Step on the accelerator pedal to accelerate to the desired speed, and press  button to set a new speed.

NOTICE

The vehicle will accelerate to the set speed only when the road ahead is clear. Otherwise, it will follow the vehicle in front according to the set distance.

Reducing the cruising speed

There are three ways to reduce the cruising speed:

- › Press the  button to increase the speed.
- › Press the  button to reduce the speed continuously.
- › Step on the brake pedal to reduce the vehicle to the required speed, then press the  button to set a new speed.

Accelerating temporarily

To accelerate temporarily during vehicle speed setting, depress the accelerator pedal. After acceleration, release the accelerator pedal to resume the previously set speed.

Adjusting distance level

Press the distance level adjustment button on the steering wheel to adjust the following distance to the front vehicle.

WARNING

Setting a low distance level may result in a delay in reaction in the event of unexpected situations, and it is always your responsibility to adjust the distance level appropriately.



NOTICE

- › The distance level is not a fixed distance, and the actual distance between your vehicle and the preceding vehicle will vary with the speed of your vehicle.
- › Select a higher distance level when driving on wet and slippery roads than when driving on dry roads.

Canceling the set speed

There are two ways to cancel the set speed:

- › Depress the brake pedal.
- › Press the set speed release button  on the steering wheel.

After the set speed is cancelled, the system is not turned off, and the adaptive cruise control system indicator light  or intelligent cruise control assist indicator light  on the instrument cluster turns from green to white.

NOTICE

The set speed will be automatically cancelled under any of the following circumstances:

- › Depress the accelerator pedal to make the vehicle accelerate for more than 15 minutes.
- › The N, R or P gear position is engaged.
- › The driver seat belt is released.
- › The driver door is opened.
- › The parking brake is applied.
- › The anti-lock brake system (ABS) is activated.
- › The HDC is activated.
- › The ESP is activated/deactivated.
- › The vehicle rolls backwards.
- › The brake disk is overheated.
- › The engine is shut down.
- › The vehicle driving mode is in the nonstandard, ECO or sport mode.

Restore the set speed

When you have cancelled the set speed, the system does not turn off. When the speed meets the system requirements, pressing the  button will automatically return to the speed set before it was cancelled. The cruise setting information will be shown again in the information centre.

Turning off the system

Press the ON or OFF button  repeatedly to select OFF. The system is turned off and the previously set speed and gap is cancelled.

Queuing auxiliary function

This function enables the vehicle to follow another vehicle within the speed range of 0~150 km/h.

In the event of traffic congestion, the vehicle can be slowed down to a stop following the preceding vehicle. At this point:

- › If the preceding vehicle leaves within 3 s, the vehicle will automatically follow the preceding vehicle.
- › If the preceding vehicle stops for a long time (3 s to 3 min), either push the control rod upwards or lightly step on the accelerator pedal can restart the system.
- › If the preceding vehicle is parked for more than 3 minutes, the vehicle will automatically apply the parking brake.
- › If the driver opens the door or releases the seat belt, the vehicle will automatically apply the parking brake.

NOTICE

After the cruise function is cancelled, the queuing auxiliary function is automatically disabled.

Curve road auxiliary function

When cruise assist system is enabled, if the vehicle is entering a curve road at too high speed, the curve road auxiliary function will reduce the vehicle speed appropriately.

WARNING

- › When entering and exiting a curve road or driving in a curve road, the system may not detect the vehicle in front of the same lane in a timely manner, in which case the vehicle may be braked too late, and the driver must be careful and ready to control the vehicle.
- › When driving around a curve road, the system may incorrectly detect vehicles in other lanes, causing unnecessary braking.
- › When driving on a sharp turn road (for example, a serpentine road), if the vehicle in front exits the sensor detection scope, the vehicle may suddenly accelerate, and the driver must be cautious and ready to manipulate the vehicle.

Lane center keeping function during cruising

This feature is only available in TJA mode, which assists the driver in keeping the vehicle in the middle of the lane boundary when the system is operating and the sensor detects a lane boundary or a moving vehicle ahead.

NOTICE

- › This feature is not available in adaptive cruise control mode.
- › This function is cancelled at the same time when the set cruise speed is cancelled.

CAUTION

In some cases, the lane center keeping function may not work properly or not work during cruising. For example,

- › Cruise at a speed higher than 60 km/h (including 60 km/h), there are no lane lines,
- › lane lines at both sides are blurred, and the non-standard lane boundaries or lane boundaries are covered.
- › Cruise at a speed below 60 km/h, there are no lane lines or the lane lines on both sides are blurred, the non-standard lane boundaries or the lane boundaries are covered, and there is no vehicle running ahead.
- › There is an object on the road that affects the identification of the lane boundaries (such as water, gaps, ruts, text signs, bumps or pits).
- › Low visibility (such as rain, snow, fog and night etc.). The vehicle is strongly affected by the side wind.
- › The lanes merge or separate.
- › The camera is illuminated by strong light or the illumination intensity changes suddenly.
- › The front windshield around the camera is polluted, frozen, damaged or covered. Vehicles are running on a sharp turn or a narrow road.
- › If the vehicle is driving too close to the preceding vehicle, the camera detection scope is hindered.

- › A vehicle is running at a low speed in front of you when you are driving at a speed of over 60 km/h.
- › An oncoming vehicle is running in the same lane.
- › A vehicle or object that crosses a lane.
- › Pedestrians or animals and small vehicles (such as bicycles and motorcycles) are seen.
- › The vehicle in front decelerates suddenly.
- › Water, snow or mud splashed by surrounding vehicles hinders the sensor detection.
- › The vehicle head tilts up due to overload in the luggage area.
- › The vehicle is running on a winding or narrow road.
- › The preceding vehicle has a relatively small tail dimension or very large ground clearance.

Sensor

The cruise assist system identifies lane boundaries and detects targets through the camera above the front windshield.

NOTICE

When the combination instrument indicates that the system sensor detection is restricted, please check and ensure the camera and its surroundings are clean and free of obstructions so that the system can operate properly.

Functional limitations of the cruise assist

Under the following conditions, the cruise assist system may not take the braking measures:

- › A vehicle suddenly appears in front of you.

Intelligent driving assist system

Vehicle equipment

Please note that this manual contains all the standard equipment, country-specific equipment and special equipment for this model series. Thus, some equipment or features described in this manual may not be installed onto your vehicle or are only available in some markets. For the further configuration information, please refer to relevant sales information or consult with your distributor selling the vehicle to you.

Intelligent driving

After starting the vehicle, via the [Vehicle Setting] → [Driving] on the multimedia to set the corresponding functions.

WARNING

The intelligent drive assist system is only an auxiliary tool. It can not use as a substitute for the driver's judgment of road and traffic conditions, nor it can replace the driver's driving. In any case, the driver shall be responsible for the safety of the vehicle and must concentrate on driving carefully at all times.

The driver must always keep his hands on the steering wheel and ready to turn at any time.

Sensor

Intelligent drive assist system identifies lane boundaries and detects targets through the following components.

- > Camera.
The camera is located on the upper part of the front windshield.
- > Sensor
Sensors are located on both sides of the rear bumper.

NOTICE

When the instrument indicates that the system sensor detection is limited, check that the camera, sensor, and surrounding area are clean and clear of obstructions to ensure proper system operation.

NOTICE

1. This communication device conforms to standards or technical requirements of NBTC.
2. The electromagnetic field intensity of this communication device conforms to Safety Standard for People to Use Communication Device Healthily published by National Telecommunications Commission.

Forward assist system

The forward assist system identifies vehicles on the lane via a camera on the front windscreen. When the risk of collision ahead is detected, the system will issue an alarm or conduct brake intervention to mitigate the consequences of the accident.



695A11F62AE3

⚠ WARNING

We cannot guarantee that this system will function as expected in all situations. Therefore, it is prohibited to drive the vehicle toward a pedestrian, animal or other vehicles for the purpose of testing the system, which could cause serious injury or death.

In complex driving conditions, the system may apply unnecessary braking. This may happen, for example, in construction sites, at railway tracks, and when water is sprayed or splashed in front of the vehicle.

The system may not work properly when there is low visibility (e.g. rain, snow, fog and haze, night, etc.). The system may exit when the camera is illuminated by strong light or the illumination intensity changes suddenly.

The camera may be affected when the front windscreen around the camera is polluted, frozen, damaged or covered.

Pedestrian/collision safety assist

Pedestrian safety assist : it can detect passengers and cyclists.

Collision safety assist : it can detect most vehicles stationary or driving in the same direction as your vehicle (such as passenger cars, trucks, buses, etc.).

› Without braking: the function is turned off.

› Brake: the function is turned on.

When the vehicle speed exceeds 30 km/h and the system detects that there is collision risk for pedestrians or vehicles, it will give an alarm to prompt the driver to drive safely. There are 2 alarm levels: audible alarm (pre-alarm), short brake alarm (emergency alarm).

In case of emergency, if the driver does not apply the brake, the system will control the vehicle to automatically perform emergency braking (limited braking), and the left and right turn signal lamps will flash quickly to remind the rear vehicle, so as to reduce the collision risk.

i NOTICE

- › At low vehicle speeds, this function may slow the vehicle to a standstill, but will not keep the vehicle stationary. At this point, the driver should apply the brake actively.
- › If the driver steps on the accelerator pedal or turn the steering wheel during the emergency braking, the system will disengage the emergency braking.

i NOTICE

- › If the vehicle speed exceeds 65 km/h and the system determines that the distance between your vehicle and the vehicle ahead is too close, the instrument cluster will show the prompt message of "Please keep a safe distance".
- › When cruise control assist system is working, the safe distance alert function is blocked.
- › Poor lighting will affect the detection range. Turn on the headlamps when driving at night.

Detecting the target

i NOTICE

For valid targets identified by the system, the system may not always achieve the same level of performance, depending on vehicles, pedestrians, scenes, road conditions.

- › The cyclist must be an adult and the bicycle must be designed for an adult. The system can only work best when it detects clear information about the body and the contour of the bicycle, which means that the system needs to clearly identify contour information such as the bike, head, arm, shoulder, thigh, and the normal cycling of the person.
- › The system detects pedestrians in contrast to the background (e.g., the color of the pedestrian clothing is contrasting with the color of the surrounding environment). If the contrast is low, the pedestrian will be detected later or not at all, meaning that warnings and braking will be delayed or unavailable.

The system can only work best when it detects clear information about the shape of the body, which means that the system needs to clearly identify information about the head, arm, shoulder, thigh, etc. of the person and the normal walking pattern of the person.

Intersection assistance

When the vehicle speed is lower than 20 km/h, and the vehicle turns around at a intersection, if an oncoming vehicle or a pedestrian is detected and there is a risk of collision, the system will apply brake.

The system can detect pedestrians and vehicles driving in the opposite direction of your vehicle (such as passenger cars, trucks, buses and so on). Poor lighting will affect the detection range. Turn on the headlamps when driving at night.

Front collision warning sensitivity

Sensitivity is divided into three levels.

- › Standard: it indicates that the distance is normal when an alarm is sounded as defined by the system.
- › Low: it indicates that the distance is shorter when an alarm is sounded.
- › High: it indicates that the distance is longer when an alarm is sounded.

Lane keeping assist system

The lane keeping assist system is designed for a vehicle travelling on motorways, and other roads in good condition. By using a camera on the windscreen to detect lane markings, it reminds the driver to make a correction when the driver accidentally deviates from the lane. Some of the system functions even assist the driver in correcting the direction to reduce the risk of a collision.

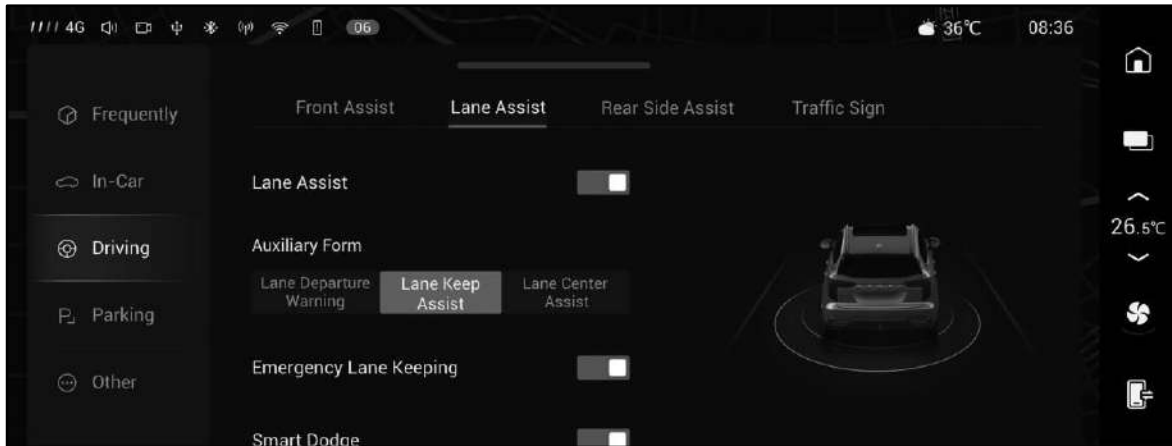

18D239526562

⚠ CAUTION

The lane keeping assist system properly works only when the lane marking is clearly visible. It may not work properly or even not work in some cases. For example:

- › Lane markings are unclear, non-standard, or otherwise obscured.
- › There are objects on the road that affect the identification of lane markings (e.g. water, cracks, ruts, signs, crosswalks, bumps and pits, etc.).
- › There is low visibility (e.g. rain, snow, fog and haze, night, etc.).
- › The vehicle is strongly affected by the crosswind.
- › The lanes merge or separate.
- › A strong light shines on the camera, or the light intensity abruptly changes.
- › The front windscreen around the camera is polluted, frozen, damaged or covered.
- › The vehicle is running on a sharp turn, a narrow road, or a road prone to rollover.
- › The vehicle is running too close to the preceding vehicle, and the camera detection scope is hindered.

i NOTICE

If you turn on the turn signal lamp, turn the steering wheel, operate the accelerator pedal or the brake pedal before passing through a lane marking, the system will not send an alarm. In this case, the system considers you are taking the initiative to drive the vehicle.

i NOTICE

When the driver controls the steering wheel with a small force, the system may not detect the driver's hand holding the steering wheel, and the instrument cluster will send an alarm.

Lane keeping assistance

When the lane keeping assistance function is turned on, the keeping assistance form can be selected.

- › Lane departure warning: it can warn the driver to drive safely when the driver deviates from the lane unconsciously.
- › Lane keep assist: it can assist the driver to correct the steering wheel to keep the vehicle in the lane when the driver deviates from the lane unconsciously. If the correction fails, the system will give an alarm to alert the driver to drive safely.
- › Lane center assist: it can assist the driver to correct the steering wheel to control the vehicle to drive in the centre of the current lane. If the correction fails or the vehicle is off the current lane, the system will give an alarm to alert the driver to drive safely.

i NOTICE

The lane keeping assistance function can only work when the vehicle speed is within 60 to 150 km/h.

When the lane keeping assistance function is turned on, the lane markings will be displayed on the instrument cluster.

- › Grey: it indicates that the system fails to detect a lane marking.
- › Green: it indicates that the system detects a lane marking or it is correcting the steering wheel.
- › Red and flashing: it indicates that the system sounds an alarm, and the driver needs to correct the direction in time to make the vehicle return to the lane.

i NOTICE

The lane center assist functions only when the system identifies the lane markings on the left and right sides.

Emergency lane keeping (ELK)

When the emergency lane keeping is turned on, the system will more actively correct the steering wheel in case of an emergency to reduce the risk of collision. For example:

when the driver is unaware of lane deviation or turns on the turn signal lamp to change lanes, there is a risk of collision with the oncoming vehicle in the adjacent lane or a vehicle from the rear in the same direction, or there is a curb or a pit outside the lane.

i NOTICE

The emergency lane keeping functions only when the vehicle speed is within 60 to 150 km/h.

⚠ WARNING

In some cases, the emergency lane keeping function may not work properly or not work. For example :

- › For smaller targets (motorcycles, bicycles, etc.)
- › For stationary targets
- › The current vehicle is moving too close to the preceding vehicle and prevents the camera from detecting it.
- › The rear vehicle is driving too close to the current vehicle and prevents the sensor from detecting it.

Wisdom dodge function

After the wisdom dodge function is turned on, if the lane center assist or intelligent cruise control is turned on and in working condition, when the system identifies that the vehicle is about to overtake the adjacent large vehicles (wagon, truck, bus, etc.), it will control the vehicle to move slightly away from the large vehicle. After overtaking the large vehicle, your vehicle will return to the central area of the current lane.

i NOTICE

The wisdom dodge function will not begin to work until the vehicle speed reaches 60 to 140 km/h.

⚠ CAUTION

The following situations may not trigger the wisdom dodge function:

- › The system detects that there is a large vehicle on the adjacent lane on one side, and there are vehicles on the adjacent lane on the other side or the adjacent lane on the other side is a curb.
- › The vehicle is driving in severe weather such as night, heavy fog, rain and snow.
- › The vehicle is in a curve.

Early warning mode

There are three warning modes: sound, vibration, and sound + vibration.

Early warning sensitivity

Sensitivity is divided into three levels: low, standard and high.

Rear side assist system

The rear side assist system can detect vehicles behind your vehicle or in the adjacent lane through sensors on both sides of the rear bumper. If there is a risk of collision, the system will issue an alarm to remind the driver to drive safely.

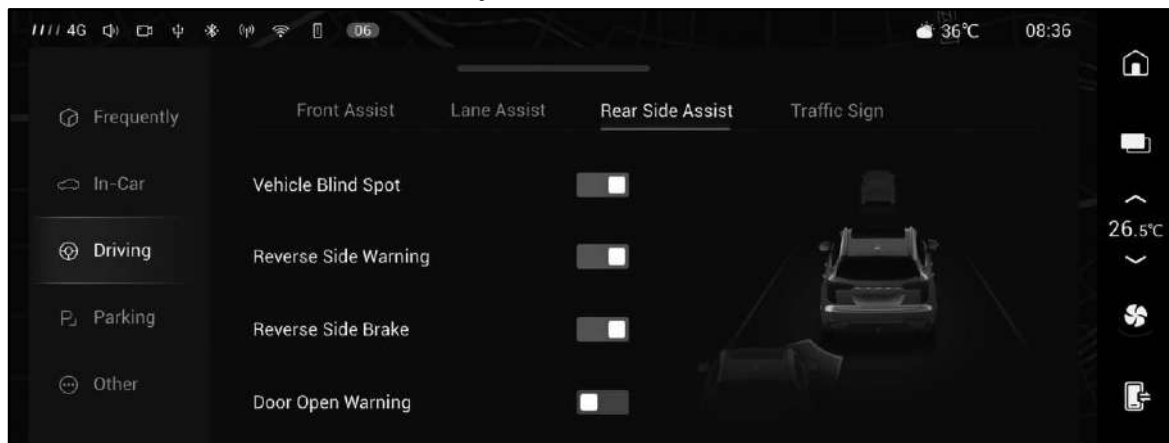

ED5AF2C2219D

i NOTICE

- › Keep both sides of the rear bumper clean, and do not paste any objects and cover any ice, snow, mud and other foreign objects, so as not to affect the normal work of the sensor.
- › Improper repair or modification of the vehicle may cause the sensors to be dislocated, which may affect the proper operation of the rear side assist system. Therefore, it is recommended that you maintain and repair your vehicle at the authorized service centre.
- › Turn off the rear side assist system when towing other vehicles.

⚠ WARNING

In some cases, it may not work properly or even not work. For example:

- › For stationary targets (vehicles, pedestrians, etc.)
- › Driving in bad conditions such as rain, snow, etc.
- › Driving on a sharp bend, a sloping road, a wide or narrow lane

Warning light



C8364549158A

The warning lights are located on the surfaces of the left and right side mirrors.

⚠ WARNING

Do not paste any objects on the warning lights to avoid affecting the system's alarm function.

Doubling assistance

During driving (with the speed exceeding 15 km/h), when the system detects that there is a vehicle in the blind area of the side mirrors or a quick approaching vehicle behind the adjacent lane, the warning light on the corresponding side should be on. If you turn on the turn signal lamp at the same side at this time, the warning light turns to flash and an audible alarm is accompanied, which indicates that there is danger if continuing to change the lane.

Door open warning

When the system detects that there are approaching vehicles and bicycles and other targets in the adjacent lanes on both sides after the vehicle stops and that there is a risk of collision when the door is opened, the warning light at corresponding side will go on. If the passenger continues to open the door on the corresponding side at this point, the warning light will flash and an audible alarm will sound to indicate that it is dangerous to continue opening the door.

NOTICE

The door open warning system will only function in the following conditions:

- › When the vehicle power supply is in ON mode.
- › Within 3 minutes of switching the power supply mode from ON to OFF mode.

Rear collision warning

When the system detects that there is a fast approaching vehicle behind the subject vehicle and there is a risk of collision, the left and right turn signal lamps will flash quickly, accompanied by an audible alarm and instrument prompts to remind the driver of the subject vehicle that a dangerous target is approaching, and warning the driver of rear vehicle to drive safely.

Reverse side warning

When the reverse side warning function is enabled, if during reversing the system detects that there is a risk of collision with a moving vehicle in the blind area of the side mirror, it will give an alarm to remind the driver to drive safely.

When the reverse side brake function is enabled, limited braking can be applied when there is a risk in reversing, reducing the risk of collision.

CAUTION

The reverse side assistance function is limited in some cases. For example,

- › There are obstacles blocking. The system cannot detect objects behind other parked vehicles or obstacles.
- › The current vehicle speed is too high or too low.
- › The driver steps on the accelerator pedal firmly.
- › The driver turns the steering wheel quickly.

Traffic sign information

The traffic sign information function is used to recognize the traffic signs through the camera on the front windshield and display them on the combination instrument to give a prompt to the driver.

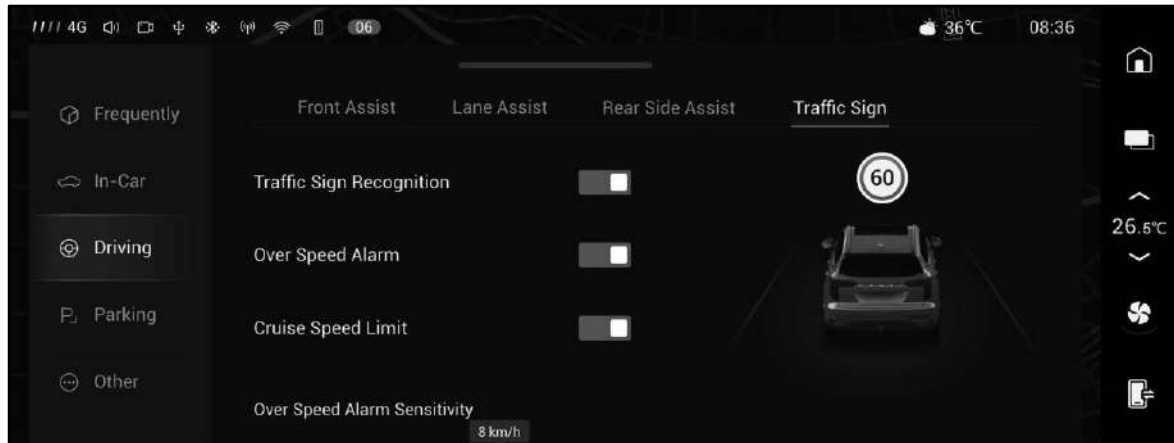

39B727C42845

Traffic sign recognition

After the traffic sign recognition function is activated, the traffic sign can be recognized and displayed on the combination instrument to remind the driver.

Overspeed alarm

After the traffic sign recognition function is activated, the overspeed alarm function can be enabled. After the speed limit sign is recognized, in case of overspeed, the system will give an alarm to remind the driver to reduce the speed to a suitable range as soon as possible.

Speed alarm sensitivity

The alarm timing for overspeed can be set according to your driving habits.

- > 0 : Alarm will be issued when the vehicle speed reaches the speed limit.
- > > 0 : Alarm will be issued only when the vehicle speed exceeds the speed limit.
- > < 0 : Alarm will be issued in advance when the vehicle speed does not reach the speed limit.

Cruising speed limit function

After the traffic sign recognition function is enabled, the cruising speed limit function can be enabled. When the vehicle is running in a cruise control mode, if the system recognizes a speed limit sign showing the speed is ≥ 30 km/h and the cruising speed is higher than the speed limit of the sign, the system will assist the driver to reduce the vehicle speed to be within the allowable maximum speed limit.

⚠ WARNING

The traffic sign information function is designed to alert the driver to traffic signs and is not intended to be used in all cases and is not a substitute for the driver's judgment on road speed limit messages. In all cases, the driver is responsible for the safety of the vehicle and must always drive with care and comply with applicable laws and road traffic regulations.

⚠ CAUTION

The traffic sign information function can work properly only when the speed sign is clearly visible. It may not work properly or even not work in the following cases: For example:

- › A sign fades.
- › A sign is on the bend.
- › The sign is not properly positioned.
- › A flag is rotating or has been damaged.
- › A sign is fully or partially blocked.
- › A sign is fully or partially covered by frost, snow, dust, etc.
- › A high-speed sign is placed in the position that is too far or too high.
- › A speed limit caution or sign is attached to the road surface.
- › Low visibility (such as rain, snow, fog and night etc.).
- › The camera is illuminated by strong light or the illumination intensity changes suddenly.
- › The front windshield around the camera is polluted, frozen, damaged or covered.
- › If the vehicle is driving too close to the preceding vehicle, the camera detection scope is hindered.

i NOTICE

- › The speed limit sign identified by the system shows the default speed unit of xx km/h.
- › For multiple speed limit values on the same speed limit sign, the system will show the maximum value.
- › When multiple speed limit signs are arranged in parallel, the system will display the maximum speed limit value. Please take the actual speed limit value of the current lane as the criterion.
- › When the vehicle is turning, the speed sign may not be identified.

Hill descent control system

Vehicle equipment

Please note that this manual contains all the standard equipment, country-specific equipment and special equipment for this model series. Thus, some equipment or features described in this manual may not be installed onto your vehicle or are only available in some markets. For further configuration information, please refer to relevant sales information or consult with your distributor selling the vehicle to you.

Hill descent control system

introduction

While going downhill, the hill descent control system (HDC) may actively brake to ensure that the driver can maintain a constant speed and drive downhill safely.

WARNING



- › HDC is intended only to be an aid. At all times the driver should be responsible for the safety of the vehicle, and always pay attention to the surrounding traffic.
- › In case of too high slope, the HDC may not function and thus the vehicle can't be driven down the slope at even speed. At this time, you can control the vehicle speed by stepping on the brake pedal.

Instructions



F387743687FE

When the power supply is set to ON mode or the engine is running, press the button to turn on or off HDC.

- › After HDC is turned on, the HDC indicator light  on the instrument cluster goes on.
- › After HDC is turned off, the HDC indicator light  on the instrument cluster goes off.
- › When HDC is working, the HDC indicator light  on the instrument cluster flashes.

NOTICE

- › It is recommended that HDC should be used in a lower gear position.
- › HDC will automatically turn off when the vehicle speed is greater than 60 km/h.
- › With HDC turned on, the speed can still be adjusted by depressing the brake pedal or the accelerator pedal.

Vehicle equipment

Please note that this manual contains all the standard equipment, country-specific equipment and special equipment for this model series. Thus, some equipment or features described in this manual may not be installed onto your vehicle or are only available in some markets. For further configuration information, please refer to relevant sales information or consult with your distributor selling the vehicle to you.

Tips for safety

About traffic safety

Never take a risk in driving because the vehicle is equipped with driving assist systems and always ensure that the vehicle speed and driving style adapt to visibility, weather, road and traffic conditions.

About modification

Suspension modification or use of tyres or wheels of non-specified size will impact driving assist systems and may cause system malfunctions.

About sound and vibration

- › vibration may be created by some driving assist systems (such as ABS) during work or the sound of the motor working may be heard, which does not indicate a malfunction.
- › When you jump start the vehicle due to drained battery power, the engine may not run smoothly and the warning lamps of ABS or the ESC may be turned on, which results from the low battery voltage instead of the failure of the ABS or the ESC.

Anti-lock brake system

During emergency braking, or when braking is applied during driving on wet and slippery road, the anti-lock brake system (ABS) helps

prevent wheels from locking to maintain steering control of the vehicle.

CAUTION

During emergency braking, do not step on the brake pedal several times and gently. Otherwise, it will lengthen the braking distance.

The ABS is not designed to shorten the braking distance of the vehicle. Especially in the following cases, compared with vehicles not equipped with the ABS, your vehicle may require a longer braking distance. Be sure to maintain adequate safe distance from the vehicle in front of you:

- › when driving on muddy, gravel or snowy road.
- › when driving with tyre chains in place.
- › when driving on bumpy road.
- › when driving on potholes or uneven road.

The ABS may not work effectively:

- › when the limit of tyre grip performance is exceeded (like using excessive wear tyre on snowy road).
- › when driving at a high speed on wet and slippery road.

Electronic braking force distribution system

The electronic braking force distribution (EBD) system is capable of automatically adjusting the front and rear braking force ratio to enhance braking efficiency. It complements the ABS for greater braking stability and thereby vehicle stability.

Braking force assist system

Stepping on brake pedal very quickly can trigger the braking force assist system to help increase the braking effect and shorten the braking distance during emergency braking.

Traction control system

When you start or accelerate on a wet and slippery road, the traction control system (TCS) helps to keep a driving force and avoid driving wheel spinning.

Rollover prevention system

When the vehicle turns a corner, the rollover prevention system (RMI) determines whether there is a risk of rollover by monitoring the movement status of the vehicle. If any, RMI will decelerate one or more wheels to refrain the vehicle from a rollover accident.

Secondary collision mitigation system

The secondary collision mitigation system (SCM) will automatically apply the braking to the vehicle after the first collision (airbag deployment) to reduce the vehicle speed or stop the vehicle, thereby reducing the chance and injury of a second collision.

HHC (Hill-start Hold Control)

When the driver starts on a slope and releases the brake pedal, the hill-start hold control (HHC) can maintain the braking force for about 2 seconds to effectively avoid rolling.

WARNING

When starting on a slope greater than 30%, the vehicle may still roll. Therefore, do not excessively rely on this function. Please pay attention to the safety of driving.

Electronic power steering system

The electric power steering system can adjust the power in real time by monitoring the driving speed, so as to ensure the portability of low-speed steering and the stability of high-speed steering and enhance the sense of security.

Electronic stabilization program

Electronic stability control (ESC) can help reduce the risk of side slip, and improve driving stability by braking individual wheel under certain driving situation.

When ESC works, the ESC indicator  on the combination instrument flashes. Make sure to be careful at this time.

NOTICE

Generally speaking, ESC is on throughout the drive. The system can be turned off only under following special conditions:

- > When driving with tyre chains in place.
- > When driving in deep snow or on soft ground.
- > When the vehicle is stuck and you need to free it.

Turn on ESC again upon finish of above conditions.

Turning on/off the system



BB66AF3DEE89

After the vehicle starts, press the  ESC OFF button.

The  ESC OFF indicator on the combination instrument will light up, indicating that the system is shut down.

Press the button again to restart the ESC system.

NOTICE

The ESC will automatically start in the following conditions:

- > Every time you start the engine.
- > The vehicle speed exceeds 85 km/h.

Vehicle equipment

Please note that this manual contains all the standard equipment, country-specific equipment and special equipment for this model series. Thus, some equipment or features described in this manual may not be installed onto your vehicle or are only available in some markets. For further configuration information, please refer to relevant sales information or consult with your distributor selling the vehicle to you.

Tips for safety

The emission control system may vary with different engine models. For the particular equipment, please refer to the actual vehicle. Do not modify any part of the engine or emission control system.

Oxygen sensor

The oxygen sensor measures the concentration of oxygen in the exhaust gases and reports that information to the ECU in order to regulate the engine's fuel-air ratio for optimum combustion efficiency and to reduce the amount of carbon monoxide, hydrocarbons, and nitrogen oxides contained in the exhaust.

Catalytic converter

The catalytic converter is the most important external purifier installed in the vehicle's exhaust system. The catalytic converter contains the metallic catalysts that convert harmful gases such as carbon monoxide, hydrocarbons, and nitrogen oxides into harmless carbon dioxide, water, and nitrogen gas through oxidation and reduction reactions.

Do not disassemble the catalytic converter without cause, as it does not require maintenance as long as it is used correctly. Be sure to choose a catalytic converter that matches the engine for replacement.

CAUTION

To avoid damaging the catalytic converter, please pay attention to the following items:

- › Do not use leaded gasoline or gasoline with more than the standard amount of manganese or sulphur.
- › Do not drive the vehicle when the fuel level is extremely low. If the fuel is exhausted, it will cause the engine to misfire (this may be confirmed by unstable engine operation or a loss of power), damaging the catalytic converter.
- › Do not idle the engine at high speed for an extended time (5 minutes or longer).
- › When a problem with the engine is indicated (such as shutdown or performance degradation), please do not continue driving the vehicle.
- › Do not operate the engine with the spark plugs removed.
- › Do not start the vehicle by pushing or pulling it.
- › Do not add too much engine oil.
- › Please avoid striking the catalytic converter.

Fuel evaporation control unit

When the vehicle is running normally, the fuel evaporation control unit can make the fuel steam enter the engine to burn, so as to prevent the fuel steam from entering the atmosphere.

Crankcase emission control unit

The crankcase emission control unit guides the mixed gases within the crankcase (such as uncombusted fuel vapours, water vapour, and exhaust) through a connected pipe into an appropriate place in the air-intake pipe to return them to the cylinders and be combusted again. Thus, the exhaust gas can be reduced while the engine fuel economy improved.



On-board diagnostic system

The engine malfunction warning lamp is part of the vehicle's on-board diagnostic system.

The engine electronic control unit equipped with the on-board diagnostic system stores various fault information (especially when it comes to exhaust-emissions fault information).

The fault information will be cleared if the battery cables are disconnected, making a rapid diagnosis difficult. Thus, please do not disconnect the battery cables when investigating why the engine malfunction warning lamp has illuminated.

Head-up display (HUD)

Vehicle equipment

Please note that this manual contains all the standard equipment, country-specific equipment and special equipment for this model series. Thus, some equipment or features described in this manual may not be installed onto your vehicle or are only available in some markets. For the further configuration information, please refer to relevant sales information or consult with your distributor selling the vehicle to you.

About the system

The head up display (HUD) can project relevant information to an effective visual area within the driver's field of view. By using this system, the driver can check the vehicle information during normal driving without lowering head, thereby avoiding distracting the driver's attention from the road ahead, and preventing the eye fatigue when the driver switches the angle of view while observing the road ahead and the nearby instrument panel.

i NOTICE

- › Under certain special weather conditions (such as rain, snow, strong sunlight, etc.), the information displayed on HUD may be unclear or disturbed.
- › Certain sunglasses can affect information reading.

How to use

After the vehicle is started, the head up display (HUD) can be turned on or off via [Vehicle Settings] → [In-Car] → [HUD] on the multimedia display screen.

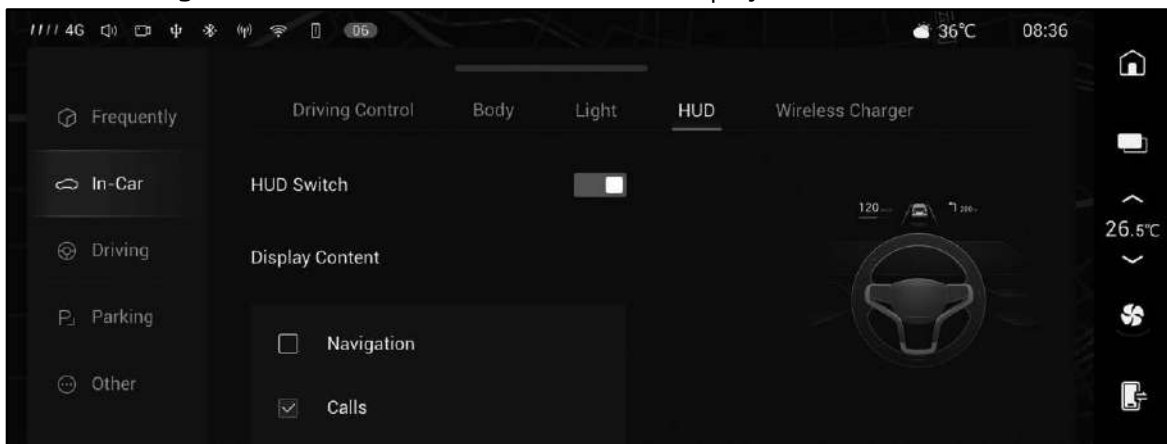

192126CDD40D

After the HUD is turned on, you can configure the following settings:

- › Set the display content of HUD projection interface.
- › Adjust the projection height, angle or brightness of HUD with steering wheel.

Virtual instrument

Vehicle equipment

Please note that this manual contains all the standard equipment, country-specific equipment and special equipment for this model series. Thus, some equipment or features described in this manual may not be installed onto your vehicle or are only available in some markets. For the further configuration information, please refer to relevant sales information or consult with your distributor selling the vehicle to you.

Summary

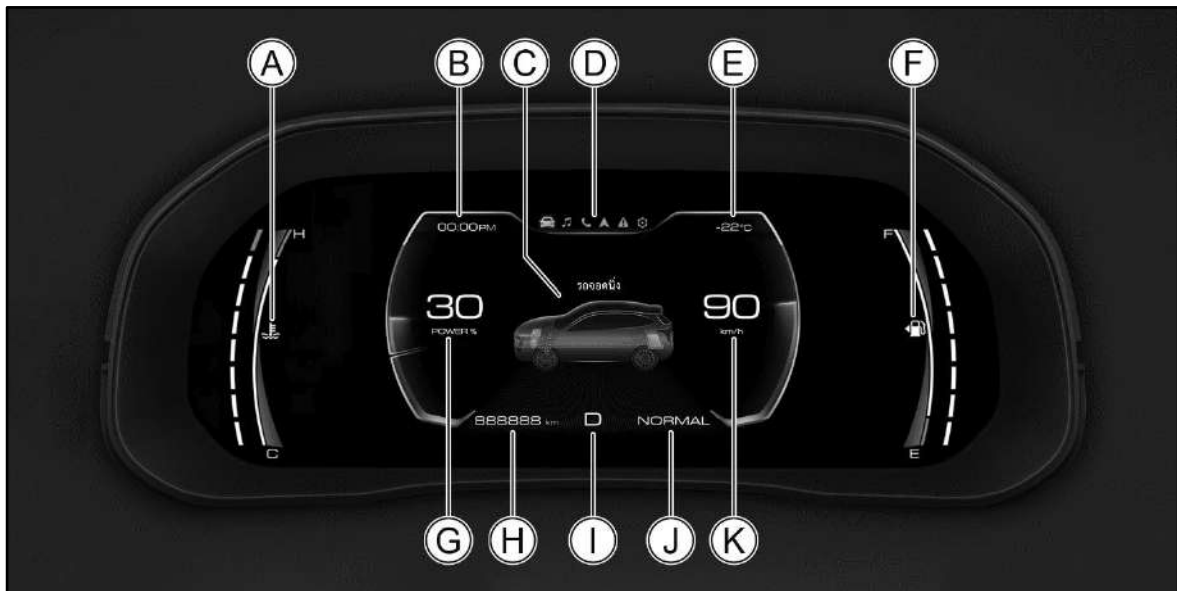

C55FOCA0EE4A

(A) Water temperature gauge

(B) Digital clock

(C) Information center

(D) Multi-function tab bar

(E) Outside temperature

(F) Fuel gauge

(G) Power meter

(H) Mileage

(I) Gear position display

(J) Driving mode

(K) Speedometer

Water temperature gauge

Display an approximation of the engine coolant temperature.

⚠ CAUTION

When the water temperature is close to the red warning zone, slow down your vehicle immediately and find a safe spot to park your vehicle for checks. Restart the engine only after water temperature in the engine has returned to normal.

Fuel gauge

Display the amount of fuel remaining in the fuel tank.

i NOTICE

When driving for an extended time on a slope or around a bend, the fuel-gauge needle may become unstable as fuel moves around in the tank.

Power meter

It displays the total power the vehicle input currently or the energy recovery power.

Speedometer







Display the current speed of the vehicle.

Information center

Switch the displayed content through the multi-function tab bar.

Multi-function tab bar

Select different function tabs to switch the content displayed on the multi-information display.

Tab	Meaning	Information center
	Driving data	It displays the mileage, vehicle speed, fuel consumption, journey time and other information related to vehicle operation.
	Audio media	It displays the audio media information that is currently playing.
	BT phone	It displays the information about the currently connected BT phone.
	Navigation information	It displays the map and navigation information
	Alarm messages	It displays the currently shielded primary alarm messages or the automatically hidden secondary alarm messages.
	Menu setting	The menu setting information can be displayed, and the instrument can be set accordingly.

i NOTICE

The audio media tab may be different based on the media source of the currently playing audio.

Steering wheel button

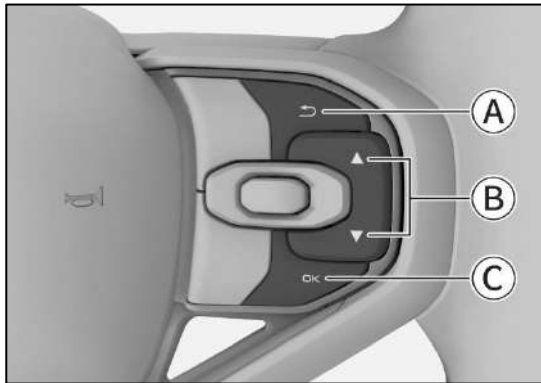

C191FAD95231

- (A) Back button
- (B) Page-turn button
- (C) OK button

Back button

Press the button to return to the previous menu. Press this button to switch the functions of the multi-function tab bar if there is no previous menu.

Page-turn button



If multiple pages or options are displayed on the multi-information display, press this button to turn pages to view or switch options.



OK button

Press this button to enter the next menu, confirm the current settings or shield the primary alarm messages currently shown.

Press and hold this button to temporarily shield all alarm messages currently shown or reset certain driving data interfaces.

Driving data interface

Press the Back button  on the steering wheel to switch to the driving data  interface.

Press the Up button  or Down button  on the steering wheel to switch the driving data shown on the multi-information display.

- > Digital speed: it shows the current driving speed in digital form in case the instrument is using dynamic theme.
- > Driving efficiency: it displays the economic status of the vehicle in the current driving mode.
- > Energy flow: it displays the working state of the power system and the state of charge of the power battery under the current working condition.
- > Tripmeter: it shows the mileage since the last reset.
- > Driving time: it shows the driving time since the last reset.
- > The driving time will automatically reset when it exceeds 99 hours 59 minutes.
- > Average speed: it shows the average vehicle speed since the last reset.
- > Average fuel: it shows the average fuel consumption since the last reset. Instant fuel: it shows the current fuel consumption information. This information can help you to adjust your driving behavior to achieve your desired fuel consumption level.
- > Range: it displays a prediction of approximately how far the vehicle can be driven based on the current fuel consumption in the fuel tank.
- > It shows "---" when the range is less than 50 km.

NOTICE



- > After refuelling, the range will be recalculated.
- > The actual driving distance will vary depending on driving habits and road conditions.
- > When the warning light  on the instrument cluster illuminates, you should refuel even if the display shows that the vehicle can travel farther.
- > TPMS: it shows the tyre pressure and temperature values.
- > Tachometer: it displays the current engine speed.

i NOTICE



The average fuel consumption, average vehicle speed, tripmeter and driving time are displayed on two data interfaces, i.e., A and B.

- › On the data interface A, the driving data within the current ignition cycle is displayed, and the power supply mode is turned to the OFF position; after 4 hours, the data will be automatically reset.
- › On the data interface B, the driving data from the last manual reset to the current time is displayed.
- › Press the OK button on the steering wheel when the tripmeter, average fuel consumption, average vehicle speed or driving time is shown on the multi-information display to switch between the data interface A and the data interface B.
- › Press and hold the OK button on the steering wheel when the tripmeter, average fuel consumption, average vehicle speed or journey time is shown on the multi-information display to manually reset the corresponding data on the data interface A or B.



Audio media interface

Press the back button  on the steering wheel to switch to the audio media  interface. At this time, the multi-information display will show the media information that is currently playing.

BT phone interface



Press the back button  on the steering wheel to switch to the BT phone  interface.



At this time, the multi-information display will show the call log information.

Press the up button  or down button  on the steering wheel to switch the selected call log entry.



Press the OK button on the steering wheel to dial the number of the currently selected contact.



Navigation information interface

Press the back button  on the steering wheel to switch to the Navigation information interface .

Press the up button  or down button  on the steering wheel to switch the can switch between of the navigation information interface.

Alarm information interface

Press the Back button  on the steering wheel to switch to the alarm information  interface.

Press the Up button  or Down button  to view all the currently shielded primary alarm messages and the automatically hidden secondary alarm messages.

Most alarm messages are accompanied by a corresponding alarm indicator light on the instrument cluster. When an alarm message is displayed, the corresponding alarm indicator light also turns on.

The alarm prompt message has priority over the driving data, and will be displayed first when the power supply mode is turned to ON. Please perform all and any operations strictly in accordance with instructions contained in alarm messages. If there are no relevant instructions available, please stop the vehicle for checks or contact authorised service centre for assistance.

CAUTION

- › Do not ignore alarm prompt messages. Failure to heed alarm messages can cause severe damage to the vehicle.
- › If an alarm indicator light goes on, please stop the vehicle as soon as possible and contact authorized service centre, while paying extra care to safe driving.

Important alarm messages



If there are multiple important alarm messages, they will be shown cyclically in turns. After an alarm condition is cancelled, the corresponding alarm message will not be shown at the same time.



Pressing the [OK] button on the steering wheel can shield important alarm messages (pressing the button can shield the important alarm messages currently shown, while pressing and holding the button can shield all important alarm messages), and  will be shown on the instrument cluster to remind you that the alarm messages have not been released.

Secondary alarm messages

Secondary alarm messages will disappear automatically after being shown for a few seconds.  will be shown on the instrument cluster to remind you that the alarm messages have not been released.

Menu setting interface



Press the back button  on the steering wheel to switch to the menu settings  interface.

Press the up button  or down button  on the steering wheel to scroll through the menu settings term by term.

Press the OK button on the steering wheel to enter the next menu or to confirm the current setting.

Overspeed settings

Press the OK button to enable or disable the speed alarm function.

After enabling the speed alarm function, press the up button  or down button  to adjust the speed alarm value.

When the driving speed reaches or exceeds the set value, a warning of over speed will appear on the combination instrument to show an alert to drive safely.

Theme settings

The theme style of the instrument can be set.

Driving data settings

You can set certain driving data on the multi-information display to be hidden or displayed. All data of the average fuel consumption, average vehicle speed, tripmeter and journey time can be cleared.

Alarm volume

You can set the alarm volume.

Unit settings

You can set the unit of the mileage & fuel, the pressure, and the temperature.

Language settings

You can set the display language of the combination instrument.

Reset to factory

Part of the menu settings of the combination instrument can be restored to the factory default state.

Maintenance miles

You can check the mileage to the next maintenance.

This information is only used to remind you to maintain your vehicle in time.

Indicator lights on the instrument

Vehicle equipment

Please note that this manual contains all the standard equipment, country-specific equipment and special equipment for this model series. Thus, some equipment or features described in this manual may not be installed onto your vehicle or are only available in some markets. For further configuration information, please refer to relevant sales information or consult with your distributor selling the vehicle to you.

Indicator lights on the instrument

NOTICE

- › When the power supply is switched ON, some indicator lights or warning lights will illuminate for a short time, indicating that the system self-test is in progress, which is normal. Depending on the model configuration, not all indicator lights or warning lights on the instrument cluster will illuminate.



Primary alarm indicator light

When this light goes on, an important alarm is currently present in the vehicle and at least one important alarm is manually shielded.

WARNING

Do not ignore any alarm. Otherwise, serious damage to the vehicle or an accident may be caused.

NOTICE

All current alarms of the vehicle can be checked on the alarm interface of the instrument panel.



Secondary alarm indicator light

When this light goes on, a secondary alarm is currently present in the vehicle.

WARNING

Do not ignore any alarm. Otherwise, serious damage to the vehicle or an accident may be caused.

NOTICE

- › The secondary alarm will be automatically shielded after being displayed on the multiinformation display of the instrument panel for a few seconds.
- › All current alarms of the vehicle can be checked on the alarm interface of the instrument panel.



Turn signal indicator lights

When the left turn signal lamp is on, the left turn signal indicator light will flash. When the right turn signal lamp is on, the right turn signal indicator light will flash. When the hazard warning light is on, the turn signal indicator light and all exterior turn signal lamps will flash together.

CAUTION

When the turn signal indicator light flashes quickly, it usually means that the turn signal lamp has been damaged. Replace it as soon as possible. Otherwise, other drivers on the road will not be able to see your turn signals.



Light on indicator light

When this light goes on, the main lighting switch is turned on.



Position indicator light

When this light goes on, position lamps and license plate lamps are on.



High beam indicator light

When this light goes on, the high beam headlamps are on.



Front fog lamp indicator light

When this light goes on, the front fog lamps are on.



Rear fog lamp indicator light

When this light goes on, the rear fog lamps are on.



Seat belt unfastened warning light

When this light goes on, the driver, the front passenger, or rear occupants are not wearing seat belts.



Door open warning light

When this light goes on, the door or the engine hood is open or not properly closed.



120km/h alarm indicator light

When this light goes on, the vehicle speed is over 120 km/h.



Airbag fault warning light

When this light goes on, the airbag system is malfunctioning. In this case, go to the authorised service centre as soon as possible for inspection and repair.



Tyre pressure monitoring system warning light

When this light goes on, the tyre has low pressure or high temperature, which is accompanied by an audible warning. At this time, stop the vehicle for inspections and contact the authorised service centre.

When this light flashes for a period of time and then lights up, the tyre pressure monitoring system is malfunctioning, which is accompanied by several audible warnings.

WARNING

If this light is on, you should avoid sharp turns or emergency braking, and drive the vehicle to a safe place as soon as possible, and stop for inspection.

Driving a vehicle when the tyre pressure is too low or the tyre temperature is too high will increase the possibility of tyre failure, and may even cause serious damage to the vehicle or lead to an accident.



Parking brake indicator light

When this light goes on, the parking brake is applied. When this light flashes, the brake disc temperature is too high or the road slope is too large. In this case, there is a risk of vehicle rolling. Depress the brake pedal and stop the vehicle on a flat road as soon as possible.



Parking brake fault warning light

When this light goes on, the electric parking brake system is malfunctioning.



AVH (Automatic Vehicle Hold) indicator light

When this light is on and yellow, the automatic vehicle hold is turned on and in standby status.

When this light is on and green, the automatic vehicle hold is turned on and in working status.



Anti-lock brake system fault warning light

When this light goes on, the ABS is malfunctioning.

At this time, contact the authorised service centre.

When this light goes on, the vehicle can still be braked normally although the anti-lock function is not available.



Brake system fault warning light

When this light goes on, the brake fluid level is too low or there is a malfunction in the braking force distribution system.

In this case, immediately stop the vehicle in a safe spot and contact the authorised service centre. Otherwise, a serious accident may be caused.



Electronic stability control indicator light

When this light flashes, the ESP is in working status.

When this light goes on, the electronic stability control system fails.



Electronic stability control off indicator light

When this light goes on, the ESC is turned off.



Hill descent control indicator light

When this light goes on, the hill descent control system is activated and ready for use.

When this light flashes, the hill descent control system is working.



Electric power steering system failure warning light

When this light goes on and yellow, the steering assist effect is reduced, so more force is required to operate the steering wheel. If this light remains on after the vehicle is restarted or after a short running distance, go to the authorised service centre as soon as possible for inspection and repair.

When this light goes on and red, the electric power steering system is malfunctioning, and steering assistance is no longer working. In this case, park the vehicle in a safe place and turn off the vehicle, and then restart the vehicle within several minutes. If the indicator light remains on, go to the authorised service centre as soon as possible for inspection and repair.

⚠ WARNING

When this light goes on and red, the electric power steering system stops functioning. In such a situation, you need greater force to steer the vehicle. Go to an authorised service centre as soon as possible for service.



Water temperature warning light

When this light goes on, the water temperature of the engine cooling system is excessively high. In this case, stop the vehicle immediately for inspection and repair. Otherwise, the engine may be damaged.



Low fuel level warning light

When this light goes on, the fuel is insufficient.

On slopes or during turning, the light

may go on prematurely due to unstable due to unstable fuel levels inside the fuel tank.

⚠ CAUTION

Do not drive the vehicle when the remaining fuel level is extremely low. Otherwise, the emission control system and powertrain system may be damaged due to running out of the fuel.



Engine fault warning light

If the light goes on after the engine is started, the engine has a fault that affects emissions.

At this time, contact the authorised service centre.

i NOTICE

) Failure of some control systems of the vehicle (e. g. loss of communication signal of hybrid system or charging system, etc.) may also cause this warning light to illuminate. If this warning light goes on, stop at a safe place as soon as possible, switch the power mode to OFF mode, then restart the vehicle and check this warning light. If the warning light is still on, it is recommended to go to the authorised service centre for inspection as soon as possible. Please drive carefully and avoid high speed before identifying the malfunction.

If this indicator light illuminates frequently, it is recommended to go to the authorised service centre for inspection even if the light goes out after following the preceding steps.

) The fuel tank cap not being properly installed may also cause this light to illuminate.



Engine maintenance warning light

When this light goes on, the engine has a fault not related to the emission. At this time, contact the authorised service centre.



Engine oil pressure warning light

When this light goes on, the oil is insufficient. In this case, park the vehicle in a safe spot as soon as possible and shut down the engine. Otherwise, the engine parts may be seriously damaged. Check the oil level after a few minutes and add oil if necessary. If the oil level is normal and the light is still on, contact a authorised service centre.



Charging warning light

If the light goes on after the engine is started, there is a malfunction in the battery charging system. In this case, go to the authorised service centre as soon as possible for inspection and repair.



Automatic transmission overheat warning light

When this light goes on, the automatic transmission fluid temperature is too high (when the vehicle is started frequently on the ramp or when the accelerate pedal is fully stepped etc., this light may be on). At this point, park the vehicle in a safe location as soon as possible to run at an idle speed and apply the parking brake to cool the transmission. If the light stays on after the above handling, contact the authorised service centre.



Adaptive cruise control indicator light

When this light goes on and white, the adaptive cruise control function is turned on and in standby status. When this light goes on and green, the adaptive cruise control function is turned on and the cruising speed is set successfully.



Adaptive cruise control system fault warning light

When this light goes on, the adaptive cruise control system is faulty. In this case, do not use the adaptive cruise control function, and go to the authorised service centre as soon as possible for inspection and repair.



Intelligent cruise control indicator light

When this light goes on and white, the intelligent cruise control function is activated and ready for use.

When this light goes on and green, the intelligent cruise control function is activated and the cruising speed is set successfully.

When this light goes on and red, a fault in the intelligent cruise control assist system. In this case, do not use the intelligent cruise control function, and go to the authorised service centre as soon as possible for inspection and repair.



Rear side assist system warning light

When this light goes on and yellow, the sensor for the rear side assist system is blocked. In this case, check both the inside and outside of the rear bumper on both sides for any obstructions and clear them away.

When this light goes on and red, the rear side assist system is malfunctioning. In this case, do not use the rear side assist system, and go to the authorized service centre as soon as possible for inspection and repair.

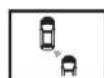

Doubling assistance indicator light

When this light goes on, the doubling assistance function is turned on.



Reverse side warning indicator light

When this light goes on, the reverse side warning function is enabled.



Lane departure indicator light

When this light goes on and green, the lane departure warning function is turned on. When this light goes on and red, the lane departure warning function is malfunctioning.

In this case, do not use this function, and go to the authorized service centre as soon as possible for inspection and repair.



Lane keep assist indicator light

When this light goes on and green, the lane keep assist function is turned on. When this light goes on and red, the lane keep assist function is malfunctioning.



Collision safety assist indicator light

When this light goes on and green, the collision safety assist function has been activated and is able to work normally. When this light goes on and red, something is wrong with the collision safety assist function. In this case, go to the authorized service centre as soon as possible for inspection and repair.

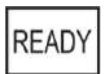

READY indicator light

When this light goes on, the vehicle is started and ready for normal driving.



EV indicator light

When this light goes on, the vehicle is only using electric power and the engine is not running.



Power reduction indicator Light

When this light goes on, the vehicle has a fault that affects the vehicle power output. At this time, the vehicle power is reduced and the speed will be limited.



Low power battery level indicator light

When this light goes on, the power battery is too low and must be charged soon.



Power battery fault warning light

When this light goes on and yellow, the power battery has a minor fault. When this light goes on and red, the power battery has a serious fault, and the power system will be powered off in an emergency.



Power system fault warning light

When this light goes on and yellow, the vehicle power system is malfunctioning.

In this case, immediately stop the vehicle in a safe spot and contact the authorised service centre. When this light goes on and red, the vehicle power system has a serious fault, and the vehicle cannot continue driving. At this time, contact the authorized service centre.



Motor malfunction warning light

When this light goes on, the drive motor system is malfunctioning. At this time, contact the authorised service centre.



E-Park fault indicator light

When this light goes on, the gear P controller is malfunctioning.



Brake energy recovery fault indicator light

When this light goes on, the braking energy recovery function is malfunctioning.

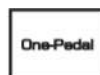

One pedal mode indicator light

When this light goes on, the one pedal mode is turned on.

Vehicle equipment

Please note that this manual contains all the standard equipment, country-specific equipment and special equipment for this model series. Thus, some equipment or features described in this manual may not be installed onto your vehicle or are only available in some markets. For further configuration information, please refer to relevant sales information or consult with your distributor selling the vehicle to you.

System introduction

The power management system can monitor the power consumption of each electrical equipment in the vehicle and allocate the power reasonably to improve the starting performance of the vehicle and extend the service life of the battery.

The power management system mainly has the following functions:

› Battery Monitoring

The current remaining power and health degree of the battery can be calculated accordingly as the voltage, current and temperature of the battery are continuously monitored by sensors.

› Sleep power management

Continuously monitor the power consumption of various electrical equipment during the parking period of the vehicle, and gradually shut down unnecessary electrical equipment according to the battery monitoring information, so as to avoid a large amount of battery discharge and ensure the starting performance of the vehicle.

› Static power management

Continuously monitor the power consumption of various electrical equipment when the vehicle is not started up, and gradually shut

down unnecessary electrical equipment according to the battery monitoring information, so as to avoid a large amount of battery discharge and ensure the starting performance of the vehicle.

› Dynamic Power Management

Continuously monitor the power consumption of each electrical equipment during the driving of the vehicle, and distribute the power generated by the generator to different electrical equipment as needed. When the generator generates more power than the demand of the electrical equipment, the dynamic power management system will regulate and supply power to the battery to allow it to reach the optimum charging status.

NOTICE

It is impossible for a power management system to go beyond the boundaries of physical law.

Please note that there are limits to the power and service life of the battery.

Information you should know

The power management system will give top priority to ensuring the starting performance of the vehicle.

In the event of short-distance traveling, and driving in urban areas and under low temperatures, the power consumption will increase, and the generator will supply less power. If the vehicle is not started, the use of electrical equipment will directly consume the power of the battery because the generator cannot supplement power in this case.

In these situations, the power management system will operate to control the power distribution.

Parking the vehicle for a long time

If the vehicle is not driven for several days or weeks, the power management system will gradually turn off the electrical equipment or reduce the electrical energy being used by the electrical equipment, so as to reduce power consumption and maintain the vehicle's starting performance for a longer time.

If the vehicle has been parked for a long time, certain convenient functions (such as remote unlocking, etc.) may not be available. After starting the vehicle, these functions will be restored.

When the engine is shut down.

For example, if you listen to the radio or use other functions of the audio/visual system with the engine off, the battery will discharge.

If the battery power consumption affects vehicle startup, a message will display on the multimedia display screen or the combination instrument. If you want to use these functions normally, please start the engine.

When the engine is running

During driving, even if the generator can provide electricity, the battery may lose power. This situation is prone to occur when the power consumption is too large and the generator provides less power, especially when the battery power capacity is low.

In order to restore necessary power supply, the system will temporarily shut down certain electrical equipment with high power consumption or reduce the power consumption of these equipment. Especially, the heating system consumes a considerable amount of energy. If it is found that the seat heating function is inoperative or the air volume of the air conditioning is limited, it means that the system has temporarily turned those functions off or adjusted them to operate at a lower power. When the power is sufficient again, these systems can be used normally again.

3

Audiovisual system

Safety prompt.....	138
Panel.....	139
Display screen.....	141
Interface introduction.....	142

Vehicle equipment

Please note that this manual contains all the standard equipment, country-specific equipment and special equipment for this model series. Thus, some equipment or features described in this manual may not be installed onto your vehicle or are only available in some markets. For further configuration information, please refer to relevant sales information or consult with your distributor selling the vehicle to you.

Safety

- › Ensure that your use of any of the system's features does not distract you and thereby interfere with safe driving. Your most important responsibility while driving is for the safety of the drive. You must obey all traffic regulations.
- › During driving, the driver is not allowed to operate the system and must keep the volume of the system at an appropriate level, so as not to affect driving safety due to lack of concentration.
- › This system may only be used in areas permitted by law. Some national or local regulations may prohibit use of the display screen within the driver's field of view.
- › Do not disassemble or modify the system.
- › When a failure occurs, stop using the system and contact authorised service centre. Do not try to repair the system by yourself.

About the use

- › For safety reasons, some functions may not be activated when the vehicle starts to move.
- › Do not press the buttons or knobs on the panel firmly.
- › Do not press the screen forcefully or scratch it with sharp objects.

- › When cleaning the display screen, do not use abrasive wipers or detergent containing organic solvent.
- › Do not strike the screen when image jitter occurs in process of operation.

About the radio

When driving the car, you may not find any radio stations, or you may hear noises or receive different radio signals with same frequency, depending on the environment such as road conditions, weather, etc.

About USB storage devices

Since there are various types of USB storage devices, this system may not be compatible with all USB storage devices.

About Bluetooth

- › Since there are a great number of smartphone brands with different functions, this system may not be compatible with all the smartphones.
- › If you cannot search and find the Bluetooth device name of this system during Bluetooth pairing, restart the Bluetooth on the smartphone and search it again.
- › If Bluetooth cannot be connected, delete the paired device on the smartphone, and pair it again.
- › If Bluetooth does not function properly when in use, disconnect the Bluetooth and reconnect it.

Vehicle equipment

Please note that this manual contains all the standard equipment, country-specific equipment and special equipment for this model series. Thus, some equipment or features described in this manual may not be installed onto your vehicle or are only available in some markets. For further configuration information, please refer to relevant sales information or consult with your distributor selling the vehicle to you.

Steering wheel buttons

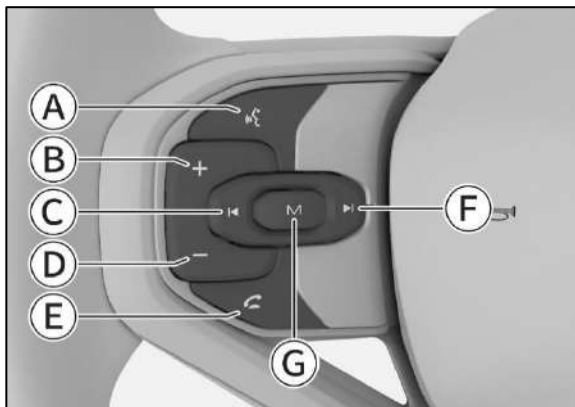

D6321AC3A6D5

- Ⓐ Voice button
- Ⓑ Volume+ button
- Ⓒ Previous track/radio button
- Ⓓ Volume- button
- Ⓔ Bluetooth phone button
- Ⓕ Next track/ radio button
- Ⓖ Media switching button

Voice button

After connecting and turning on Apple CarPlay or Android Auto, press the voice button  to activate the voice function.

i NOTICE

Depending on vehicle configuration, this function may not be provided for your vehicle. Please refer to the actual vehicle.

Media switching button

Press the [M] button to switch to media audio sources.

Bluetooth phone button

After connecting and activating Apple CarPlay or Android Auto, you can answer or hang up the phone via the Bluetooth phone button.

Power supply switch

Type I



51011A10EE18

- > Press the button to enter or exit the mute mode.
- > Press and hold the button (for more than 3 seconds) to enter the standby mode, touch the multimedia display, and exit the screen off mode.
- > Press and hold the button for more than 8 seconds to restart the multimedia system.

Type II



DC725A7EFA8

- › Press the button to enter or exit the mute mode.
- › Press and hold the button (for more than 3 seconds) to enter the standby mode, touch the multimedia display, and exit the screen off mode.
- › Press and hold the button for more than 8 seconds to restart the multimedia system.

External devices

USB interface



3E45280C9209

The interface with icon  can be inserted into U disk to play multimedia, and connected to mobile phone, etc.

The interface with icon  can be inserted into the U disk to play multimedia, and used to upgrade the system, etc.

i NOTICE

- › Due to different vehicle configurations, USB interfaces of some models may be installed in the hollow place on the right side of the auxiliary instrument panel. Please refer to the actual vehicle.
- › Ensure a stable connection between the external device and the input port.
- › Do not plug and unplug the device at will during playing to avoid problems such as the system not being able to recognize the device normally.

Media specifications

This system supports the following media specifications:

Media	Specification
USB device	USB devices with a partition format of FAT32/NTFS/ExFAT.
Bluetooth	Supports Bluetooth 4.2 (Bluetooth 4.2, compatible with 2.1 and 3.0, supports low power of Bluetooth), and supports Android Bluetooth protocol versions: A2DP 1.3, AVRCP 1.6, HFP 1.6, PBAP 1.2.

ประเภทไฟล์

ระบบนี้สนับสนุนประเภทไฟล์ดังต่อไปนี้

File	Format
Audio	MP3, WMA, AAC, AAC Plus, WAV, FLAC, APE, OGG
Video	MP4, MOV, 3GP, WMV/VC-1, AVI, MPG, MKV, WebM

i NOTICE

Even files in formats supported by this system may not be normally played due to file characteristics (such as file quality, bit rate, frame rate, resolution, compression quality, or corruption), playing environment and storage devices.





Display screen

Vehicle equipment

Please note that this manual contains all the standard equipment, country-specific equipment and special equipment for this model series. Thus, some equipment or features described in this manual may not be installed onto your vehicle or are only available in some markets. For further configuration information, please refer to relevant sales information or consult with your distributor selling the vehicle to you.

Display screen operation











You can complete functions such as selecting a target, scrolling the list, or moving an application by touching, sliding, and dragging on the central display screen.

Gesture	Operation	Result
	Tap	Select or enable a function
	Tap and drag	Scroll view or move between pages
	Tap with two fingers and expand	Zoom in
	Tap with two fingers and pinch	Zoom out

Display screen status bar

The status bar icons are displayed at the top of the central display screen to display the status of each function.

The status bar icons will change in real time according to functional characteristics, signal strength, connection status, switch status, etc.

Icon	Function status
	Time display
	Signal of the vehicle network is changed according to the network status
	WIFI is connected and the signal intensity can be displayed
	Mute mode on
	Sound mode on
	Bluetooth is not connected
	Bluetooth is connected
	USB device is connected
	Wireless charging not performed
	Wireless charging in progress
	Wireless charging completed

Interface introduction

Vehicle equipment

Please note that this manual contains all the standard equipment, country-specific equipment and special equipment for this model series. Thus, some equipment or features described in this manual may not be installed onto your vehicle or are only available in some markets. For the further configuration information, please refer to relevant sales information or consult with your distributor selling the vehicle to you.

Menu interface

i NOTICE

The screen display information (including images, icons, text and so on) shown in the manual is only for instructions. The information displayed may vary with the vehicle configuration, software version, themes and settings. Refer to the actual vehicle for specific information.

Type 1

In most interfaces, touch the menu button  to show the menu application interface.

The system enters the navigation system by default after power-up. In the other interface, touch the home button  to switch to the navigation interface.

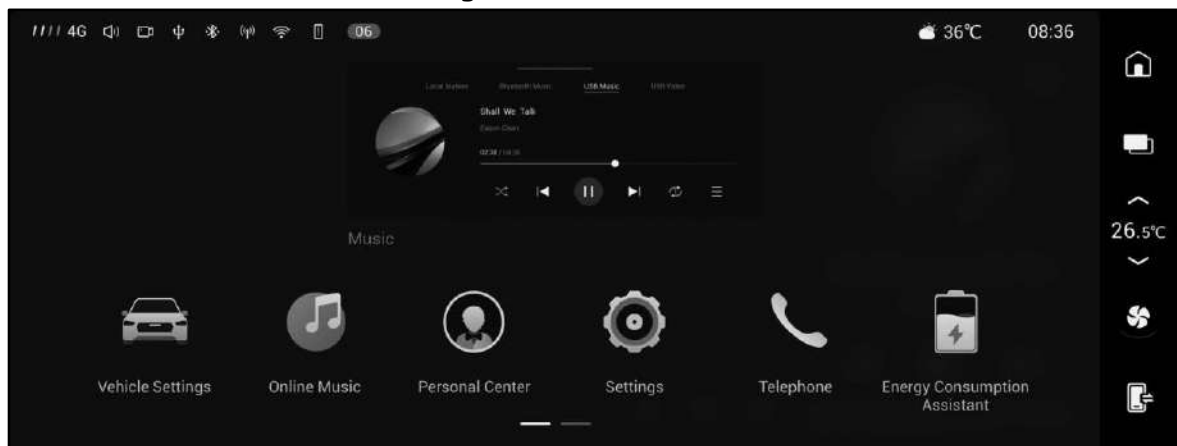

7D379FD3FF1B

The small windows of recently used applications are displayed on the top. Touch the small application window to quickly switch to the application interface.

The application icons are displayed at the bottom. Touch the application icon to switch to application interface.

Type II

In most interfaces, touch the menu button  to show the menu application interface.

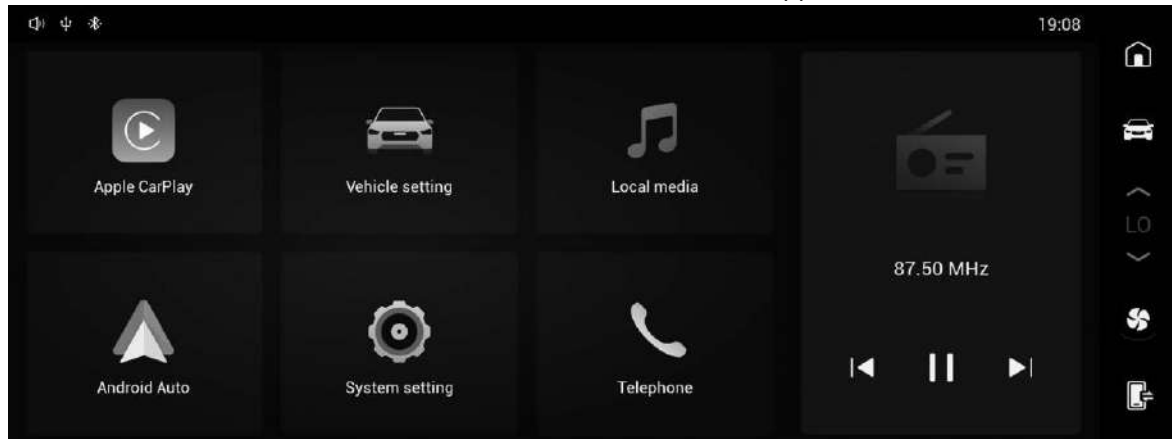

888DFD6DC66A

Vehicle Settings

Touch the [Vehicle Settings] button to switch to the vehicle settings interface where the function and switch states of the vehicle can be set.

System Setting

Touch the [System Setting] button to switch to the setting interface, where the Bluetooth, Internet, sound, display and so on can be set.

Telephone

Touch the [Telephone] button to switch to telephone interface. If other Bluetooth devices are not connected, go to the [System Setting] → [Bluetooth] interface to activate the Bluetooth for pairing and connection.

After pairing with other Bluetooth, functions such as dialling and answering calls, checking contacts, call records and SMS can be realized.

NOTICE

- > For pairing and connecting, please allow access to contacts, call records, messages and other permissions on the mobile phone. Otherwise, these functions cannot be used.
- > Message function is not supported by certain phones due to permission restrictions version systems.

i NOTICE

- › This communication device conforms to standards or technical requirements of NBTC.
- › The electromagnetic field intensity of this communication device conforms to Safety Standard for People to Use Communication Device Healthily published by National Telecommunications Commission.

Apple CarPlay

Connect the iPhone to the on-board USB1 (with the icon ) interface through the mobile phone USB data cable. Touch the [Apple CarPlay] button to switch to the Apple CarPlay interface. Disconnect the USB cable to exit from the Apple CarPlay.

i NOTICE

- › Due to the different compatibilities of mobile phone systems and versions, some iPhones may not support the Apple CarPlay function.
- › When an Apple CarPlay device is connected, the Bluetooth phone function is disabled, and the Apple CarPlay phone function can be used at this time.

Android Auto

Connect the Android phone to the on-board USB1 (with the  icon) interface through the phone USB data cable. Touch the [Android Auto] button to switch to the Android Auto interface. Disconnect the USB cable to exit Android Auto.

i NOTICE

- › If the Android Auto application is not installed on your Android phone, download it from the Google Play application store and install it on your phone.
- › Due to the different compatibilities of mobile phone systems and versions, some Android phones may not support the Android Auto function.
- › When an Android Auto device is connected, the Bluetooth phone function is disabled, and the Android Auto phone function can be used at this time.

Local Media

Touch [Local Media] to switch to local media interface which includes local radio, Bluetooth music, USB music and USB video.

Pair the system Bluetooth with other audio playback devices to play Bluetooth music on the [System Setting]→[WIFI] interface.

Insert the USB device which is used to store media documents into USB connector on vehicle to play USB music and USB video.

Personal Center

Touch [Personal Center] button to switch to the system setting interface, where you can log into the account, set account information, switch account and so on.

Message Center

Touch the [Message Center] button to switch to message center interface where you can check related messages.

Online Music

Touch the [Online Music] button to switch to online multimedia interface where search or select favorite media after connected to the network.

Energy Consumption Assistant

Touch the [Energy Consumption Assistant] button to switch to consumption assistant interface where you can check consumption information, driving suggestions and related settings.

Shortcut panel

In most interfaces, sliding down from the top of the screen will call up the shortcut panel.

Type I

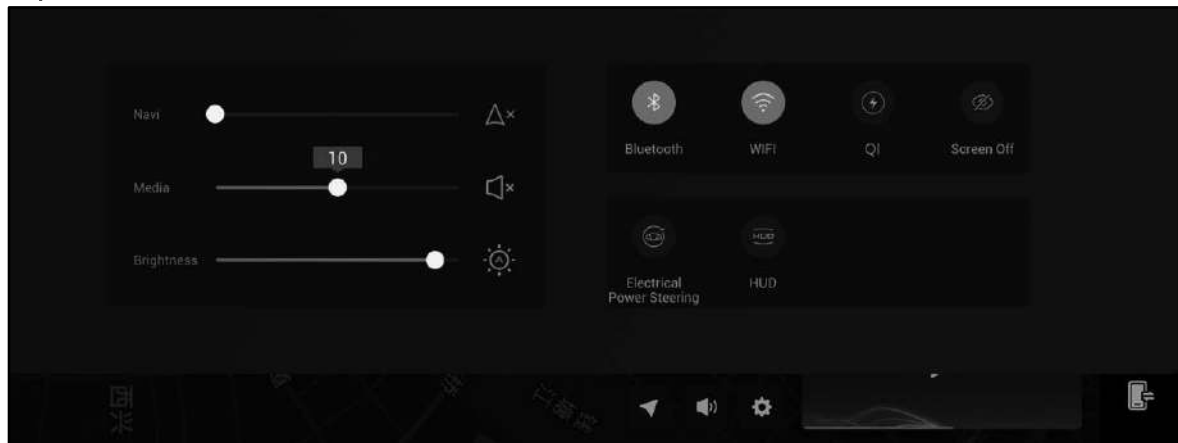

0309A6F3632A

Type II

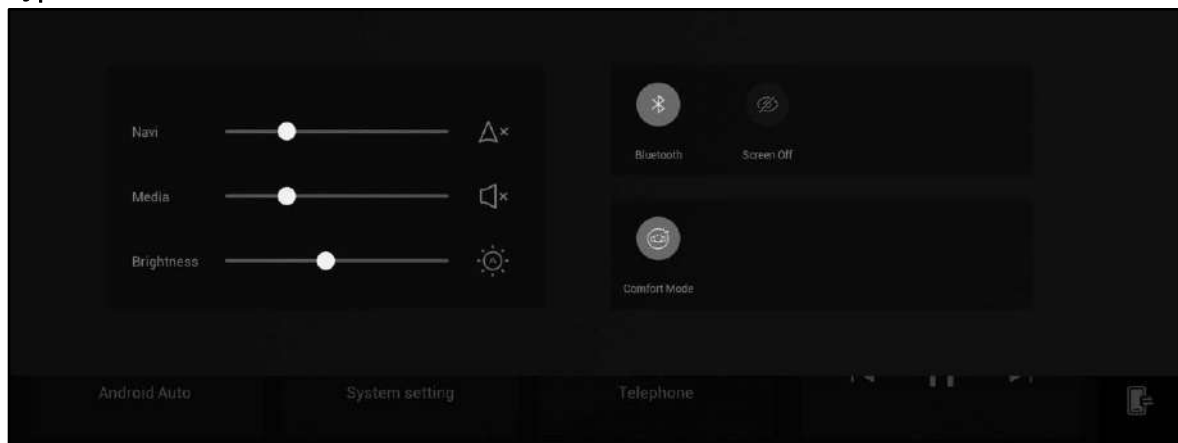

86D88E11CE10

Volume/brightness adjustment

Touch and drag the slider to adjust the corresponding volume or brightness

Touch the mute button  to enable or disable the navigation mute function.

Touch the button  to activate or deactivate the mute function of the media.

Touch the button  to activate or deactivate the automatic brightness adjustment function.

Shortcut switch

Touch the switch directly to execute, switch to, turn on or turn off the corresponding function.

You can edit and replace the shortcut switch displayed.

Interconnection



System description

The system can ensure the sharing of mobile phone applications with the on-board multimedia host, mainly including navigation, music, talkback, phone calls, voice recognition, etc. This can ensure you have a safer and more convenient vehicle experience.

NOTICE

- › Some mobile phone system versions may not support the interconnection function.
- › Due to the different systems and version compatibility, even the system version that is supported by the mobile phone may not support the interconnection.

Connection method

1. Download and install the APP on the mobile phone, open the APP, and enter the driving mode.
2. Connect the mobile phone with the on-board USBI(with the  icon) interface through the USB data cable.
3. Touch the button  on the multimedia display screen, and activate the interconnection by following the prompts. If the APP is not installed on the mobile phone, a QR code will be shown. You can scan the QR code with your mobile phone to download the APP.

NOTICE

- › Some mobile phones need to have USB debugging mode turned on for successful interconnection.
- › Some functions of interconnection (such as call function) are available only when mobile phone Bluetooth and car Bluetooth are successfully connected.
- › When mobile interconnection function of mobile phone is enabled, the screen of mobile phone will be dimmed to save the power of mobile phone.

Exit method

Disconnect the USB cable to exit the interconnection.

NOTICE

- › To achieve a better customer experience, the application will be constantly updated.
- › Some functions require information that is obtained from the Internet, and data traffic may occur in this process.

i NOTICE

- › This communication device conforms to standards or technical requirements of NBTC.
- › The electromagnetic field intensity of this communication device conforms to Safety Standard for People to Use Communication Device Healthily published by National Telecommunications Commission.

System Setting

In the menu interface, touch the [System Setting] button to switch to the system setting interface.

Bluetooth

Type I

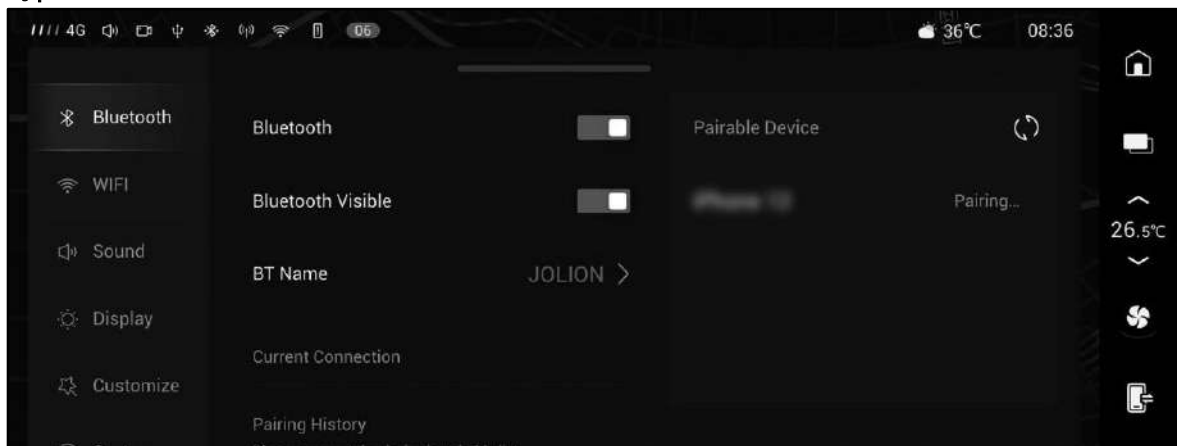

79E9E13CE8A5

Type II

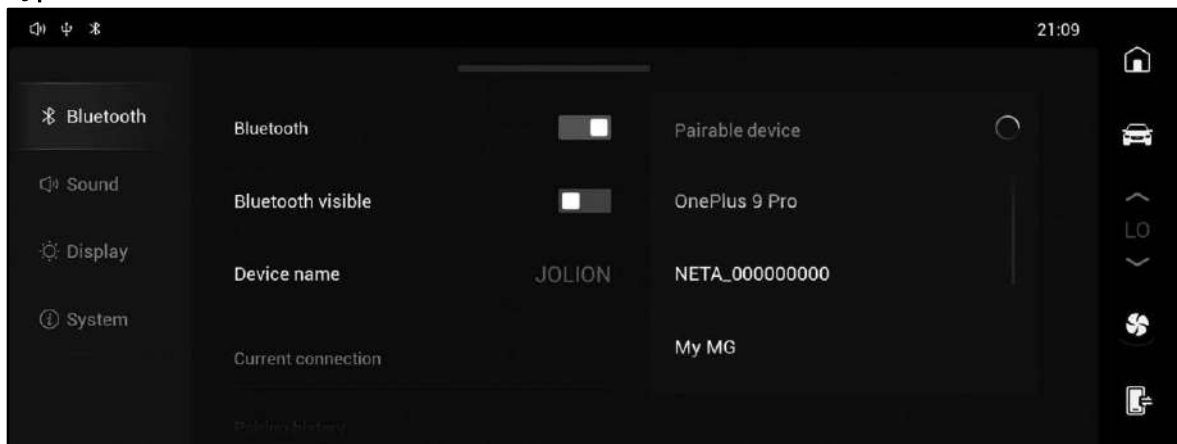

9BF072464DEB

- › [Bluetooth]: touch the Bluetooth switch of this system to turn on or off the Bluetooth.
- › [Bluetooth Visible]: after this switch is turned on, other devices are allowed to detect the Bluetooth of this system and perform pairing connection.
- › [BT Name]: it displays the name of the Bluetooth device, which can be modified to a custom name.

- › [Device Name]: it displays the name of the Bluetooth device.
- › [Pairing History]: it can display other Bluetooth devices currently connected, and you can disconnect or delete the paired device.
- › [Pairable Device]: it displays the Bluetooth devices searched for. Touch the name of the Bluetooth device you searched for to initiate a pairing request. Touch the [Search] button to search for Bluetooth devices again.

i NOTICE

- › This communication device conforms to standards or technical requirements of NBTC.
- › The electromagnetic field intensity of this communication device conforms to Safety Standard for People to Use Communication Device Healthily published by National Telecommunications Commission

WIFI

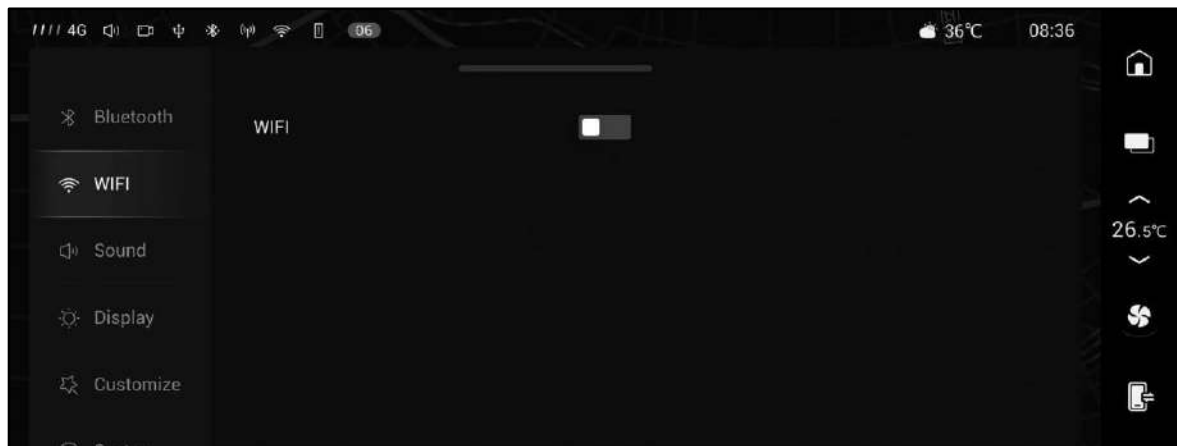

9A0EA3E7CBFE

- › [WIFI]: touch the WIFI switch of this system to turn on or turn off the WIFI.
- › [Networks]: after WIFI is turned on, you can display searched available network, and touch the network name in the list to connect.
With connected normally, this network can be displayed at [Connected], and touch [Disconnect] to disconnect current network.

i NOTICE

- › This communication device conforms to standards or technical requirements of NBTC.
- › The electromagnetic field intensity of this communication device conforms to Safety Standard for People to Use Communication Device Healthily published by National Telecommunications Commission.

Sound

Type I

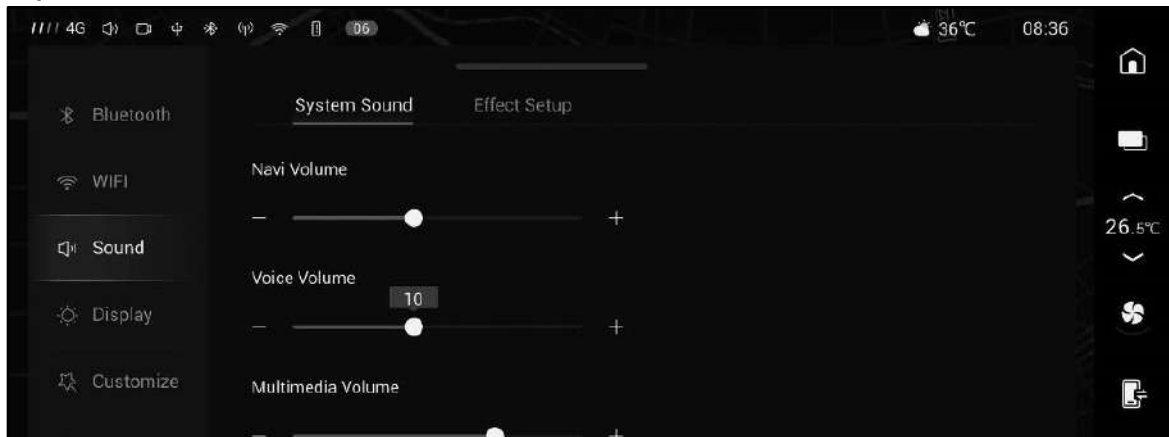

2D89A9391E20

Type II

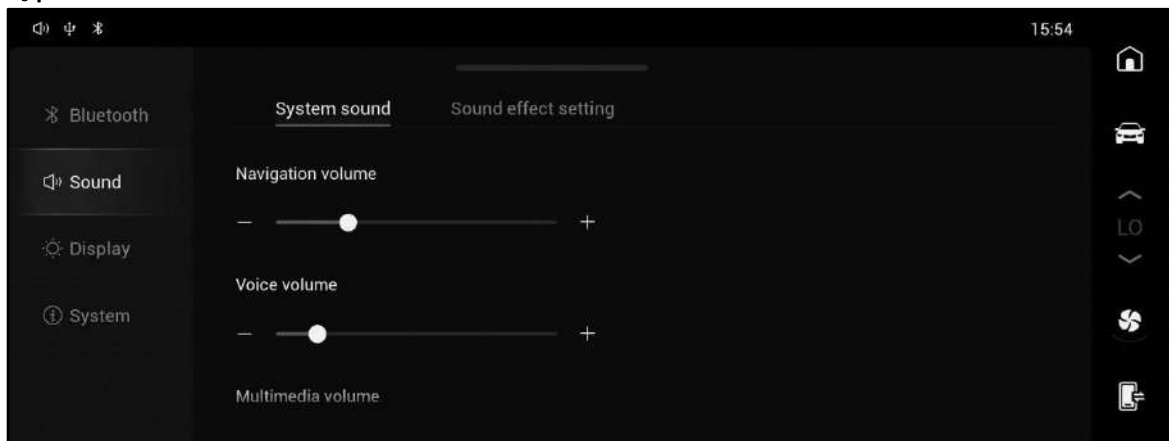

CD355506E718

- > [System Sound] : the navigation prompt sound, voice volume, media volume, call volume, vehicle alarm sound, speed sound compensation and so on.
- > [Effect Setup] / [Sound effect Setting]: you can set the DTS sound effect, the equalizer, the sound field and so on.

Display

Type I

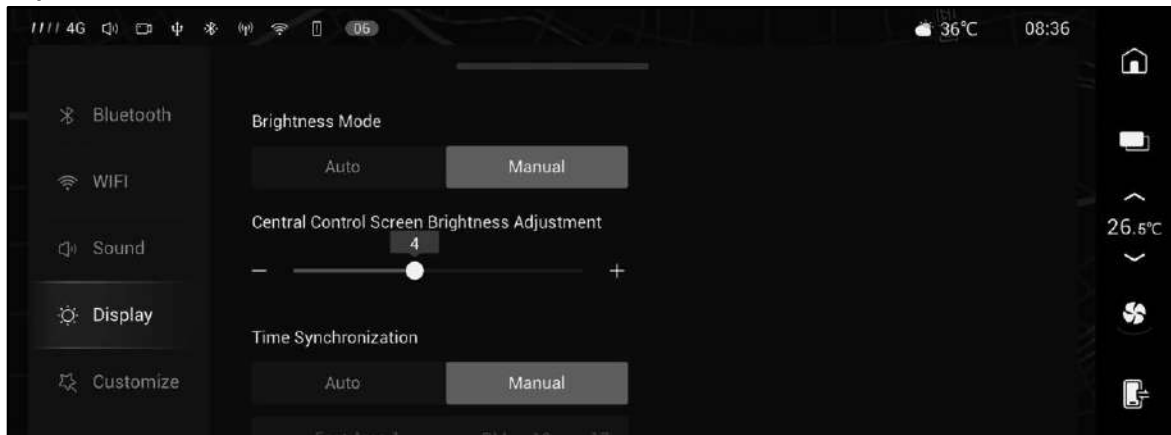

78D2B143E52B

Type II

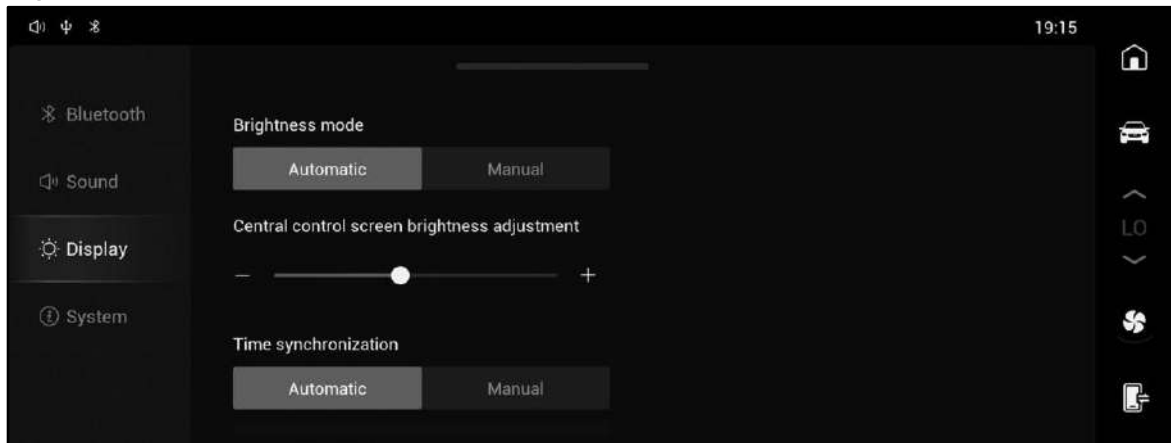

F156BCB44039

The brightness mode, centre-controller brightness, time display format, driving video limit, language, unit setting and so on can be set.

Customize

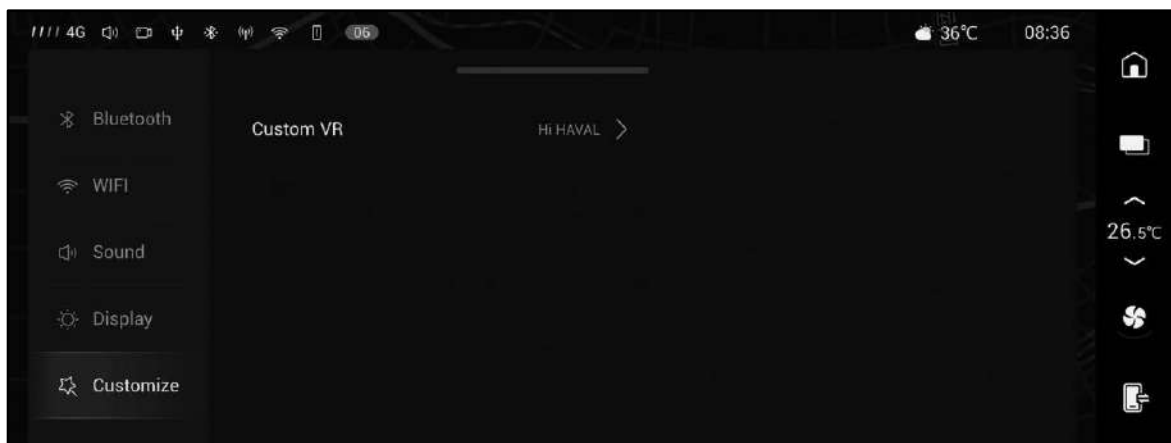

54B94F1A156F

The wake-up words of voice assistant can be set.

System

Type I

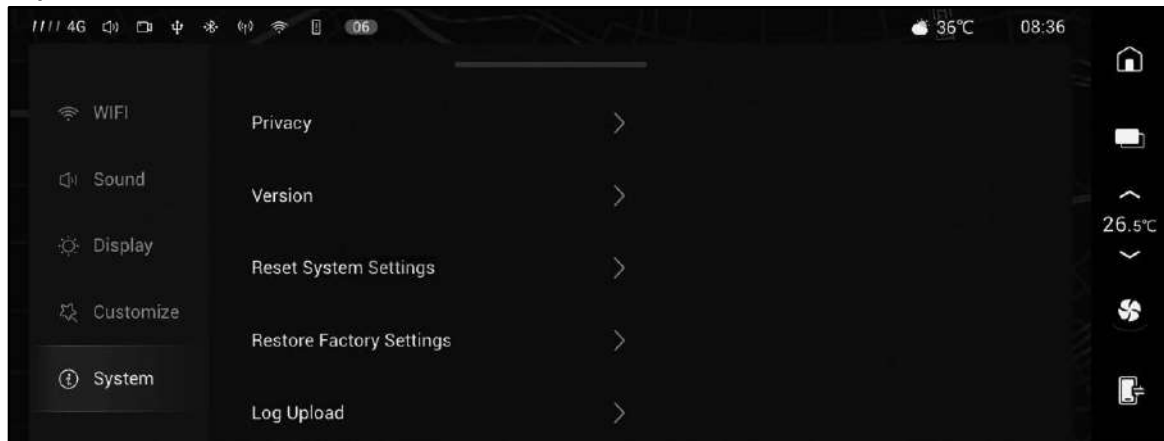

006B8315E470

Type II

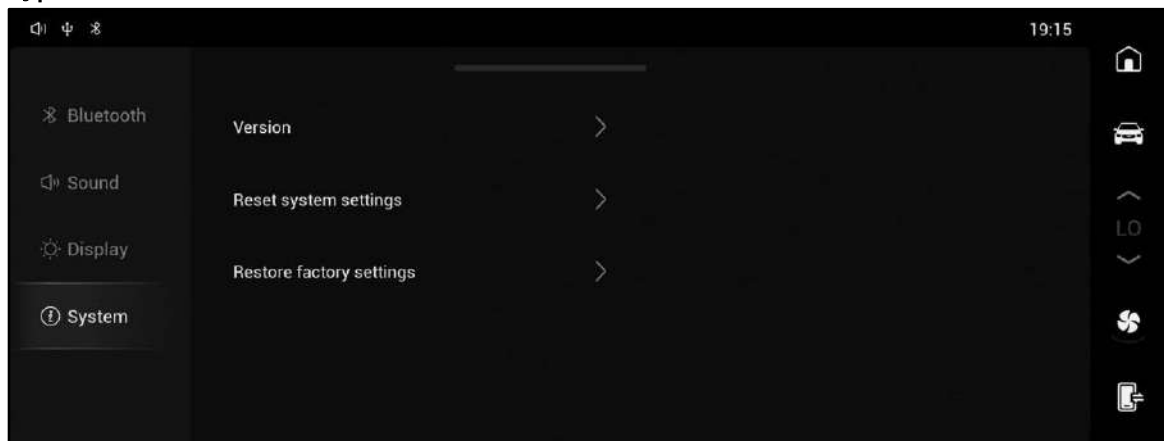

435643A07DAD

- > [Privacy]: the system can collect and store personal and vehicle data for providing
- > better vehicle network service. It can be turned on or off optionally.
- > [Version]: you can view and modify the name of this device, view the software version, update the system through WIFI/4G check and update, and update and update through the USB device.

i NOTICE

Depending on the vehicle configurations, some features may not be fitted to your vehicle. Please refer to the actual vehicle.

- > [Reset System Settings]: the system settings can be reset.
- > [Restore Factory Settings]: the system can be restored to factory default state.
- > [Log Upload]: the log data can be uploaded.

i NOTICE

About upgrades:

- › To ensure safety during the upgrade process, place the vehicle in a safe environment.
- › For ensuring successful upgrade, please keep the ignition switch in ON mode (READY indicator light off), apply the parking brake, keep the vehicle in stationary status and shut down high-power electrical appliances (such as A/C, lamps, speakers and so on).
- › During the update process, read the licence agreement on the download page and the precautions on the installation page carefully. To learn more about the update, click update details to view.
- › During the update process, all functions of the vehicle will be unavailable, including following situations: the vehicle cannot be started; the air conditioning cannot be used; the door cannot be opened and closed; the audio-visual entertainment function becomes invalid; all the fault indicator lights on the instrument panel will illuminate; the active and passive safety functions become invalid. Once the update is complete, however, all functions will be restored.
- › Do not change the vehicle state during installation (do not start the vehicle or shut down the system by force).
- › When updating via WIFI, please keep the network signal in good condition, and do not disconnect the current network connection during the update process.
- › During a host or screen update, a blank screen and system restart are normal. The host will restart in a few minutes, and the installation results will appear. Do not change the vehicle status during this time.
- › Please check the final result after the update is finished to ensure the vehicle is closed after all software is installed successfully. If the update failed or there are abnormal conditions during update progress, please contact the service provider.
- › After the upgrade is successful, the various updated system items, function, interface, operating methods, etc. may change, which is not as described in the manual.
The update information will be included in the interface prompt during upgrade progress.

Voice assistant

Voice assistant can recognize and execute voice commands to control vehicle functions quickly and improve operation convenience. There are several ways to activate the voice assistant:

- › Press the  voice button on the steering wheel.
- › Voice wake-up: you can perform this function via the system default wake-up words or customized words.

Check and set wake-up words at [System Setting] → [Customize] interface. (▷หน้า 148)

⚠ WARNING

When you control the vehicle using voice assistant, pay attention to the surroundings and personal safety to avoid pinch, collisions and other severe accidents.

Voice Command (when wake-up)

Voice assistant can recognize and execute voice commands to control vehicle functions quickly and improve operation convenience. Part of voice commands are listed in the following table, not all voice commands.

Category	Function	Command
Media	Radio	Turn on the AM stations, radio turn to FM 87.5, Turn on FM, and so on
	Online radio	Play online radio, following next online radio, and so on
	Online music	Switch on XXX APP, Play Rolling Stones song, Next song, and so on
	Local music (USB/ Bluetooth)	Switch to USB Music, Switch to Bluetooth Music, and so on
Bluetooth phone	Telephone	Help me calling 98654072155, Call XXX (Thai names in the address list), and so on
System	General	Select 1, YES, exit, next page, and so on
	Adjustment of volume	Volume up, Volume down, and so on
	Connection controller	Turn on bluetooth, Turn off bluetooth, and so on
Driving	Navigation	Take me to XXX, turn on real time traffic report, turn off real time traffic, and so on
	Around View Monitor (AVM)	Open AVM and so on
	Head up display	Close HUD, increase HUD brightness, and so on
Comfort	Air conditioning system	Switch on AC, set fan speed to level 1, car fan mode foot, open inner loop, activate cool mode, and so on
	Vehicle windows, sunroof	Open Sunroof, open the sunshade curtain, open driver window, close the window on passenger side and so on
	Seats	Turn on seat ventilation, set seat ventilation level 2, and so on
Weather	Weather forecast	How is the weather, how is the weather tomorrow, and so on
...

Voice Command (when not wake-up)

Some functions of the vehicle can be controlled by speaking commands without having to wake up the voice assistant

Category	Effective condition	Command
Multimedia	—	Previous music, Next music, Play music, Play radio, Stop playing, Pause, Previous music, Next music
System	—	Turn up volume; turn down volume; open settings
Air-conditioning	—	Turning on/off air conditioner
Telephone	—	Making a call
Turn on navigation	—	Open the map
Navigation	Navigate any frames	Go home, go to company
	Navigating and map is at the front desk	Stop navigation
	It can adjust map measuring scale	Map zoom out, map zoom in
	The view image of map can be adjusted	3D map, 2D vehicle head up, 2D north up
	Image of roads recognition	Begin navigation, the first road, the second road, the third road

NOTICE

- › Voice skill: navigation, music, video, telephone and other technologies, specific technical ability and frequently used commands are supported by voice assistant.
- › Please activate voice assistant and say “Help” to check these functions.
- › Adjustment of voice assistant volume: Adjust the volume via [System Setting] → [Sound]. (▷หน้าที่ 147)
- › The success rate of speech recognition will be affected by environmental noise, network signal, usage habits, pronunciation and other factors. The specific use effect is subject to the actual vehicle environment.
- › Using some functions of voice assistance require Internet access.

Navigation system

About navigation

- › It is recommended not to operate this navigation while driving the vehicle. Please operate under the premise of ensuring safety after parking to prevent traffic accidents or other dangerous situations.
- › The functions and service provided by this navigation is for reference only. Please do not take it as the only reference of driving or traveling. Please refer to the actual traffic and road conditions, and strictly abide by traffic laws and traffic rules.
- › Using services that require Internet access, such as online navigation, traffic conditions and data downloads, consumes network traffic.
- › Some online functions and services will not be available when the vehicle is not connected to the Internet and only uses offline navigation.

Enter the navigation interface

The system enters the navigation system by default after power-up. In the other interface touch  pages button to switch to the navigation interface.

Touch the non-button location on the map to call up the hiding function buttons.

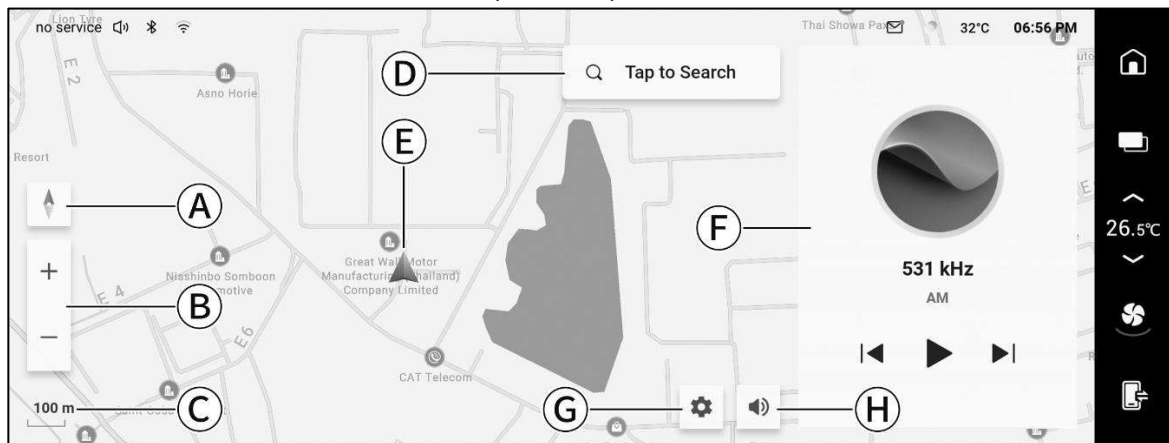

A82F7BEF8B35



- Ⓐ Map perspective
- Ⓑ Map zooming
- Ⓒ Map measuring scale
- Ⓓ Destination searching
- Ⓔ Self-vehicle position
- Ⓕ Audio playback window
- Ⓖ Navigation setting
- Ⓗ Navigation mute

Choose destination on map

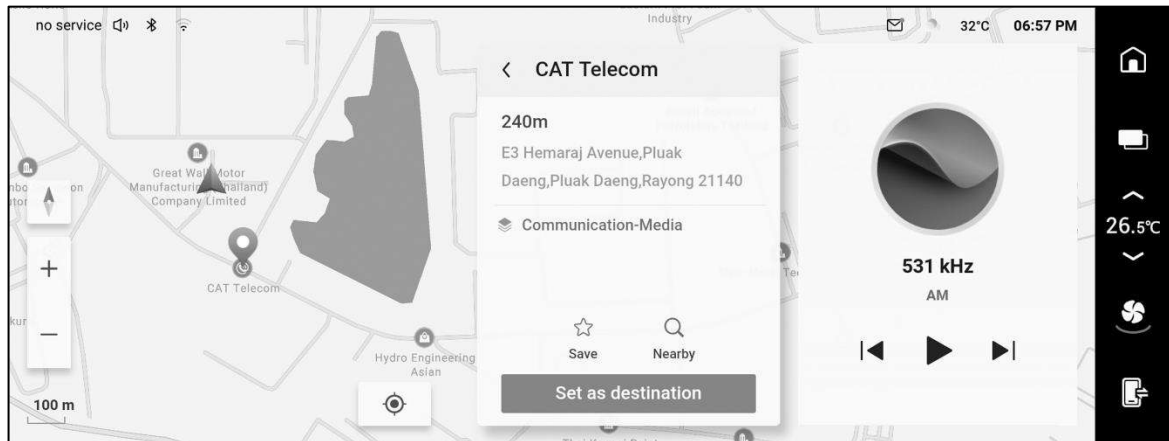
Touch the location for a long time on the map to switch to the location details interface.



A9175B0F1817

- › Tap  the back button to return to the previous interface.
- › Tap  the collection button to collect current place. Touch this button again to stop scanning.
- › Tap  surrounding search button to search surroundings.
- › Tap [Set as destination] button to set current place as destination.

Destination searching

Tap  the search button in the map interface to switch to the destination search interface.

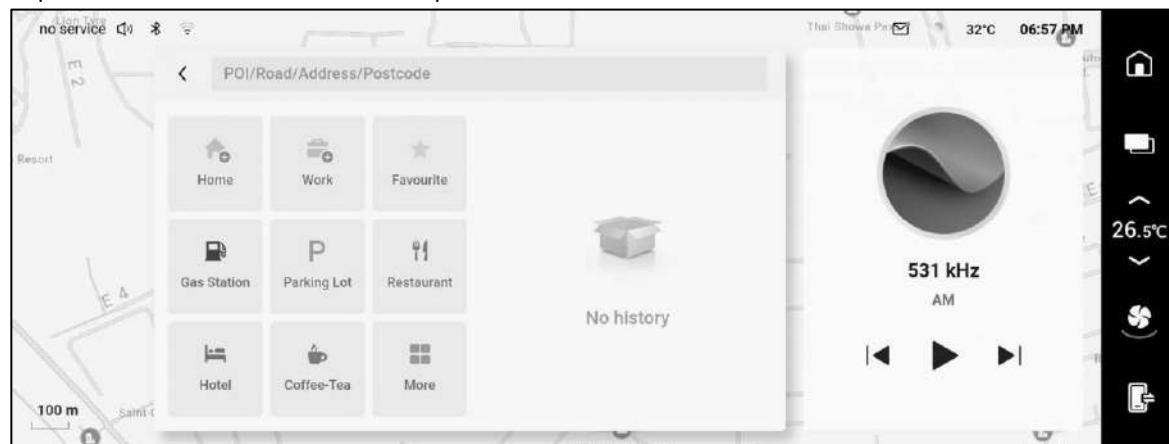

EF41EFA2B187

- › Tap [Home] button to set home address. After setting the home address, tap this button to set the location of home as the destination.
- › Tap [Work] button to set company address. After setting the company address, tap this button to set the location of company as the destination.
- › Tap [Favourite] button to switch to favourite interface and the favourite location. can be displayed. You can check, delete the favourite position and set it as destination.

Route plan

You can switch to route planning interface if you have set the destination through vary methods.

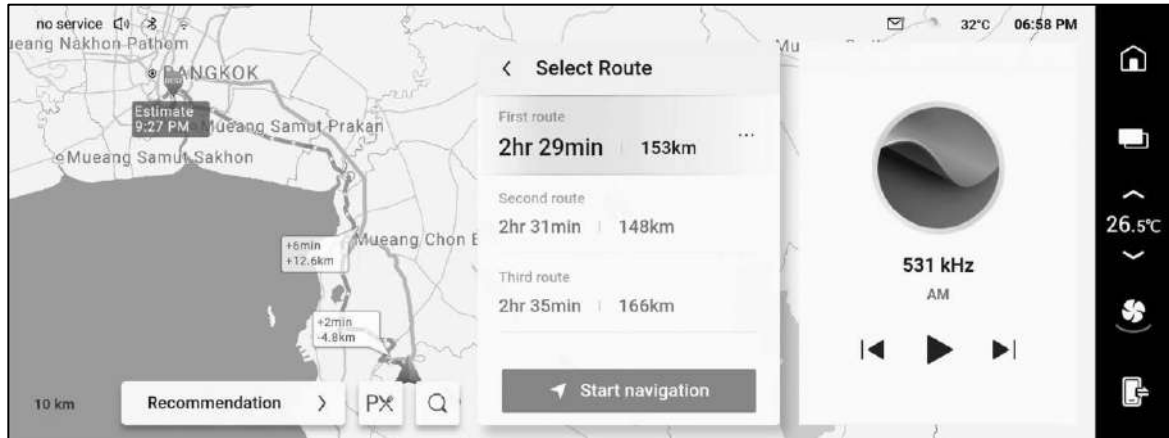

31C5BD107F21

- › Tap **⋮** the more button after route to switch route details. It can display the route name on current way according to the order from top to bottom.
- › Tap **Q** search button to switch to destination search interface to add way or change destination.
- › Tap **PX** service area button to display all service areas on current route.
- › Tap [Recommendation] button to display the menu of favourite routes and switch favorite routes.
- › Tap [Start navigation] button to switch to interface of route introduction and enter into navigation mode.

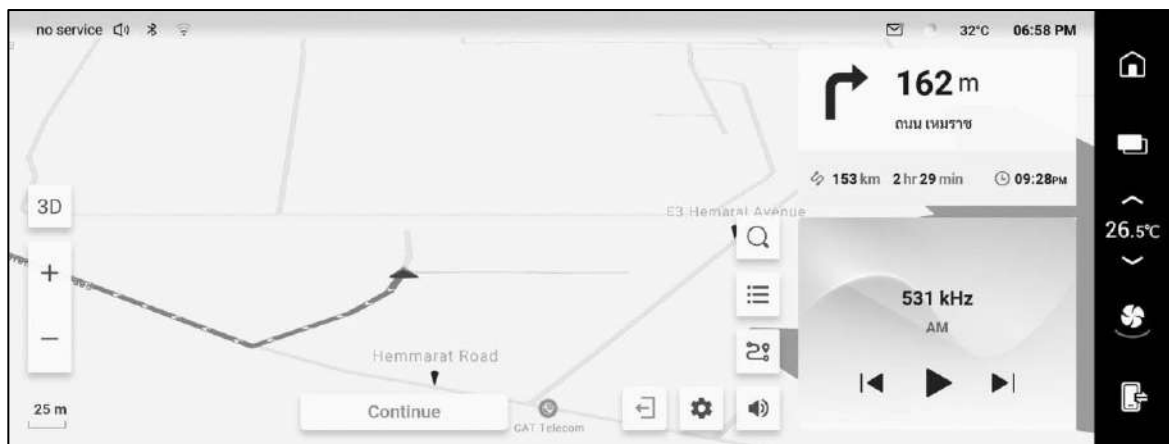

D6CEB5FFA49

Touch the non-button location on the map to call up the hiding function buttons.

Navigation setting

In the map interface  touch settings button to switch setting interface.

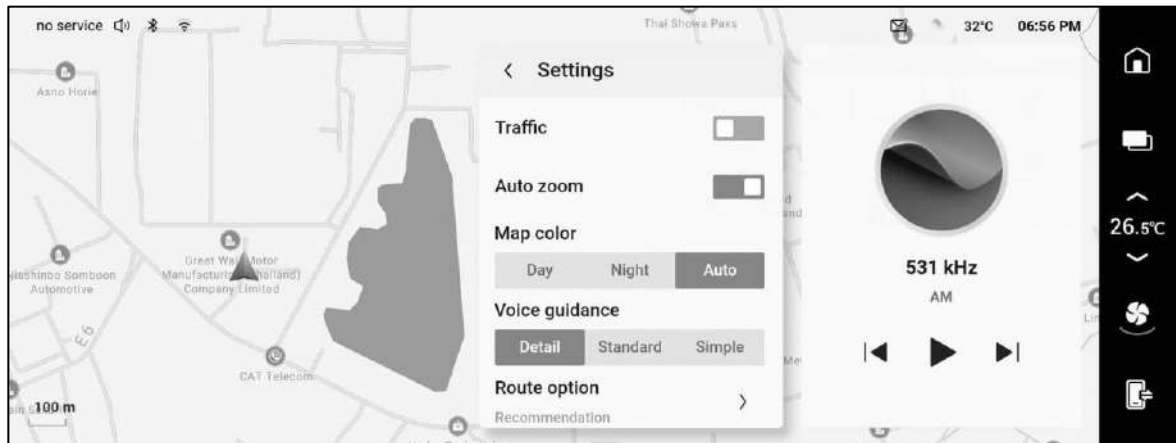

494C235443AD

You can set current road conditions, automatically proportional scale, map colour, navigation broadcast, favorite route, home/company address, delete personal information, online map update, USB map update and check version details and so on.

4

Safety

Seat belts 161
Airbags 164
Child restraint system 170
Vehicle anti-theft system 174
Emergency cut-off system 175
Event data recorder 176

Vehicle equipment

Please note that this manual contains all the standard equipment, country-specific equipment and special equipment for this model series. Thus, some equipment or features described in this manual may not be installed onto your vehicle or are only available in some markets. For further configuration information, please refer to relevant sales information or consult with your distributor selling the vehicle to you.

Safety tips

- › The shoulder belt must not hang on the neck area, or pass under the armpit area.
 - › The lap belt must be secured as firmly as possible around the lower part of the hip bone.
 - › Each seat belt can only be used by one person. More than one person (including children) must not share the same seat belt.
 - › If more than two people wear the same seat belt, when the vehicle is involved in a collision, not only the seat belt can not disperse the impact, but there is a danger of two people colliding with each other.
 - › The seat belt shall not be twisted or slack.
 - › Do not wrap the seat belt around objects with sharp corners, or it may be damaged during an accident.
 - › Never use a seat belt that has undergone strong impact from an accident or which is otherwise damaged.
 - › Do not remove, disassemble or alter seat belts.
 - › Do not use the seat belt with foreign object in the buckle.
 - › We suggest that when you use the seat belt, you shall keep your seat belt clean. Oil and water-based materials such as soil, oil stain, water, beverage, food residue, shall not be attached to the seat belt so as to ensure that it can be pulled out and retracted smoothly.
- › Do not use organic substances, such as benzene or gasoline, to clean the seat belts, and do not bleach or dye them.
 - › Children must not play with the seat belt. If a child accidentally wraps the seat belt around his or her neck while playing with the seat belt, he/she may not be able to pull the seat belt, resulting in serious injury or even death. In this case, if the locking tab of seat belt cannot be released, use a pair of scissors to cut the seat belt.
 - › Inside seat belt design is mainly based on adult size, so please install proper child restraint system for children. When the seat belt is being used correctly, if the belt is in contact with the child's neck or jaw area or slack to the hip, please switch to a child seat instead.
 - › If the child is old enough to use inside seat belt, he (she) shall wear the belt properly.
 - › Precautions for pregnant women We strongly suggest that you use the seat belt. You can also get effective advice by consulting with your doctor. The recommended way of wearing the seat belt for pregnant women is fundamentally the same as for other passengers. However, such passengers should take note of the following:
 - 1) The lap belt should be positioned as low as possible in the abdomen area, below the bulge of the belly.
 - 2) The shoulder belt should run over the passenger's shoulder, over the chest area but avoid the passenger's abdomen area.If the seat belt is worn incorrectly, during emergency braking or collisions, the seat belt may tighten over the abdomen area, causing injury or even death to the pregnant mother and unborn child.
 - › We strongly recommend that passengers who are ill or disabled use the seat belt. You can also get effective advice by consulting with your doctor.

- › When the seat belt is not in use, the it shall be fully retracted. Do not twist or jam the seat belt, and do not allow the seat belt to touch any sharp objects. The seat belt buckle cannot be blocked by foreign objects. Otherwise, correct engagement of the seat belt locking tab and the buckle will be affected.

Wear the seat belt properly

- › Adjust seat backrest until it is vertical or near-vertical and provides adequate back support.
- › The seat belt shall be neat.
- › The shoulder belt should lie flat on the centre of the shoulder and not on the neck or elsewhere away from the shoulder.
- › The lap belt should be, as much as possible, fastened around the lower part of the hip bone.

WARNING

- › During the drive, all passengers must fasten their seat belts in the correct fashion. Failure to do so can lead to severe injury or even death from collisions or emergency braking as passengers' bodies are not sufficiently bound to seats.
- › At any time, even the driving distance is short, all the passengers and the driver in the vehicle should wear seat belts properly. Otherwise, if an accident occurs, the risk of injury or death can be increased.

Pretensioner seat belt

Both driver's seat and front passenger's seat are equipped with pretensioner seat belt.

When a collision occurs, the pretensioner can retract the seat belt in an instant to secure the passenger to the seat as much as possible. The force limiter can maintain seat belt load at an acceptable level and reduce force exerted on the passenger's chest.

Operating conditions

The pretensioner seat belt works when the vehicle receives a significant impact from the front. It may not work when the following mild impacts occur:

- › When the vehicle hits a concrete wall square at a speed below 25 km/h.
- › When the vehicle collides with an object with a small surface area, such as a fixed electrical pole or tree, at a speed lower than 35 km/h.
- › The pretensioner seat belt may not fully function when the vehicle is subjected to the following severe collision.
- › The vehicle flips over by 90° or 180°.
- › When the impact comes from the side or rear of the vehicle.

WARNING

- › When using the pretensioner seat belt, please adjust the seat to the optimal driving position. Otherwise, the pretensioner seat belt may not work properly, which could cause serious injury or even death.
- › If you wish to install, remove or dismantle the pretensioner seat belt, be sure to contact authorised service centre.
- › If the pretensioner seat belt is not used correctly, it will not work as normal. It may cause severe injury or even death in an accident.
- › The pretensioner seat belt cannot be inflated repeatedly.
- › After the pretensioner has been inflated during the first collision, you should not extend or retract the seat belt again when the second and subsequent collisions occur. Be sure to contact authorised service centre for replacement.
- › When the pretensioner seat belt is inflated, there may be loud sounds and white smoke emanating from the device. This will not lead to a fire or cause harm to the human body.
- › When a pretensioner seat belt needs to be replaced and disposed of, be sure to contact authorised service centre

› Inadvertent/accidental movements of the pretensioner seat belt can cause harm to the human body.

How to use the three-point seat belt

1. Hold the locking tab and pull the seat belt out of the retractor. Make sure that you do not twist the seat belt in the process. If you are unable to pull the seat belt out of the retractor, you will need to first pull hard at the seat belt and then release it. Doing so will trigger the retractor and allow you to pull out the seat belt smoothly.
2. Insert the lock tongue into the buckle until you hear a "click" sound.

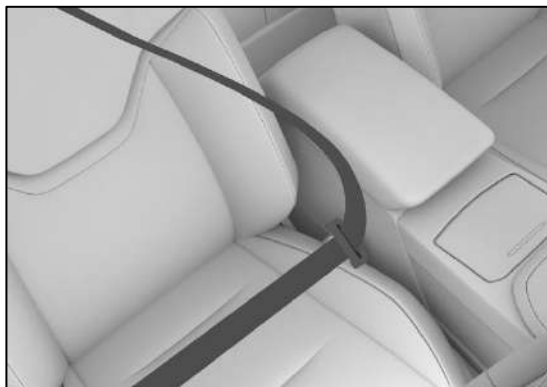

398F3716FB2E

3. Pull up the shoulder belt until the lap belt sits securely on the body. Thus, the pelvis is better secured and the risk of injury during moments of impact is reduced.
4. Check that the shoulder belt is sitting across the chest and on the center of the shoulder. Thus, any impact will be distributed across the upper skeleton.
5. Press unlock button on the buckle to retract seat belt. After the buckle has been released, hold on to the locking tab until the seat belt has been fully retracted. Take care that the locking tab does not knock into the passenger or any nearby objects.

Vehicle equipment

Please note that this manual contains all the standard equipment, country-specific equipment and special equipment for this model series. Thus, some equipment or features described in this manual may not be installed onto your vehicle or are only available in some markets. For the further configuration information, please refer to relevant sales information or consult with your distributor selling the vehicle to you.

Tips for safety

- › Airbags cannot be reused.
Once the airbag has been used, it will not work anymore in the second or subsequent collisions, so be sure to contact authorised service centre for replacement.
- › The airbag is an auxiliary device to protect the passenger safety and it shall be used with the seat belt. In order to obtain the effect of airbag, the passenger must wear the seat belt correctly and maintain the correct posture.
- › Only if the airbag is used properly, can it play its role and effect in full. If used improperly, it may not play a security role, but may bring harm to passengers.
- › When the airbag is being deployed you will notice some loud sounds and smoke.
- › This is normal and will not lead to a fire. The smoke released, however, may cause breathing difficulty when inhaled by individuals suffering from asthma or other respiratory disease. At this moment, it is safer to flee out of the vehicle immediately. If you are unable to evacuate from the vehicle, open vehicle doors or windows to let fresh air in.
- › When any debris (or gas) released by airbag deployment comes in contact with the eyes or skin, clean such material off using water as soon as possible. Otherwise, individuals with skin hypersensitivity may experience a skin reaction.
- › Do not touch airbag components after the airbag has been deployed. Because its component parts will become very hot, it may cause burns and other major injuries.
- › Please do not use the airbag for any other purposes.
- › Please get in touch with authorised service centre if you need to install radio equipment. Electromagnetic waves emitted by wireless equipment have a significant impact on the airbag control units.
- › It is forbidden to strike or squeeze the airbag and the position around it.
- › Avoid the condition that the airbag cannot work normally during accident or accidental deployment of the airbag in normal driving, which will cause serious injuries to passengers or even death.

Air bag

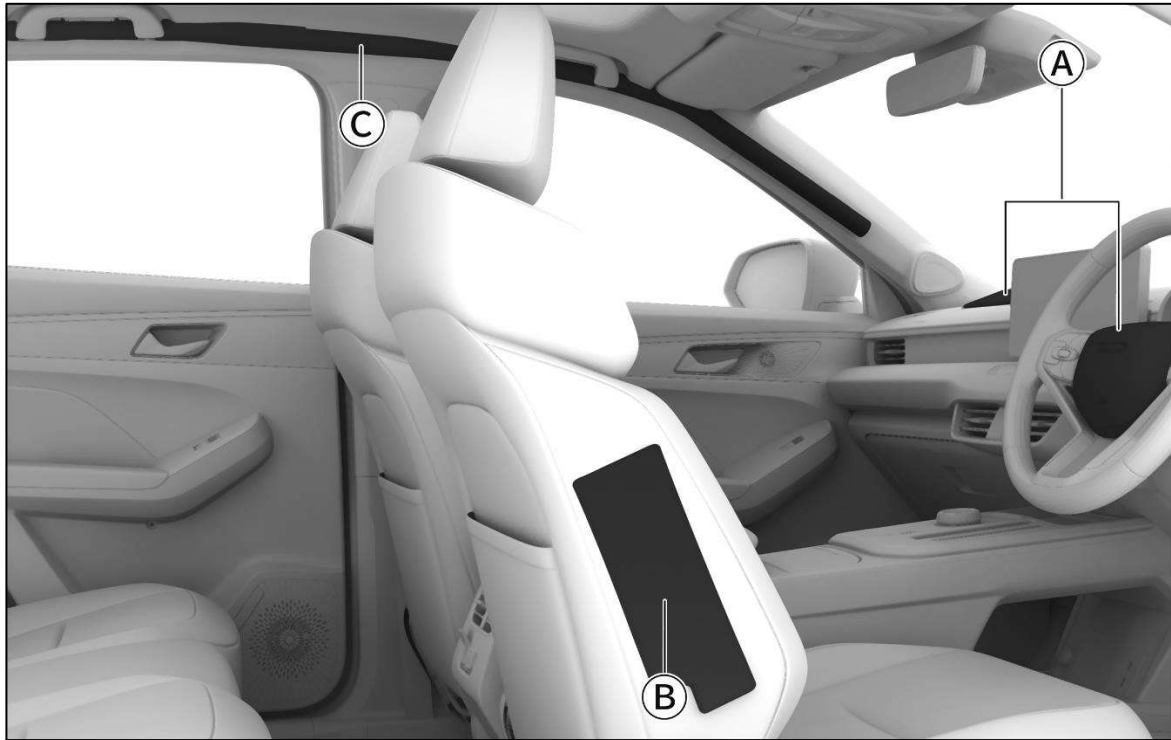

719409D33256

- (A) Front airbag, for:
 - Driver airbag
 - Front passenger airbag
- (B) Side airbag
- (C) Curtain airbags

Front airbags

Introduction

The front airbags are located in the steering wheel and the instrument panel which is in front of the front passenger seat, with the airbag logo on the steering wheel and instrument panel. When the vehicle encounters a strong front impact, the seat belt will be tightened. At the same time, the airbags at the driver's side and front passenger's side will deploy in order to distribute and cushion any force directed towards the head and chest.

Operating principle

When a head-on collision occurs resulting in moderate or severe impact, the sudden deceleration of the vehicle will be noted by a sensor. At this time, the control module will immediately deploy the airbag.

Precautions

- › The airbag may deploy when the bottom of the vehicle encounters the following kinds of severe impact :
 - 1) When the vehicle runs into the kerb.
 - 2) When the vehicle falls into, or runs over a deep pit or drain.
 - 3) When the vehicle climbs over the steps and hits or falls on the road.
- › The airbag may deploy when the vehicle rolls over 90° and 180°. However, it will not be able to function to its full capabilities.
- › The airbag may not deploy when the vehicle encounters the following kinds of severe impact:
 - 1) When the vehicle hits a concrete wall square at a speed below 25 km/h.
 - 2) When the vehicle collides with an object with a small surface area, such as a fixed electrical pole or tree, at a speed lower than 35 km/h.
- › If the object impacted changes shape or moves, the force from the collision will be reduced. At this point, the airbag may not deploy.

When the vehicle collides into a truck from the back, the vehicle will run under the cargo box. As the impact force recognized by the sensor is weak, the airbag may not deploy.
- › The airbag may also not deploy depending on the angle and direction of collision, even when vehicle speed is relatively high.
- › Please do not allow your body to get too close to the steering wheel or to the lower part of the instrument panel :
 - 1) When driving a vehicle normally, the driver shall stay away from the steering wheel as far as possible while maintaining the correct driving position.
 - 2) The front seats should be as far from the instrument panel as possible.
 - 3) All passengers should be belted up in the correct fashion for optimal protection.
- › Please do not sit on the edge of the seat or lean on the instrument panel while the vehicle is in motion.

Because the front airbag deploys at a high speed and with great force. If the passenger is too close to the airbag at this point, he or she may suffer severe injury or even death.
- › Please do not allow children to stand in front of the airbag.

When the front airbags deploys, it may cause severe injury or even death to child passengers. All children should be seated in the rear seats and be protected with the correct restraints.
- › Please adhere to the following rules, otherwise these items may cause severe injury to passengers during airbag deployment :
 - 1) Please do not place objects on the instrument panel or lean umbrellas, etc. on it.
 - 2) Please do not leave objects in the storage box exposed.

- 3) Please do not hang any objects on vehicle windows or on the inside rearview mirror.
 - 4) Please do not install any decorations on the steering wheel horn cover.
 - 5) Please do not place luggage, pets or other objects between the airbag and the driver or front passenger.
- › Please do not clean the inside of the vehicle with water or cleaning solution.
- The gas generator in airbag is a priming device. If it becomes damp, its normal operation will be affected or even cause serious injuries or death.
- › Please do not apply wax, stickers, or similar items to the airbag cover. Failure to adhere to the advice can impede airbag deployment.
 - › Do not damage airbag cover. Otherwise, it will not work normally. Therefore, be sure not to open or damage the airbag cover.
 - › Please do not dismantle, modify, or install equipment such as airbags, instrument panel and steering wheel. Improper operations can cause the airbag to malfunction or deploy by mistake, thereby causing severe injury or even death.
 - › Do not modify the suspension. If the vehicle height or suspension stiffness is changed, the airbag may deploy by accident and cause injuries or even death.
 - › Please consult with authorised service centre for assistance when you need to install a fender panel and baffle at the front of the vehicle. Modifications to the front of the vehicle can cause distortion to collision signals sent to the airbag sensor, thereby triggering accidental deployment of the airbag, which may cause serious injuries or even death.
- ›

- › Please be sure to consult with authorized service centre for assistance when you need to make repairs to the front of the vehicle or the front cab. Improper repairs can cause distortion to collision signals sent to the airbag sensor, thereby leading to airbag malfunctions, which may cause serious injuries or even death.

Front passenger airbag switch



43775C8A92E2

The front passenger side airbag switch is located on the side of the front passenger instrument panel.

Use a mechanical key to turn the front passenger airbag switch to OFF position to turn off the front passenger airbag. At this moment, the front passenger airbag OFF indicator  OFF on the reading lamp becomes illuminated.

Use a mechanical key to turn the front passenger airbag switch to ON position to turn on the front passenger front airbag.

At this moment, the front passenger airbag ON indicator  ON on the reading lamp becomes illuminated.

WARNING

- › Be sure not to place a rear-facing child seat on the front passenger seat while the front passenger airbag is operational. Otherwise, there will be a serious accident or even death.

› If, under special circumstances, it is necessary to install a rear-facing child seat on the front passenger seat, please turn off the front passenger airbag. Otherwise, there will be a serious accident or even death. In other conditions, you are advised not to turn the front passenger airbag lock to OFF, as the front passenger airbag would not be able to deploy if there was an accident.

Side airbags

Introduction

Side airbags are located inside the seat backrest outside liner, and airbag identification will be made on the seat backrest. Side airbags are the supplement of seat belt. In case of side collision, side airbags will reduce the damages to inside passenger and prevent subsequent collisions.

Operating principle

When the vehicle encounters impact from the side, the sensor will detect an acute change in vehicle speed and then send a signal to the control module. If airbag work condition is met, the side airbag will be deployed instantaneously. When a side collision occurs, only the side airbag of the side impacted will deploy. If the impact occurs on the front passenger's side of the vehicle, even if there is no one in that seat, the side airbag on front passenger's side will deploy all the same.

Precautions

- › The side airbag may not deploy when the vehicle encounters mild impact such as what is described below:
- 1) Front collision.
 - 2) Electronic control unit receives a weak signal of mild side impact.

- 3) Rear collision.
 - 4) Rollover.
- › Do not place any object over side airbags. Otherwise, it will disturb the normal work of the side airbag.
- › Never attach any object around the side airbag deployment area. Failure to adhere to this can cause such objects to dislodge when the side airbags deploy.
- › Do not remove, repair or modify seat with side airbag and parts around the side airbag deployment area.

Warning label



OC8DAAED6C78

The identification is located on the central pillar. It serves to remind you that the vehicle is equipped with side airbags and to pay attention to the relevant issues.

Curtain airbags

Introduction

The curtain airbags are located on the roof lower edge; you can find airbag marks on pillar. The curtain airbags are a supplement to seat belt. In case of side collision, curtain airbags will reduce the damages to interior passenger and prevent subsequent collisions.

Operating principle

In the event of a side collision, a sensor detects a sharp change in the lateral acceleration of



the vehicle and send a signal to the control module. If the curtain airbag work conditions are met, the curtain airbags on the collision side will instantly inflate.

Precautions

- › The curtain airbags may not inflate when the vehicle encounters mild impact such as what is described below:
 - 1) Front collision.
 - 2) Electronic control unit receives a weak signal of mild side impact.
 - 3) Rear collision.
 - 4) Rollover.

- › Please do not remain close to the vehicle doors, door pillars or roof rail, or kneel on a front seat. Otherwise, passengers' heads may suffer a severe impact when the curtain airbag inflates, which may cause serious injuries or even death. Pay attention especially when children are in the vehicle.
- › Never attach any object near where the curtain airbag will inflate. Otherwise, there is a risk that object may launch into the cabin when the curtain airbag inflates.
- › Do not hang heavy or sharp objects on the coat hook.
- › Please do not use clothes hangers if you wish to hang your clothing and opt for the coat hook directly instead. Otherwise, the clothes hangers may launch into the cabin when the curtain airbag inflates.
- › Do not remove, repair or modify parts near where the curtain airbag will inflate.
Do not modify roof, roof handrail, roof handrail bracket and side roof lamp.

Child restraint system

Vehicle equipment

Please note that this manual contains all the standard equipment, country-specific equipment and special equipment for this model series. Thus, some equipment or features described in this manual may not be installed onto your vehicle or are only available in some markets. For further configuration information, please refer to relevant sales information or consult with your distributor selling the vehicle to you.

Safety instructions for child seat

Warning label



90A96F30A2E6

This label, which is located on the front passenger side sun visor, is used to alert you that your vehicle is equipped with front airbag. Note the relevant precautions.

⚠ WARNING

Do not use rear-facing child restraint systems on the seats protected by front airbag (activated), which may cause the child suffering from death or serious injury.

- › If the child seat is not installed with child seat fixing device, use the seat belt to install it and then follow the installation instructions provided with the child seat.
- › Properly fasten the child seat inside the vehicle.

- › If you install the child seat incorrectly, in the event of emergency braking or accident, severe injury or even death may occur.
- › Do not place unsecured child seat protection devices in the vehicle.
If you leave it inside the vehicle, it may come into contact with passengers or other objects in the event of emergency braking or severe impact, causing a severe injury or even death.
- › Even when the child has sat in a child seat, take care that his or her head or body is not leaning against the vehicle door pillar or roof rail. When the curtain airbag fully deploys, it can be very dangerous in this scenario as the deployment force may cause severe injury or even death to the child.
- › Depending on the different types of child seat, when installing or removing a child seat, refer to the install instructions and precautions provided with the child seat.
- › Be sure to leave enough space around the child seat and adjust the seat in front if necessary.

⚠ WARNING

The following instructions must be followed for using a child seat on the front passenger seat.

- › **When installing a child seat on the front passenger seat, the front passenger airbag must be deactivated.**
- › **The front passenger airbag must be activated as soon as the child seat on the front passenger seat is removed.**
- › **If necessary, adjust the seat backrest angle until there is stable contact between the seat backrest and the child seat.**
- › **Take care that the seat belt is not twisted as it passes through the guide fitting and does not bend over the edge of the guide fitting**

- › For Group II and Group III child seats, ensure that the guide device mounted on the child seat headrest are in front of the seat belt anchorage point.

Fixing point for child seat

Lower fixing point of child seat

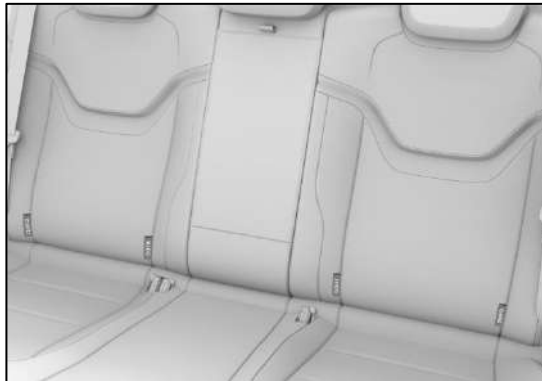

928DC87ABB4A

There are 4 fixing points on the lower part of the child seat in the clearance between the rear seat backrest and the seat cushion.

Top tether strap fixing point for child seat



865BFFDEF410

There are 2 fixing points for the child seat top tether strap on the rear side of rear seat backrest.

⚠ WARNING

Child restraint anchorages are designed to withstand only those loads imposed by correctly fitted child restraints. Under no circumstances are they to be used for adult seatbelts, harnesses, or for attaching other items or equipment to the vehicle.

Recommended child seat categories

ISOFIX is a mounting system for car child seats based on international standards.

In the user's country, child seats need to meet the ECE NO.44 specification. Only child seats that meet the above specification are allowed to be used in vehicles.

Weight group

Group	Weight (kg)	Age
O	Maximum 10	0-9 month(s)
O+	Maximum 13	0-2 year(s)
I	9 to 18	9 months to 4 years
II	15 to 25	4-7 years
III	22 to 36	6-12 years

Rear-facing child seat, quality group **O/O+**

Forward-facing child seat, quality group **I**

Cushioned child seat, quality group **II/III**

i NOTICE

For optimum protection, use the recommended child seat type, including rear and lap belt guides. Not every child is suitable for choosing a child seat in weight groups, and likewise not every child seat is suitable for your vehicle. It is therefore important to check that a child sits properly in the child seat and that the child seat is securely fastened in the vehicle.

Installation of child seat

When installing a child seat, you must use a child seat that is appropriate for the child's age, weight and physique to restrain an infant or a child in the seat.

Applicability information of child seat for different seat positions

Weight group	Seat position			
	Front passenger		Rear passenger	
	Front passenger airbag ON	Front passenger airbag OFF	Rear row external seat	Rear row centre seat
Group 0	X	U	U	X
Group 0+	X	U	U	X
Group I	X	U	U	X
Group II	X	U	U	X
Group III	X	U	U	X

Note: the letters filled in the above table are defined as follows:

U – this seat is suitable for universal child restraint system certified under this weight group.

X – this seat is not suitable for use with child restraint systems in this weight group.

If you need to install a rear-facing child seat on the front passenger seat, please pay attention to the following items:

- › Please be sure to turn off the front passenger airbag switch; otherwise, it will cause serious danger to children when the airbag deploys. (▷ page 164)
- › When installing a child seat on the front passenger seat, please adjust the front passenger seat as far back as possible.

Applicability information of vehicle ISOFIX positions for ISOFIX child seat

Weight group	Size model	Fixed module	ISOFIX position
			Rear row external seat
Portable bed	F	ISO/L1	X
	G	ISO/L2	X
Group 0	E	ISO/R1	IL
	Group 0+	E	ISO/R1
D		ISO/R2	IL
C		ISO/R3	IL
Group I	D	ISO/R2	IL
		ISO/R3	IL
	B	ISO/F2	IUF
	B1	ISO/F2X	IUF
	A	ISO/F3	IUF

Note: the letters filled in the above table are defined as follows:

IUF – this seat is suitable for general forward-facing ISOFIX child restraint system approved for the weight group.

IL – this seat is suitable for special ISOFIX child restraint system on the list. Such restraint systems may be special, restricted or semi-general.

X – ISOFIX position is not suitable for use with this weight group and/or ISOFIX child restraint system of this size.

Child seat installed with the seat belt

1. Move the front passenger seat as far forward as possible so that there is no contact between the front passenger seat and the child in the rear.
2. Adjust or remove the headrest of the seat where the child seat is installed; otherwise, the child seat may interfere with the headrest and can not be able to fit against the backrest.

3. Pull out the shoulder belt, move the belt along the indicated route on the child seat and insert the locking tab into the buckle until you hear a "click" sound.
4. With the body weight pressing down on the child seat, retract and tighten the shoulder belt to ensure no slack.
5. Shake the child seat gently to make sure that it has been properly secured.

⚠ CAUTION

If a booster seat is used, do not remove the headrest. Also, the top of the headrest should be adjusted to a position that is flush with or closest to the top of the child's head.

Child seats installed with the child

1. Move the front passenger seat as far forward as possible so that there is no contact between the front passenger seat and the child in the rear.
2. Adjust or remove the headrest of the seat where the child seat is installed; otherwise, the child seat may interfere with the headrest and can not be able to fit against the backrest.
3. Slide the child seat lock mechanism into the lower anchor point, and ensure that the two ISOFIX lock mechanisms are securely fixed.
4. When fixing the top tether strap, refer to the instruction manual of the child seat.
5. Shake the child seat gently to make sure that it has been properly secured.

⚠ CAUTION

If a booster seat is used, do not remove the headrest. Also, the top of the headrest should be adjusted to a position that is flush with or closest to the top of the child's head.

⚠ WARNING

- › If the child seat is equipped with a top tether strap, tighten the top tether strap according to the installation instructions and precautions provided with the child seat. Otherwise, severe injury or even death may be caused in the event of emergency braking or collision.
- › Do not lower the headrest after fastening the child seat top tether strap to its anchor point. Otherwise, it may come into contact with the top tether strap and loosen the strap as a result. In the event of emergency braking or collision, this can cause the child seat to turn, bringing severe injuries or even death.

Vehicle anti-theft system

Vehicle equipment

Please note that this manual contains all the standard equipment, country-specific equipment and special equipment for this model series. Thus, some equipment or features described in this manual may not be installed onto your vehicle or are only available in some markets. For further configuration information, please refer to relevant sales information or consult with your distributor selling the vehicle to you.

System introduction

The vehicle anti-theft system helps to keep your vehicle and valuables from being stolen. The vehicle anti-theft system will emit audible and visual alarm if someone tries to enter the vehicle by force.

WARNING

Do not attempt to modify the vehicle anti-theft system.

System activate

1. After the door is successfully locked by the button on the key, PEPS or the mechanical key, the turn signal lamp flashes once, and the vehicle enters the pre-arm mode. In pre-arm mode, you can still operate the vehicle without triggering the anti-theft alarm.
2. Once pre-arm mode has been activated for about 15 seconds, the vehicle will then be armed automatically and the anti-theft function is activated.

CAUTION

Please check whether all the vehicle doors and back door are completely closed. Otherwise, the vehicle anti-theft system cannot be activated.

NOTICE

The center control button will fail in the anti-theft state of the vehicle.

Alarm trigger condition

In an arm mode, the following actions may trigger an alarm:

- › Use the mechanical key to open the vehicle doors.
- › When a side door or the back door is forced open.

Alarm cancellation

After triggering the anti-theft alarm of the vehicle, the alarm can be cancelled by the following operations:

- › Switch power supply mode to ON mode.
- › Start the vehicle successfully.
- › When the power supply is in OFF mode, unlock the doors or the tailgate via the button on the key or the PEPS.

System off

The vehicle doors and back door are unlocked via the key button or the PEPS.

The turn signal lamp flashes twice and the anti-theft function of the vehicle is off.

Emergency cut-off system

Vehicle equipment

Please note that this manual contains all the standard equipment, country-specific equipment and special equipment for this model series. Thus, some equipment or features described in this manual may not be installed onto your vehicle or are only available in some markets. For further configuration information, please refer to relevant sales information or consult with your distributor selling the vehicle to you.

Emergency cut-off system

When the impact sensor detects a certain degree of impact, the system will cut off the high voltage current and fuel supply, and minimize the danger caused by electric shock and fuel leakage.

If the emergency cut-off system is activated, the vehicle cannot be restarted.

At this time, please contact authorized service centre.

Vehicle equipment

Please note that this manual contains all the standard equipment, country-specific equipment and special equipment for this model series. Thus, some equipment or features described in this manual may not be installed onto your vehicle or are only available in some markets. For further configuration information, please refer to relevant sales information or consult with your distributor selling the vehicle to you.

System introduction

The vehicle is equipped with the event data recorder (EDR).

The event data recorder (EDR) is mainly used to record data related to vehicle dynamic system and safety system when a vehicle collision happens in order to help understand the operation conditions of vehicle system. However, since collision severity and type vary, EDR may not record the data.

i NOTICE

EDR records data only when a vehicle meets a major collision. When the vehicle runs normally, EDR does not record data.

Data reading

Except the vehicle manufacturer, other parties (such as law enforcement agencies) can read the data recorded in EDR after connecting the laptop with the onboard diagnostic interface to enter the EDR by using CANoe equipment. The data reading equipment can be purchased from CANoe software vendors.

The data items recorded by EDR and their uses are as follows:

The data items recorded by EDR and their uses are as follows:

Data item	Applications
Braking state	Record the brake pedal status during collision
Speed during collision	Record the speed at the time of collision
Status of the seat belt lock body	Record the safety belt status during collision
Status of the airbag System warning lamp	Record whether the airbag failure warning lamp is on before collision

Data disclosure

Any data recorded by EDR will not be disclosed to third parties except in the following circumstances:

- › With the consent of the vehicle owner or lessee.
- › To be used in a lawsuit at the official request of the police, court, or government department.

However, if necessary, the data recorded by the EDR will be used to:

- › Research and develop the vehicle safety performance.
- › For R&D purpose, data is disclosed to the third parties without disclosing specific information about the owners and their vehicles.

5

Emergency

On-board toolkit	179
Emergency tyre repair and inflation	180
In case of an accident	182
Jump start	183
Engine overheating	185
Towing	186
Service and rescue	190

Vehicle equipment

Please note that this manual contains all the standard equipment, country-specific equipment and special equipment for this model series. Thus, some equipment or features described in this manual may not be installed onto your vehicle or are only available in some markets. For further configuration information, please refer to relevant sales information or consult with your distributor selling the vehicle to you.

Location of on-board toolkit

On-board document packages are placed in the storage box on the side of the front passenger, and other on-board tools are placed in the luggage area.

CAUTION

- › The driver must be familiar with the storage location and instructions of the on-board toolkit in order to cope with emergency.
- › And the driver must return the onboard toolkit to their designated positions after use, and fix them securely. Random placement may cause accidents.

Emergency tyre repair and inflation

Vehicle equipment

Please note that this manual contains all the standard equipment, country-specific equipment and special equipment for this model series. Thus, some equipment or features described in this manual may not be installed onto your vehicle or are only available in some markets. For further configuration information, please refer to relevant sales information or consult with your distributor selling the vehicle to you.

Inflator and tyre repair fluid

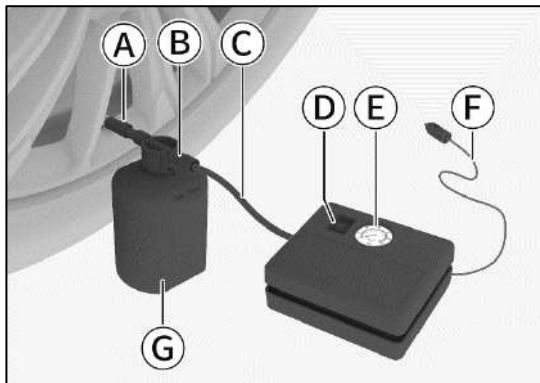

E61433C7A117

- (A) Outlet tube
- (B) Air inlet
- (C) Inflation tube
- (D) inflator switch
- (E) Barometer
- (F) Power cable
- (G) Tyre repair liquid

In case of tyre leak caused by puncture of foreign matters, emergency maintenance can be carried out with inflator and tyre repair fluid.

i NOTICE

- > The inflator and tyre repair fluid are only suitable for sealed tyres with puncture on the tread.

- > The tyre repair fluid has limited ability to seal the puncture of the tyre wall. If the tyre has large fissures, cracks or similar damage, tyre repair fluid shall not be used to seal the tyre.
- > The tyre repair fluid tank must be replaced after use. It is recommended that it be replaced by professionals from authorised service centre.

⚠ WARNING

- > If the tyre repair fluid has expired, please replace it and treat it as hazardous waste.
- > Eating the tyre repair fluid by mistake is harmful to health. It may cause allergic reaction even in the case of skin contact. In case of contact with skin, immediately wash the sealing liquid from skin with water or soapy water.
- > The tyre repair fluid must be stored out of reach of children.

Emergency tyre repair

1. If the tyre is repaired in a place where vehicles pass, please put a warning triangle at an appropriate position and turn on the hazard warning lamp.
If the tyre puncture is caused by nails or similar objects, leave the objects in the tyre. This helps to seal the puncture hole.
2. Shake the tyre repair liquid and use it evenly. Make sure that the inflator switch is off (in position "O"), and then take out the power cord and inflation tube.
3. Unscrew the cover of the tyre repair fluid inlet, connect the inflation tube to the tyre repair fluid inlet and tighten it, and connect the outlet tube of the tyre repair fluid to the tyre valve.

⚠ CAUTION

The inflation tube cannot be bent.

4. Plug the inflator power cord into the standby power outlet and start the vehicle.

5. Switch the inflater switch to the position "I" to start the inflater and inflate the tyre to 240~250 kPa.

⚠ WARNING

Do not stand beside the tyre when operating the inflater. If the tyre is cracked or uneven, the inflater must be turned off immediately.

⚠ CAUTION

- › When the inflater is turned on, the air pressure will be very high at first, then decrease slowly, and gradually increase with the inflation air pressure.
- › The inflater shall not run for more than 10 minutes; otherwise, there is a risk of overheating.
- › If the tyre pressure is still lower than 170 kPa after inflation, it means that the tyre has a large hole, so please do not continue to inflate it. At this time, you are suggested to contact authorized service centre.

6. Turn off the inflater, remove the power cord from the 12V outlet, and remove the tyre repair fluid from the tyre valve.
7. Drive immediately (within 1 minute) at a speed of 20~60 km/h for about 5 km, so that the tyre repair fluid can seal the tyre evenly.
8. Connect the inflater and read the tyre pressure on the pressure gauge.
 - › If the tyre pressure is lower than 170 kPa, it means that the tyre is not completely sealed. At this time, do not continue driving and contact authorised service centre.
 - › If the tyre pressure exceeds 170 kPa, the tyre shall be inflated to the pressure specified in the tyre pressure label.
9. Turn off the inflater, disconnect the inflation tube and the power cord, and install the dust cover of the tyre valve.

⚠ CAUTION

After the tyre is inflated, it is necessary to install the dust cover of the tyre valve to prevent the gravel and dust from damaging the tyre valve.

⚠ WARNING

After the tyre is repaired with inflater and tyre repair fluid, the driving speed shall not exceed 80 km/h and the driving distance shall not be more than 200 km. It is recommended that you repair or replace the damaged tyre as soon as possible, and inform the maintenance technician that the tyre contains tyre repair fluid.

Tyre inflation

When the tyre pressure is too low, you can use an inflater to inflate the tyre.

1. Make sure the inflater is turned off, and take out the power cord and inflation tube.
2. Screw the inflation tube into the tyre valve.
3. Plug the power cord into the standby power outlet and start the vehicle.
4. Turn the inflater switch to position "I" to start the inflater.

⚠ CAUTION

The inflater shall not run for more than 10 minutes; otherwise, there is a risk of overheating.

5. Inflate the tyre to the pressure specified in the tyre pressure label.
6. Turn off the inflater, disconnect the inflation tube and the power cord, and install the dust cover of the tyre valve.

In case of an accident

Vehicle equipment

Please note that this manual contains all the standard equipment, country-specific equipment and special equipment for this model series. Thus, some equipment or features described in this manual may not be installed onto your vehicle or are only available in some markets. For further configuration information, please refer to relevant sales information or consult with your distributor selling the vehicle to you.

Traffic accidents occur to vehicles

When the vehicle is forced to stop on road because of traffic accidents or vehicle failure, in order to warn other vehicles, please take the following measures:

- › Turn on the emergency flashers.
- › Please place the warning triangle behind your vehicle in accordance with local traffic laws and regulations.

Jump start

Vehicle equipment

Please note that this manual contains all the standard equipment, country-specific equipment and special equipment for this model series. Thus, some equipment or features described in this manual may not be installed onto your vehicle or are only available in some markets. For further configuration information, please refer to relevant sales information or consult with your distributor selling the vehicle to you.

Symptoms of a drained vehicle battery

- › The vehicle cannot be started.
- › Headlamps are darker than normal.
- › The horn cannot give a sound or the sound is weak.

How to jump start the vehicle

If you are unable to start the vehicle with depleted battery, you can jump to the battery of using another vehicle to start the vehicle.

⚠ CAUTION

- › **Not all the vehicle's batteries can be used for this. Jump start can only be performed with a battery having a rated voltage of 12 V.**
- › **You cannot start the vehicle by using a trolley or trailer.**

1. After removing the luggage area cover plate, open the battery plate.

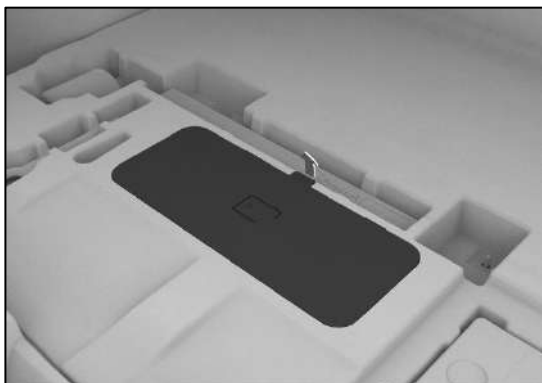

5DOF49A67D5E

2. Open the protective cover on the positive terminal of the battery.

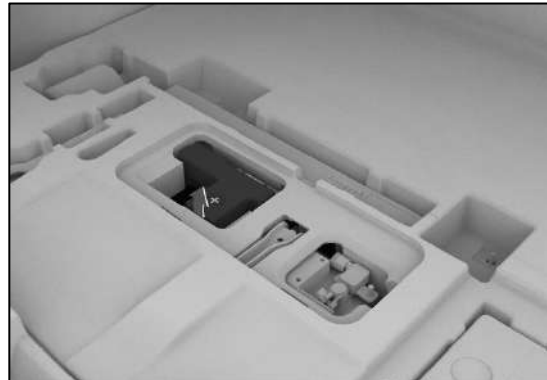

98FE020C1FOA

3. Connect the booster cables in the following order.

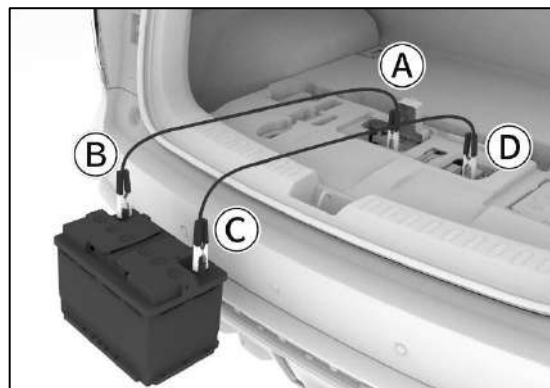

242DEA84CEC9

- (A) Positive terminal on drained battery ⊕
- (B) Positive terminal of battery on rescue vehicle ⊕
- (C) Negative terminal of battery on rescue vehicle ⊖
- (A) Negative terminal on drained battery ⊖

4. Recharge the battery.
Start the recovery vehicle, increase the engine speed slightly, and keep such speed for about 5 minutes to temporarily charge the depleted battery of the vehicle.
5. Start the vehicle with depleted battery.
If still unable to start the vehicle, check that the jumper cables have been connected correctly, and then allow the battery to recharge a little more.
6. Remove the jumper cable.
Once the vehicle is started, remove the jumper cable in an order contrary to the connection.



⚠ WARNING

- › During charging or jump starting, gas may escape from the battery. There is a risk of explosion at this time. Keep the battery away from sparks, open flames and other flammable materials.
- › Battery fluid is corrosive, and it can cause serious injury to eyes and skin. In case of accidental contact, please rinse immediately with plenty of water and seek medical attention immediately.
- › When connecting or removing jumper cables, you cannot wind the cables with fans, belts and the like.
- › Ensure that all cables are connected correctly, and keep a certain distance between their ends to avoid contact between positive and negative poles.

⚠ CAUTION

If a battery is often lack of electricity, please get to authorised service centre for inspections.

Engine overheating

Vehicle equipment

Please note that this manual contains all the standard equipment, country-specific equipment and special equipment for this model series. Thus, some equipment or features described in this manual may not be installed onto your vehicle or are only available in some markets. For further configuration information, please refer to relevant sales information or consult with your distributor selling the vehicle to you.

When the engine is overheated

i NOTICE

Under extreme conditions (such as dragging, towing, climbing, overload, etc.), the engine may overheat and the power of the whole vehicle will decrease.

Overheating symptoms

- › The water temperature is in the red zone.
- › Engine accelerates weakly.
- › There is steam emanating from the hood.
- › A/C compressor may stop working automatically.

Handling methods

1. Park the vehicle in a safe place and shut down the engine.
If the A/C system has been turned on at this point, please turn it off.
2. Check if steam is emanating from the hood.
 - › If no steam is emanated, open the engine hood and then start the engine.
 - › If steam is emanating, wait until there is no more steam. Open up the hood, and then run the engine.
3. Check if the cooling fan is running.
 - › If the fan is not working, shut down the engine and contact authorized service centre.
 - › If the fan is running normally, wait for the water temperature to begin to drop, then turn off the engine.

4. Check the coolant level. Please top up the coolant if the coolant level is too low. And check for pipeline leakage; if there is any leakage, please contact authorised service centre.
5. Check whether there is any foreign object in the core of the radiator. If there is any foreign object, remove it.

⚠ WARNING

- › Do not open the engine hood immediately if you see steam emanating from the engine hood. Doing so may cause serious injury such as burns.
- › When the radiator is at a higher temperature, do not open the radiator cap or the overflow tank lid. Otherwise, exiting steam or coolant may cause severe injuries such as burns.
- › When opening the radiator cap or the overflow tank lid, do not touch or get close to the fan and belt. Also, open the cap slowly after covering it with a piece of cloth.
- › When the engine is running, do not touch or get close to the fan and strap. Otherwise, there is a risk of your hands or clothing becoming caught within and of severe injury as a result.
- › Do not refill coolant in an overheated engine. If a coolant is suddenly added, it is easy to damage the engine. Add a coolant after the engine is completely cooled.

⚠ CAUTION

If the water temperature indicator comes to the red warning range again, head to your nearest authorised service centre for inspection as soon as possible.

Towing

Vehicle equipment

Please note that this manual contains all the standard equipment, country-specific equipment and special equipment for this model series. Thus, some equipment or features described in this manual may not be installed onto your vehicle or are only available in some markets. For further configuration information, please refer to relevant sales information or consult with your distributor selling the vehicle to you.

Use a professional vehicle to tow

⚠ WARNING

Traction must comply with local regulations regarding trailer towing.

⚠ CAUTION

In the case of automatic car washing and towing, the parking brake needs to be released. You can directly start the wash/ trailer mode through the multimedia display. (► page 87)

When the vehicle needs to be towed, we suggest an elevating truck or flat truck, and you shall entrust a authorised service centre or a specialized towing company with the traction.

Towing with the flatbed truck

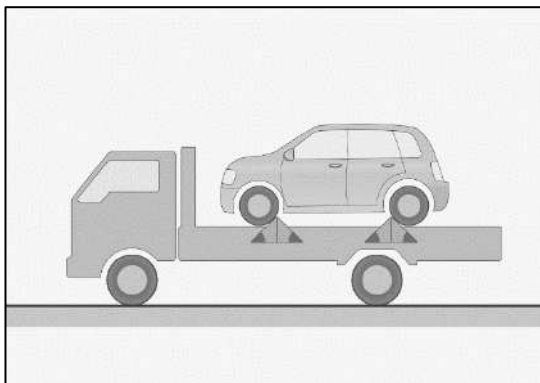

04FD77FA04F8

When using a flatbed truck, you must lock the vehicle firmly.

Towing with the lift truck

Towing from the front

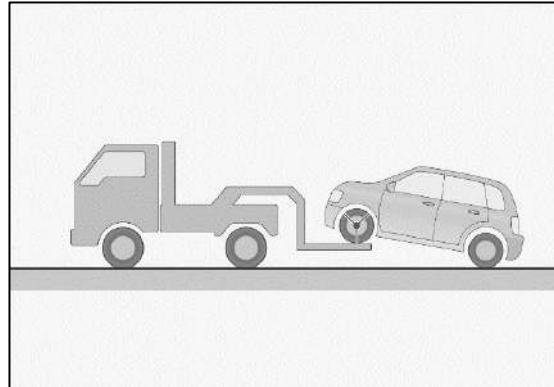

6BB6EC6FBF2F

The rear wheels and axles of the vehicle must be in good condition. The parking brake must be released and the vehicle must be locked securely.

Towing from the rear

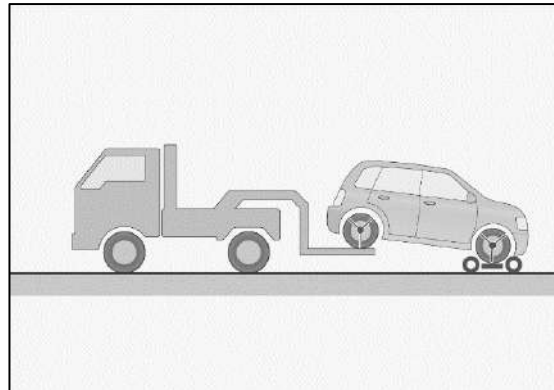

FFEE0CD03B9B

Place the tow truck under the front wheel and lock firmly.

Towing with the hoisting type truck is prohibited

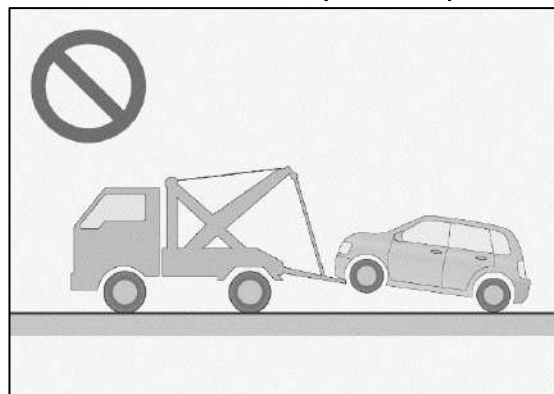

9104EBEC04BC

It is forbidden to use a hoisting type truck for towing, otherwise it may damage the vehicle body.

Towing with the tow hook

Tow hook

Front tow hook

1. In the gap at the tow hook cover, pry down the cover using a flathead screwdriver wrapped by the cloth.

Type I

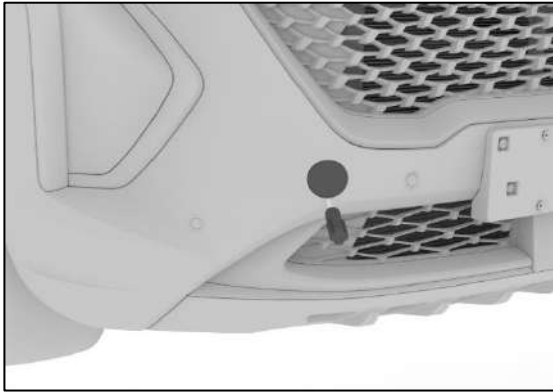

36A59E9ED216

Type II

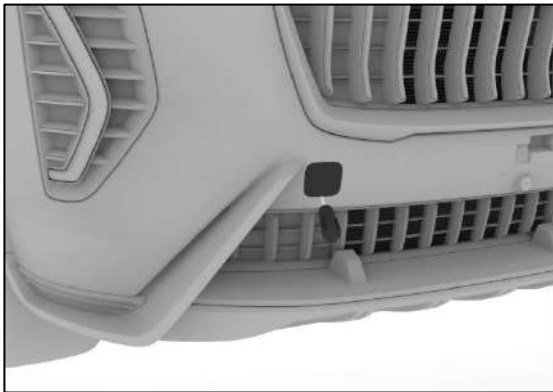

85C6328CEODC

2. Screw the tow hook clockwise into the hole and tighten it to ensure that it is securely installed.

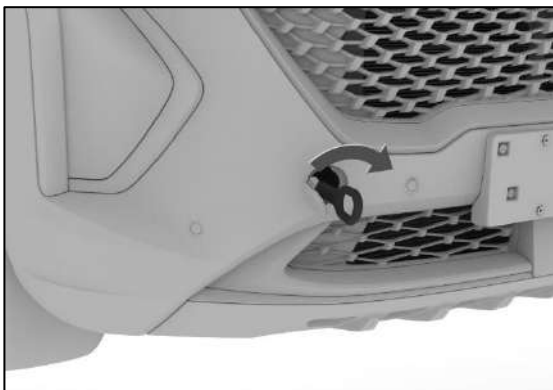

097E12BE67EA

Rear tow hook

1. In the gap at the tow hook cover, pry down the cover using a flathead screwdriver wrapped by the cloth.

Type I

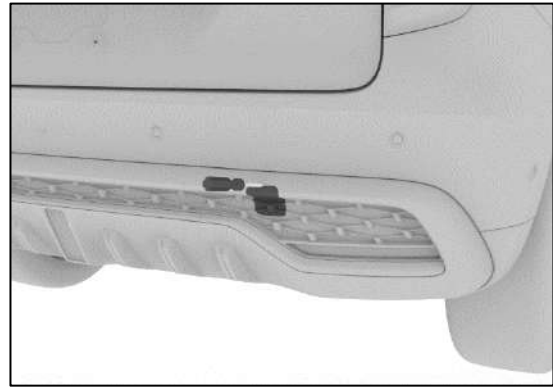

C26365676BAF

Type II



67B9E0D470B2

2. Screw the tow hook clockwise into the hole and tighten it to ensure that it is securely installed.

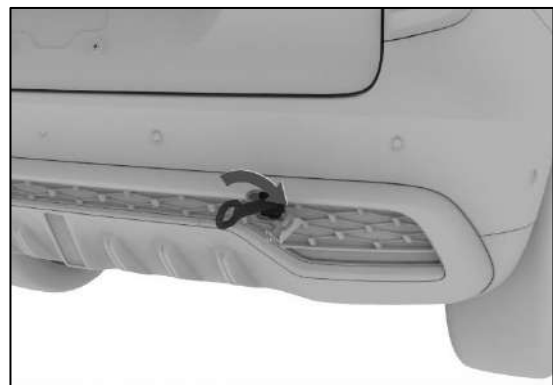

BE4F815B6C12

Tow rope

The tow rope shall be elastic to protect vehicles. It is recommended to use artificial fiber rope or the rope made of similar elastic materials. Tow ropes can only be installed on the designated trailer hook or towing ring of the vehicle.

When installing tow ropes, you shall be careful not to damage the vehicle body. The distance between towing vehicle and towed vehicle shall be more than 4 m and less than 10 m.

A recovery blanket shall be attached to the center of the tow rope. For towing at night, tow ropes with reflective materials shall be used as much as possible to increase the warning effect.

CAUTION

- > Tow rope must be purchased by yourself.
- > Do not use a steel rope to tow as that will damage the bumper.

Vehicle failure occurring

When the vehicle fails, if the towing cannot be performed by special vehicles, a tow hook can be used to tow the vehicle temporarily. This towing method can only be used to tow a vehicle on hard pavement in a short distance at a low speed.

WARNING

Towing must comply with local regulations regarding trailer towing.

Towing the vehicle

For towing the vehicle, the driver must sit in the vehicle and operate the steering wheel and brake pedal, with the wheels, axles, steering system, brake system, transmission system (transmission, etc.) and lighting system (turn signal light and brake light) in good condition.

The detailed methods are as follows:

1. Start the vehicle and shift to the N gear position.

If the vehicle will not start, switch the power supply mode to ON and shift the gear to the N position.

CAUTION

When you cannot switch the transmission to the N gear position, do not use tow hooks for towing.

2. Turn on the hazard warning light, release the parking brake and wait for towing.
The towing speed is not greater than 12 km/h and the towing distance is not greater than 25 km.

CAUTION

- > If the vehicle is not started, the assist system will not work, and the steering and braking operations will be difficult.
The vehicle speed should be reduced as much as possible during towing.
- > During towing, pay attention to the brake lights of the vehicle in front to avoid looseness of the tow rope.
- > When the vehicle moves on a long downhill road, ropes should not be used to tow the vehicle.
- > Do not tow the vehicle backwards.

Towing other faulty vehicles

1. When towing, turn on the hazard warning lights and follow relevant local laws and regulations.
2. Start slowly until the tow rope tightens, then accelerate carefully.

CAUTION

- > Do not tow a vehicle heavier than the towing vehicle; otherwise, the vehicle can be easily damaged.
- > Avoid sudden start or unstable driving operation; otherwise, the tow hook or tow rope will be subjected to excessive tension.
- > When the vehicle moves on a long downhill road, ropes should not be used to tow the vehicle.
- > Do not tow the vehicle backwards.

When the vehicle gets stuck or bottoms out,

When driving in snow, mud and sand, the vehicle is easy to get stuck or bottom out. Therefore, you shall drive carefully.

If the vehicle gets stuck, you can try the following operations:

1. Shut down the engine and apply parking brake.
2. Remove the mud, snow or sand around the stuck tires.
3. Place wood blocks, stones or other materials to help improve the tire adhesion.
4. Start the vehicle again.
5. Release the parking brake and accelerate carefully to get the vehicle out of the pit.

⚠ WARNING

While freeing the vehicle, you should pay attention to the following:

- › Make sure that the surrounding area is clear and free from any other vehicles, objects, or persons.
- › The moment the vehicle gets out from the pit, it will suddenly rush forward or backward, so be careful.

When the vehicle gets stuck or bottoms out, please contact professional rescue teams or service provider if the vehicle cannot get out of the trap in the methods above. Dragging unprofessionally for rescue is prohibited.

⚠ WARNING

Please observe the following precautions during rescue. Otherwise, it will easily cause vehicle damage and even endanger personal safety.

1. When trailer hook is used to tow the vehicle, a recovery blanket must be tied in the middle of the tow rope to prevent the trailer hook or rope from breaking and rebounding, which may cause vehicle damage and even endanger personal safety.
2. It is forbidden to drag the vehicle from the side or vertically, with the best angle of trailer hook within the range of 5° up and down and 25° left and right.
3. It is forbidden to drag the vehicle during race start. The initial towing speed shall not exceed 5 km/h (start slowly until the tow rope is taut).
4. When the vehicle is to be dragged with a trailer hook, the drag/towing force shall not exceed the weight of the vehicle.

Vehicle equipment

Please note that this manual contains all the standard equipment, country-specific equipment and special equipment for this model series. Thus, some equipment or features described in this manual may not be installed onto your vehicle or are only available in some markets. For further configuration information, please refer to relevant sales information or consult with your distributor selling the vehicle to you.

On-board telephone

The button and indicator of the onboard telephone is on the panel of the reading lamp.

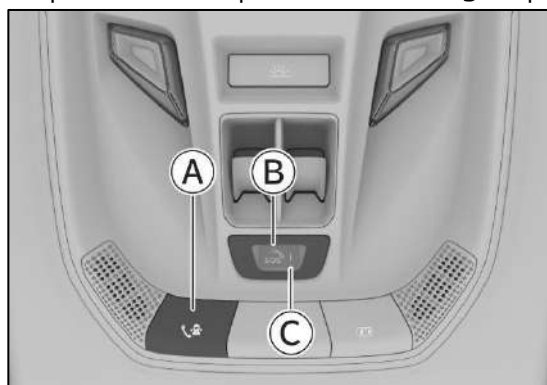

A61A62B80584

- Ⓐ The handle service (☎)
- Ⓑ Emergency rescue button (sos)
- Ⓒ Gateway indicator

Press the cover to open it, then you can operate the emergency rescue button.

⚠ WARNING

When the emergency rescue button does not need to be operated, please close its cover.

i NOTICE

- › The communication device conforms to the standard and requirements of NBTC
- › The electromagnetism field intensity of communication device is consistent with *The Safety Standard for Human Body to Use Radiocommunication Equipment*, published by National Telecommunications Commission (NTC)

Manual services

Press and hold the ☎ manual service button to trigger a manual service call. Through manual services, you can search for destinations and points of interest, inquire about information, book services, consult on car networking problems, request road rescue, etc.

During the manual service call, press and hold the ☎ manual service button to end the call.

Emergency rescue

Press and hold the sos emergency rescue button to trigger an emergency rescue call. During the emergency rescue call, press and hold this button again to end the call.

In the event of a collision (when the airbag is deployed), an emergency rescue call will be triggered automatically, and the call cannot be manually ended.

After an emergency rescue call is triggered, the rescue center will immediately accept the rescue request from the vehicle.

i NOTICE

Do not randomly and frequently trigger the emergency rescue calls.

⚠ CAUTION

The function of emergency rescue call is affected by various factors. Thus, the emergency rescue call may be unavailable in case of any of the following cases (including but not limited to):

- › If the vehicle networking system fails or is damaged, it will be impossible to trigger an emergency rescue call.
- › If the audio equipment is damaged, or the harness connected to the vehicle networking system and the audio equipment is damaged or connected falsely, it will be impossible to make normal rescue calls with the customer service.

- › If the airbag fails to deploy in a minor collision or abnormality, it will be impossible to automatically trigger the rescue call. In this case, you can trigger the emergency rescue call manually or make the call by other means.
- › If the emergency rescue button is damaged, the emergency rescue call cannot be triggered manually.
- › If the mobile network signal (cell phone signal) is weak, interfered, or blocked, etc., it will be impossible to trigger an emergency rescue call.
- › In areas (such as underground parking lots, tunnels, and mountain areas) where the GPS equipment is damaged or the signal is week, it may be impossible to locate the vehicle.
- › After the vehicle is powered off, it may be impossible to trigger an emergency rescue call.
- › The emergency rescue services may not be available due to riots, fires, floods, storms, explosions, wars, government actions, orders given by judicial administrative organs, social environment and other force majeure factors.
- › The emergency rescue services may not be available if other software you have downloaded and installed or other websites you have visited contain viruses,
- › Trojans or other malicious programs and threaten the security of your equipment and data.
- › Situations where other objective factors render the emergency rescue call unusable.

Car networking function indicator

Status of Indicator light	Description
OFF	The car networking system has no network connection (for example, the SIM card used is not registered or cannot be connected to the network).

Status of Indicator light	Description
Orange lamp normally on	Disconnect the battery and re-connect it, indicating that the car networking system is starting.
Orange lamp flashing	During the starting of the car networking system, it is in a call state.
Green Lamp normally on	The car networking system works normally and has normal network connection.
Green light flash	The car networking system is in a call state.
Red lamp Normally on	The car networking system fails to pass the self-inspection and is in an error state.

WARNING

It is forbidden to modify the car networking system.

NOTICE

Please observe the following suggestions during daily use:

- › Regularly check whether the car networking system is running normally.
The indicator of the car networking system is green, indicating that the system is normal. If there is a fault, please go to the service station for inspection and maintenance in time.
- › It is recommended to replace the builtin battery of the car networking equipment once every 3 years at most.
Please go to the service station to replace the battery in time.

6

Maintenance

Necessity of vehicle maintenance.....	190
Engine compartment.....	191
Engine compartment.....	197
Vehicle maintenance.....	201
Regular maintenance table.....	207

Necessity of vehicle maintenance

Vehicle maintenance, a health diagnosis of the vehicle, can reduce the trouble of repairing the vehicle.

When the vehicle is in use, its components and parts will inevitably wear out. To ensure safe driving conditions, regular inspections, maintenance, and repairs are required to maintain and restore vehicle performance.

Vehicle maintenance making you drive more safely

During the maintenance, you can carry out necessary preventive maintenance according to the use of the components and parts, so that you can safely drive the vehicle before the next maintenance.

Extending the service life of the vehicle and reducing the use cost of the vehicle

Components and parts such as brake linings and tyres, etc. cannot be used permanently, as they will gradually wear out while in use. Use of components and parts that exceed the wear limit is likely to cause vehicle breakdown and even lead to traffic accidents. Therefore, it is necessary to conduct regular maintenance.

Engine compartment

Vehicle equipment

Please note that this manual contains all the standard equipment, country-specific equipment and special equipment for this model series. Thus, some equipment or features described in this manual may not be installed onto your vehicle or are only available in some markets. For further configuration information, please refer to relevant sales information or consult with your distributor selling the vehicle to you

Tips for safety

WARNING

- › The engine compartment is a hazardous area of operation and must be handled with extreme caution!
- › When performing fluid inspection and filling operations, observe the following requirements, otherwise burns or fire may occur:
 - Switch the power mode to OFF mode.
 - Apply parking brake.
 - Let the motor and drive motor cool completely.
 - Keep children away from the engine compartment.
 - Do not splash fluid on a hot engine.
 - Do not allow water to come into contact with the engine compartment.
- › When performing operations related to fuel system or electrical devices, observe the following precautions, otherwise fire may occur:
 - Disconnect the negative terminal of the battery.
 - Do not smoke.
 - Do not operate near open flames.

CAUTION

When adding fluid, be careful not to misuse it. Otherwise, it may cause serious functional defects or damage to vehicle components.

Fluid level

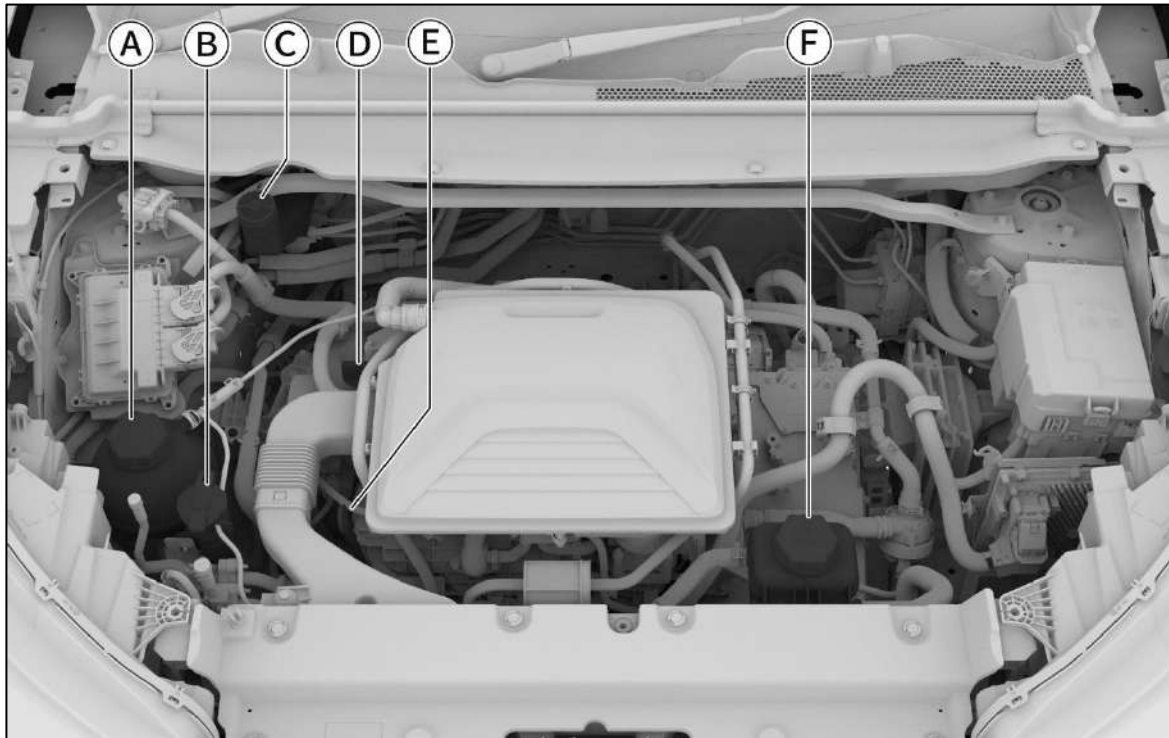

B4AEB0959B99

- (A) Engine coolant overflow tank
- (B) Windshield washer fluid reservoir
- (C) Brake fluid reservoir
- (D) Engine oil filler cap
- (E) Engine oil dipstick
- (F) Overflow tank of drive motor coolant

Engine oil

Check

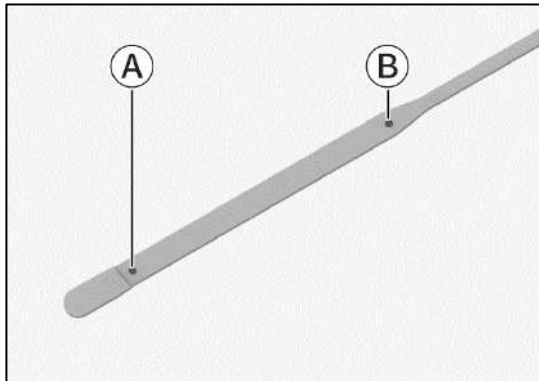

8F3D41CDBC64

(A) Minimum

(B) Maximum

Stop the vehicle on flat ground and warm up the engine to normal water temperature. Then, switch the power mode to OFF mode, and pull out the engine oil dipstick and clean it out after 10 minutes. After that, fully insert the oil dipstick to the oil dipstick conduit; finally pull out the oil dipstick and check the oil level after 10 s.

The oil level should be between the maximum and minimum levels marked on the oil dipstick. If the engine oil level is close to or lower than the minimum level marked, top up engine oil until it is at the level between the maximum and minimum levels marked.

i NOTICE

The actual size and shape of the oil dipstick vary from engine model.

⚠ WARNING

- > When the engine is running, if you close contact with rotating parts such as the strap or fan, your hands, clothing, tools and so on, may be trapped into the rotating parts, resulting in severe consequences.
- > Care should be taken to prevent burns when checking or filling engine oil.

- > Care should be taken to prevent burns when checking or filling engine oil. Keep the engine oil in a safe place when it is not in use. If the engine oil leaks into the ground or floats on the water surface, environment will be polluted.

Filling

Open the engine oil filler cap, and slow pour the oil so as to avoid oil spill. Any oil overflow must be removed immediately. Otherwise, the spilled oil may cause damage to the compartment components.

Engine oil plays an important role in ensuring engine performance and longevity. Therefore, it is important to use high quality, purified oil. Please use only engine oil that meets specifications so as to ensure the vehicle performance.

Oil additives

Your vehicle does not require any oil additives, as additives cannot improve the performance and durability of the engine but product chemical reacts with engine oil causing oil invalid and damaging engine.

⚠ CAUTION

- > Therefore, check and replace engine oil on a regular basis. Otherwise, insufficient oil levels or deteriorated engine oil may cause poor lubrication of engine rotation parts, thereby cause sintering and hence damage to the engine.
- > The engine oil works to lubricate and cool. Oil levels go down over time even if you are driving normally, as a certain amount of engine oil in the lubricant piston and valve also ends up being spent in combustion chamber. Engine oil levels may go down depending on your specific drive conditions.
- > Take care not to exceed marked maximum levels when topping up engine oil.

Brake fluid

Check

The fluid level in the tank should be checked regularly.

Check that the fluid level in the tank is between the minimum and maximum marked levels.

If the brake fluid level is lower than the minimum level marked, top up with new brake fluid until the level is between the maximum and minimum levels marked.

Also make sure that the braking system shows no signs of leakage.

Filling

Pry open the tank cover. Pour in the fluid slowly to prevent overflow. Any oil overflow must be removed immediately.

Otherwise, the spilled oil may cause damage to the compartment components.

Please only use brake fluid that meets specifications.

WARNING

- › Insufficient brake fluid levels can compromise brake performance and increase the risk of an accident.
- › Brake fluid is harmful to the human body and corrosive. In case of accidental contact, rinse immediately with plenty of water. If you ingest it, go to a hospital immediately.

Engine/drive motor coolant

Checks

The water level in the overflow tank should be checked regularly.

Check that the fluid level in the overflow tank is between the minimum and maximum marked levels.

If the coolant level is lower than the minimum level marked, top up with new coolant until the coolant level is between the maximum and minimum levels marked. Also make sure that the cooling system shows no signs of leakage.

Filling

When the engine and drive motor cools, slowly open the lid to let the pressure out.

If the coolant spills, clean it up immediately to prevent parts or paint from being damaged.

Be sure to use the specified type of coolant.

CAUTION

- › The coolant contains ethylene glycol to lower its freezing point. Indiscriminate disposal may lead to water pollution.
- › Do not open the overflow tank cover when the engine compartment is at a high temperature. There may still be some pressure inside the cooling system. Opening it at this point may cause burns or other injuries when heated coolant spurts out.
- › When replacing the engine coolant or when the drive motor battery is very short of coolant, contact authorized service centre.

Windscreen washer fluid

Filling

Open the tank cover. Pour in washer fluid slowly to prevent overflow. Any washer fluid overflow must be removed immediately.

You should use quality washer fluid for better cleaning capabilities and for antifreeze protection in cold season.

NOTICE

You should use the detergent with enough anti-freeze performance, if the ambient temperature is lower than 0 °C.

The detergent should be placed out of the reach of children to avoid accidental ingestion.

The detergent is flammable and should be stored far from fire.

CAUTION

Please do not top up liquids such as soapy water into the tank in place of the detergent. Otherwise, the paint on vehicle body may be damaged.

⚠ WARNING

Do not top up washing fluid when the engine is at a high temperature, or when the engine is running.

This is because the washing fluid contains alcohol. Spilling the fluid on the engine carries a risk of fire.

Radiator and fan

Regularly check the radiator, fan and other heat-radiating components in the engine compartment. If a component is particularly dirty or has foreign objects, please clean it in time. When you cannot determine whether it is working normally, please send your vehicle to a authorized service centre for checking.

Please timely check whether the radiator, fan and other heat-radiating components are covered with dirt when the vehicle is driving in a bad environment (such as driving through water, sand and mud) each time. If they are covered by dirt, please go to a authorised service centre for inspection and cleaning timely.

Safety labels and identifiers

Engine compartment warning label



6FC9C3B803CD

This label is located on the engine compartment front cover plate or the front grille trim plate to prompt you:

- › The type and filling amount of air conditioning refrigerant.

- › The cooling fan may be started at any time. Do not put your hand into the fan shield. Otherwise, when the fan is started unexpectedly, serious personal injury may be caused.

Engine coolant warning label

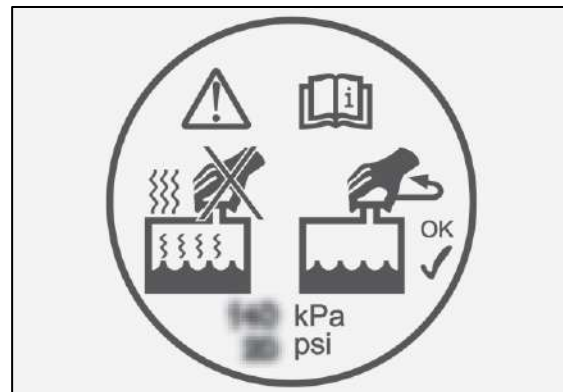

7292828C8D61

The identifier is located on the overflow tank of the engine coolant. It serves to remind you to refrain from opening the overflow tank cover when the engine and the radiator are overheated. Otherwise, the hot liquid and steam be forced out under system pressure, causing burns.

Warning label of drive motor coolant



265F2549F1C8

The label is located on the overflow tank of the drive motor coolant. It serves to remind you to refrain from opening the overflow tank cover when the drive motor is overheated. Otherwise, the hot liquid and steam may be forced out under system pressure, causing burns.

Battery warning label

Type I



340CF5EC9B21

Type II



A86516835B47

This label is located on the battery to inform you of the following precautions before installing, removing, or inspecting the battery:

- › Children should be kept away from the battery.
- › The battery may produce flammable gases in the use or charging process, so it should be away from high-temperature heat source and open flame.
Otherwise a fire or explosion is likely to occur.
- › The battery contains corrosive liquid.
- › Take necessary protective measures such as wearing goggles during operation.

Parts replacement

Vehicle equipment

Please note that this manual contains all the standard equipment, country-specific equipment and special equipment for this model series. Thus, some equipment or features described in this manual may not be installed onto your vehicle or are only available in some markets. For further configuration information, please refer to relevant sales information or consult with your distributor selling the vehicle to you.

Fuse

If any electrical components do not work, the fuse may have been blown out. In this case, carry out the inspections based on the following operations and replace the fuses if necessary:

1. Turn off all electrical components.
2. Switch the power supply to OFF mode, apply the parking brake, and disconnect the negative terminal of the battery.
3. The fuses are located in the following positions:

> Located in the fuse box of the engine compartment



OE039B6DC904

Press and hold the two pawls on the fuse box cover, and then pull up the fuse box cover to open the fuse box.

> Located in the instrument panel near the steering wheel



3C95CEB1BB63

Remove the cover and you can see it.

> under the luggage area cover plate



A90DD219A480

Take out the luggage area cover plate, on-board toolkit and tray on the left in sequence. Press and hold the pawls at the fuse box cover as shown, and then remove the fuse box cover and you can see the fuse.

⚠ CAUTION

- > Never let water or other liquids get into the fuse box. Otherwise, the electrical components will be damaged.
- > Install the fuse box cover on the fuse box correctly. Otherwise, penetration of moisture or dirt will affect the use of fuses.

- Use the fuse clips in the vehicle to pull out the fuses. Locate the fuse of the faulty electrical appliance according to the fuse label and check it

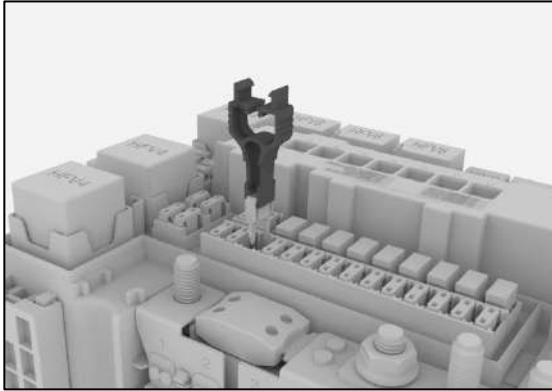

45B3BB806093

⚠ CAUTION

- › The fuse clip and the spare fuse are located in the cover of the engine compartment fuse box.
- › The engine compartment fuse box cover and the instrument panel fuse box cover plate are attached with fuse labels. With these labels, the relationship between fuses and electrical components can be determined.
- › Since there may be more than one fuse causing the failure, check all the fuses that may cause the failure before the failure disappears. If the failure cannot be eliminated in the end, contact a authorised service centre for handling.

- Check the wire inside the fuse. If it is blown out, replace it with a spare fuse of the same amperage.

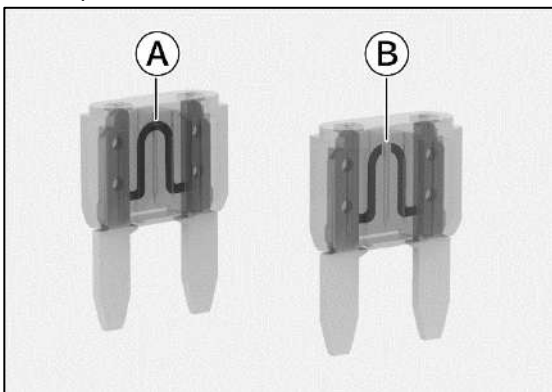

6DC672024A26

- (A) Normal fuse
- (B) Blown fuse

⚠ WARNING

For blowout fuses, do not try to repair or replace them with fuses with inconsistent colours or amperages; otherwise, a fire will occur due to cable overload.

- Check whether the electrical components return to normal operation.

⚠ CAUTION

If a spare fuse with the same amperage is blown out again in a short time or the electrical components do not return to normal operation, the vehicle may have a serious electrical system failure. In this case, contact a authorised service centre for assistance timely.

Wiper blade

Front wiper blades replacement

Regularly check the wiper blade, and replace it immediately if you find the following conditions:

- › Cracks or hardened areas are found on wiper blades.
- › Streaks or dirt are left after using the wiper.

⚠ CAUTION

When lifting and putting back the wiper, you should not pull the wiper blade directly to avoid deformation or even damage.

- Switch the power supply to the OFF mode, and pull up the wiper control combination switch in the direction vertical to the steering wheel and hold for about 3 seconds. Then the wiper will automatically reach the service position, as shown in the figure.

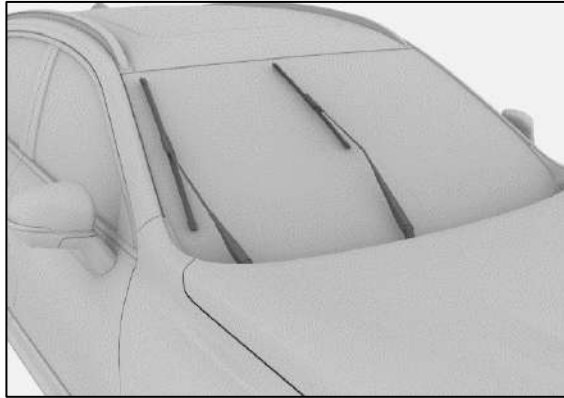

995F8C7650B5

- Lift the wiper arm from the windscreen.

⚠ CAUTION

- › To lift the wiper, be sure to bring the wiper to the maintenance position. Otherwise, the wiper will be damaged.
- › Do not open the engine hood while the wiper is lifted. Otherwise, the engine hood and the wiper will be damaged.

- Rotate the wiper blade in the direction indicated to maximize the angle between it and the plastic connector.

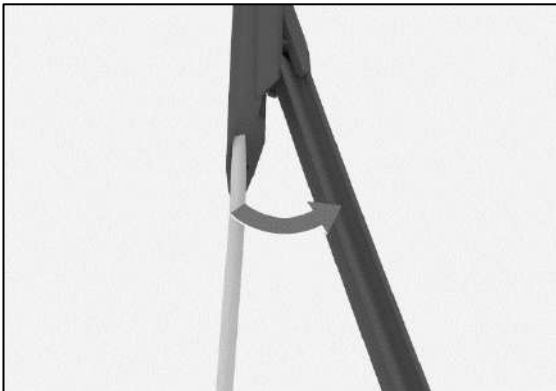

B26AF2BA18B2

- Remove the wiper blade from the wiper arm.

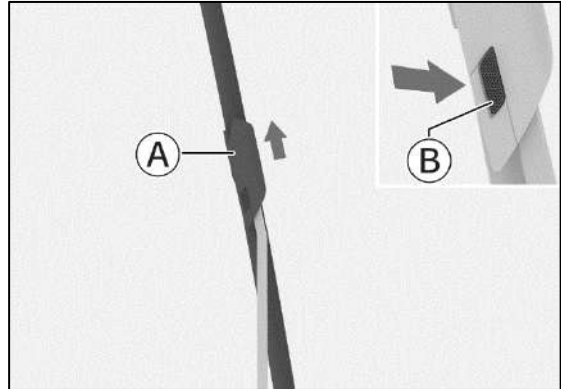

70E1DDF744AB

- (A) Wiper blade
(B) Flexible cleat

Press down the flexible cleat and pull the wiper blade in the direction indicated at the same time until it separates from the wiper arm.

⚠ CAUTION

When the wiper blade is not installed, never place the wiper arm directly on the windscreen as this will damage the windscreen.

- Install a new wiper blade and return the wiper back to the windscreen. For easy installation, please refer to step 3 to maximize the included angle between the wiper blade and the plastic connector. After installation, move the wiper up and down to ensure that it is installed in place.
- Reset the wiper to the initial state. The wiper automatically resets to the initial state when the power supply is switched to the ON mode or the engine is started.

Replace rear wiper blade

- Lift the wiper arm from the windshield.

⚠ CAUTION

The rear wiper arm has a limited lift angle of about 45°. Do not over lift or use excessive force when lifting up, otherwise there is a risk of damage.

2. Pull the wiper blade in the direction shown until the blade is free of the wiper arm.

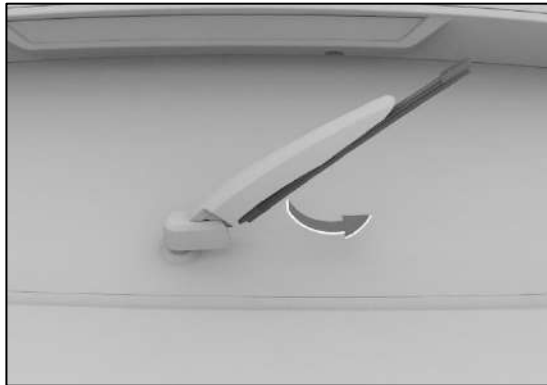

D62652B4F7A6

⚠ CAUTION

When the wiper blade is not installed, never place the wiper arm directly on the windshield as it is capable of scratching the windshield.

3. Install a new wiper blade and return the wiper back to the windshield.

Bulbs

The front combination lamps on a new vehicle have been calibrated at the factory. If you often carry heavy items in the vehicle, the front combination lamps may need to be re-calibrated. The calibration of the front combination lamps should be done at authorised service centre.

Bulb inspection

You should regularly check the condition of the exterior lights. Burnt-out bulbs will lower visibility and also the vehicle's ability to signal to other drivers in the dark. This means that vehicle safety will be severely compromised under such circumstances.

Replacing bulbs

Bulbs should be replaced by a professional.

Normally, you should not replace damaged bulbs yourself, and should allow a professional to perform this job. The primary reason is: before replacing the bulbs you must remove other parts from the vehicle, especially so for those bulbs that can only be removed from inside the engine compartment. Due to this, we recommended that you visit authorized service centre to replace the bulbs.

⚠ WARNING

- › The inside of the bulbs is pressurized, and there is a danger of injury as they may burst during replacement!
- › If the vehicle is equipped with a xenon lamp, do not turn on the headlamp when replacing the xenon bulb. Otherwise, high voltage may cause serious bodily injury.
- › Modification of external lighting and signaling devices is prohibited.
- › It is forbidden to add external lighting and signaling components beyond what is in the compulsory standard specifications.

About lamps fogged

Under conditions such as driving or washing vehicle on a rainy day, there may be fog inside the lamp cover. This is caused by the temperature difference between the inner and outer air of the lamps and it is the same phenomenon with the window glass fogging on rainy days. It doesn't mean any problems in function. However, when a significant amount of water or water vapor accumulates inside the lamp glass cover, please contact your authorised service centre for assistance.

⚠ CAUTION

Do not use chemical solvents or strong cleaning agents to scrub the external lamp cover to avoid damage to it.

Vehicle equipment

Please note that this manual contains all the standard equipment, country-specific equipment and special equipment for this model series. Thus, some equipment or features described in this manual may not be installed onto your vehicle or are only available in some markets. For further configuration information, please refer to relevant sales information or consult with your distributor selling the vehicle to you.

Tyre maintenance

To ensure a safe drive, make sure that the tyres used suit your vehicle and that they possess a good tread and appropriate tyre pressure.

⚠ WARNING

- › Do not use the excessive wear tyres or tyres with insufficient tyre pressure; doing so may lead to an accident, injury.
- › You must abide by all manual instructions regarding tyre inflation and maintenance.
- › Burning tyres by individuals produces toxic gases. Please head to a authorised service centre for service.

Tyre check

When checking tyre inflation state, you should also check that there is no external damage, embedded foreign objects or excessive wear, etc. If any of the following circumstances are found, you should replace the tyre as soon as possible:

- › There is damage and bulging in the tyre surface or side.
- › There is excessive wear to the tyre tread.

Tyre pressure

Maintaining appropriate tyre pressure levels can maximize vehicle handle ability, tyre tread life and drive comfort.

Uneven wear of under-inflated tyres also impacts the handling of the vehicle and fuel consumption, and may cause tyres to go flat due to overheating.

Over-inflated tyres can lead to an uncomfortable ride as well as damage to the tyre due to uneven road surfaces, as well as uneven wear to the tyres.

It is recommended that you check the tyre pressure regularly.

Tyre pressure should be measured when the tyre is cold. If the vehicle is parked for more than 3 hours or driving distance is not more than 1.5 km, the measurement will get more accurate data.

When checking tyre pressure after the tyre has been warmed up (after a drive), the pressure reading will be 30 to 40 kPa higher than the cold-state reading.

This is normal. Do not deflate the tyre to achieve recommended cold-state pressure levels at this point as this will lead to insufficient tyre pressure levels.

i NOTICE

The tyre pressure in normal tyres can go down by 10 to 20 kPa every month.

Please check regularly.

Tyre wear

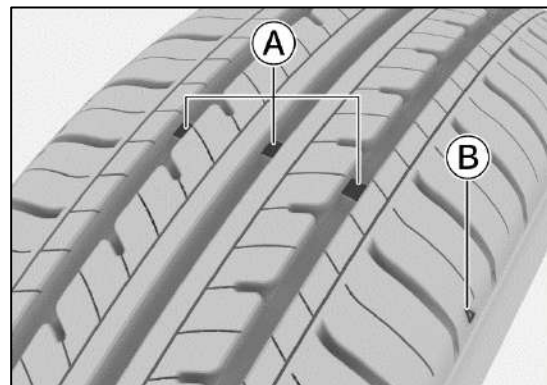

FF3563DBE361

(A) Tyre wear mark

(B) Tyre wear mark position figure

i NOTICE

Tyre wear mark position figure is a schematic diagram, which is used for reference only.

Please refer to the actual vehicle.

You must replace tyres as soon as possible once they are worn down to the maximum tolerable limit.

If you continue to use tyres with shallow treads or where the tyre wear mark has appeared, it will lead to situations such as longer braking distances, difficulties in steering and cracked tyres and possibly accidents as a result.

If you find the tyres are worn unevenly, or feel a certain continuous vibration when driving, go to a authorised service centre.

When installing new tyres, tyre balancing must be performed to ensure ride comfort and to prolong tyre use life.

Tyre rotation

In order to extend the life of the tyre and make tyre wear even, it is recommended that the tyres of the rear and front wheels be exchanged on a regular basis.

The tyre rotation should be done by the professionals and it is recommended to be done by a authorised service centre.

Wheel balance

Unbalanced wheels can affect vehicle manipulation performance and tyre life.

Even under the normal use conditions, the wheels may lose their balance.

Therefore, the wheels should be balanced according to the wheel balancing parameters.

Avoid tyre flat spot

If the vehicle is parked in a high temperature environment for an extended period of time, a slight deformation of the tyre in the contact position with the ground may occur, which is called "flat spot" and is normal. However, when the vehicle is running, the vehicle body and steering wheel may shake. As the mileage increases, the tyre will get hot and return to its original shape, and the shake will gradually disappear.

When the vehicle is stationary for an extended period of time, the tyre flatness can be minimized by any of the following methods:

- › The tyre pressure can be increased (about 300 kPa), which cannot be used for normal driving. Before driving, the tyre pressure must be restored to the recommended tyre pressure.
- › Vehicles must be moved at least once every 30 days (15 days best) and the movement must be rotated at least 90°.

Sunroof maintenance

Daily maintenance frequency

The daily maintenance frequency depends on the driving condition and the use frequency of the sunroof.

If you are driving through sandy areas or areas with high rainfall levels, it is recommended that you increase the frequency of routine maintenance.

⚠ CAUTION

If the sunroof is not maintained on schedule, it can lead to sunroof leaks or abnormal noise. Adjust maintenance frequency depending on the conditions of use. For instance, in sandy zones or in seasons when there is higher usage, you should increase the frequency of routine maintenance.

Routine maintenance procedure

Dust and impurities may be concentrated in the sunroof seal strip, mechanical parts or rails, which may result in an abnormal sound or malfunction of the sunroof and also clog the drainage system.

Regularly open the sunroof, remove dust and impurities, and use clean cloth and water to wipe the sunroof seal strip surface, as well as regularly apply grease on the mechanical parts for maintenance.

Open up the sunroof and check that the sunroof does not show signs of being obstructed in the course of operation. If there seems to be obstruction, please head to a authorised service centre for services.

⚠ CAUTION

- › **When the sunroof malfunctions, please head to a authorised service centre as soon as possible for check and maintenance.**
- › **In cold icing conditions, do not try to forcibly open the sunroof to prevent damage to the sunroof motor and sunroof seals. You must wait for the interior temperature to rise and for seal strips of sunroof and sunroof opening to defrost before you try to open the sunroof.**
- › **Open the sunroof after washing the vehicle in cold icing conditions. Use a piece of soft, dry cloth to wipe dry seal strips of sunroof before driving.**
- › **The sunroof must be closed fully before the vehicle enters a car wash facility.**
- › **Do not allow water jets to be pointed directly at seal strips of sunroof.**
- › **Keep off the water from vehicle due to the deformation of the seal strip under the pressure of the high pressure water column, as a result, it may damage the seal strip.**
- › **When driving on bumpy roads or in hilly areas, do not open the sunroof fully for extended periods of time as the vibrations may cause damage to internal sunroof components.**
- › **In the rainy season, step up checks for any sand or dust on seal strips of sunroof, and remove them in a timely manner to ensure good sealing performance of sunroof.**

Battery

The vehicle is equipped with a maintenance-free battery.

The battery is located under the luggage area cover plate.

When the battery shows low level, it is necessary to charge or replace the battery in time. Head to a authorised service centre for service if you need to replace the battery.

Exterior maintenance

Wash vehicle

A regular vehicle wash helps to protect its appearance. Dust and sand grains can damage the paint surface while fallen leaves and bird droppings can take the shine off the paint surface.

Clean methods

1. Check that there are no fallen leaves, bird droppings, etc., on the vehicle body.
Clean these dirt with a rag or a scavenger, then rinse immediately with clean water so as not to damage the vehicle body surface finish.
2. Wash the vehicle thoroughly with water to remove surface dust.
Clean your vehicle using the solution and a soft brush, sponge, or a piece of soft cloth.
3. Fill a bucket with water. Add automobile detergent to prepare a solution.
Start your cleaning from the roof and work downwards.
4. After washing and cleaning the entire vehicle, use a dedicated wipe cloth or towel to dry off the vehicle. Do not allow the vehicle to dry out naturally as this may cause the vehicle body to lose its luster or generate water stains.

⚠ CAUTION

- › **Chemical solvent and strong cleaning solution can cause damage to the vehicle body paint as well as metal and plastic components of the vehicle.**
- › **After washing the vehicle or driving through flooded road, step on the brake pedal lightly to make sure that the brake is functioning normally.**

- › When washing the vehicle in cold season, do not flush the gaps in the keyholes or doors, etc. to prevent the lock hole or seal strip from freezing.
- › When cleaning the vehicle, it is forbidden to open the fuel tank door to wash its interior.

Waxing

Waxing is conducive to vehicle maintenance, and the vehicle must be thoroughly cleaned before waxing in order to ensure the effect of waxing.

At present, there is a wide range of car wax in the market, and the car wax performance is different, so you must be careful when selecting the wax. Otherwise, the wax will result in paint discoloration instead of protecting the vehicle body.

Under normal circumstances, the role and characteristics of car wax, the degree of vehicle age, paint color and driving environment and other factors should be taken into account. For details, please contact a authorised service centre or professionals.

Repairing paint surfaces

Always check to see whether there are any paint dropped off or scratches on the vehicle body surface. If such a phenomenon occurs, it should be repaired immediately to prevent corrosion of the metal in the damaged area.

Repair paint can only be used to repair small areas of dropped-off paint or scratches, large areas of dropped-off paint should be repaired by professionals.

Liquid leakage check

Park your vehicle on a flat surface and leave it for a while to check for leaks of fuel, oil or other liquids. In case of the apparent leakage, please contact a authorised service centre for service.

Interior maintenance

⚠ WARNING

Cleaners may contain harmful substances and the people may subject to a danger of injury if affected. When cleaning the internal vehicle, it is recommended to open the vehicle door or vehicle window. Only the cleaner specified for vehicle cleaning shall be used and the instructions on the package shall be noted.

i NOTICE

- › Do not allow water or any liquid come into contact with instrument panel, floor or electrical components when cleaning the interior as water will damage those components' function.
- › Please do not clean the vehicle floor with water in order to avoid vehicle body corrosion.

Carpet

The dust on the carpet should often be cleaned by a vacuum cleaner. Too much dust will accelerate the damage of the carpet.

Wash the carpet regularly with detergent, which can keep the carpet clean. Foam carpet cleaner should be used. To keep carpeting as dry as possible, do not add water to the foaming cleaning solution.

Textile fabrics

The dust and dirt on the textile fabrics would often be cleaned by a vacuum cleaner.

For general cleaning, use a clean soft cloth soaked with mild and neutral soapy water. To avoid watermarking after drying, wipe it with another clean, soft damp cloth and then dry in the air. To remove stubborn stains, use a textile fabric cleaner. Please follow the detergent instructions to operate.

Leather

Dust and dirt should be cleaned regularly by a vacuum cleaner, especially creases and seams. Clean the leather with a soft cloth soaked with water and then polish it with another soft dry cloth. If you require further cleaning, you may use a special leather cleaner.

After wiping with a leather cleaner, follow up with a piece of soft and dry cloth to clean off any residue as quickly as possible. Never allow a leather cleaner be placed on any inside surface for an extended time. Certain leather cleaners can cause the resin or fibers in inside textiles to fade or break up.

Rubber parts

Affected by the environment, the rubber parts may be covered with stains and tarnished on the surface. Thus, the rubber parts should be cleaned regularly by the rubber curing agent, especially the worn rubber parts.

In order to avoid damage or noise, please make sure not to use silicon contained curing agent in the daily maintenance of rubber seals. Only water and suitable curing agent should be used to clean.

Plastic parts

i NOTICE

Liquids containing alcohol or solvent (such as nitro diluent, cooling cleaner, fuel, perfume and cosmetics) may damage the surface of parts. Use microfiber soft cloth (slightly wet with water) to clean.

Plastic components include but are not limited to the following: artificial leather surface, roof lining, vehicle lamp glass roller shutter, vent assembly and inside paint parts.

Vehicle window

Clean the inside and outside of the window with a glass detergent and wipe all the glass and plastic surfaces with a soft cloth or paper towel.

⚠ CAUTION

If a heating wire is attached to the inside of the rear vehicle window, excessive forceful wiping may cause it to shift or break. Therefore, lightly wipe it along the direction of the heating wire.

Seat belt

- › If a seat belt becomes dirty, please use neutral warm soapy water to scrub it. Do not use bleach, dyes or cleaning solvents that can reduce the durability of the seat belt. Before driving, you should allow the seat belt to dry naturally in the air.
- › Too much dust on the seat belt guide ring can lead to slow contraction of the seat belt; neutral temperature soapy water can be used to scrub the inner side of the guide ring.

Anti-corrosion measures

Factors that affect the corrosion rate

- › The accumulation of dirt, dust, or snow in the lower part of the vehicle body can accelerate corrosion.
- › Damage to the coating or other protective layer, arising from sand attacking or minor accident, may quicken corrosion.
- › If the vehicle runs in areas where relative humidity is high or temperature is above freezing point, it may quicken corrosion.
- › There is much salt in the air and on the road of industrial pollution areas and coastal regions, which may quicken the paint corrosion.
- › Rising temperature may quicken the corrosion of poorly ventilated parts.

Protect the vehicle from corrosion

- › Regularly use clean cold water and neutral vehicle detergent to wash the vehicle so as to keep it clean.
- › Regularly check whether the paint is damaged. If it is, repair it as soon as possible.
- › Regularly check the lower part of the vehicle body. If there is sand, dirt, snow, ice or other coverings, clean them with water as soon as possible.
- › Keep the door drain hole open so as to avoid water logging.
- › If insects, asphalt, cement or other similar objects are accumulated on the vehicle, clean them as soon as possible.
- › If you always drive on a deicing salt covered road, saline-alkali land, seaside and other roads containing salt, please wash off the attachments at the bottom of the vehicle at least once a month.
- › If you drive regularly on sand road, please consider installing mud flap behind the wheels.

Long-term storage of the vehicle

The parking position of the vehicle should help to prevent deterioration of the vehicle condition and facilitate the restarting of the vehicle. If possible, please park your vehicle indoor. If you need to store the vehicle for an extended period (one month or longer), please take the following steps beforehand:

- › Top up fuel.
- › Clean and dry vehicle exterior thoroughly.
- › Clean the inside of the vehicle to ensure it is clean and tidy.
- › Release the parking brake, and use the wheel chock to hold against the tyres.
- › Open vehicle windows on one side slightly (if the vehicle is to be parked indoors).
- › Disconnect the negative terminal of the battery.

- › Use a stowed towel or piece of cloth to cushion the wiper blade from the windshield glass.
- › To reduce the risk of sticking, silicone lubricant should be applied on all door seals.
- › Use a vehicle cover made of porous cotton to cover the vehicle. Because plastic materials such as non-porous materials will accumulate moisture and is likely to damage the vehicle body paint.
- › The vehicle shall be stored in a ventilated environment, without flammable and explosive materials around.
- › If possible, start the vehicle once every month, and the system will monitor the battery level automatically. If the battery level is low, the engine will run into idle charging mode. When the engine shuts down, charging is finished.
If the battery level is normal, the engine will not start and you can lock the vehicle and leave the vehicle.
- › The power system is behind the luggage area, so do not store flammable, combustible and corrosive objects here.
- › To ensure good startability and dynamic performance, we recommend you that drive at least 2 hours every month.

Regular maintenance table

The first regular maintenance is free of charge, and the cost of regular maintenance incurred thereafter should be borne by the user.

i NOTICE

Please strictly follow the maintenance interval indicated in the table below. If you do not have the vehicle maintained at authorised service centre within the specified period or mileage, you will be deemed to have waived the free maintenance service provided by our company.

Item	Time (month)	6	12	18	24	30	36	42	48	54	60
	Kilometers X 1,000	10	20	30	40	50	60	70	80	90	100
Engine oil*		R	R	R	R	R	R	R	R	R	R
Oil pan plug and washer*		R	R	R	R	R	R	R	R	R	R
Oil filter*		R	R	R	R	R	R	R	R	R	R
Air filter element*		C	R	C	R	C	R	C	R	C	R
Air conditioning filter element (A/C filter)*		C	R	C	R	C	R	C	R	C	R
Engine coolant		I	I	I	I	I	I	I	R	I	I
Brake fluid					R				R		
Spark plug					R				R		
Power battery coolant		I	I	I	I	I	I	I	I	I	I
Automatic transmission oil (DHT oil)							R				
Tyre rotation		I	R	I	R	I	R	I	R	I	R
Canister filter				C			C			C	
Throttle Valve*					C				C		
Disk brake		I	I	I	I	I	I	I	I	I	I
Tyre pressure and wear		I	I	I	I	I	I	I	I	I	I
Ball joint and dust cover		I	I	I	I	I	I	I	I	I	I

Time or mileage, whichever comes first											
Item	שׁמׁרׁתׁ (month)	6	12	18	24	30	36	42	48	54	60
	Kilometers X 1,000	10	20	30	40	50	60	70	80	90	100
Essential bolts and nuts (transmission, braking, suspension, frame and turn signal lamp systems)											
Radiator(appearance)											
Battery 12V											
Panoramic Sunroof	L										
Sunroof - Water drain tube											
Torque of bolt connecting power battery box and chassis											
Power battery case											
High/low voltage connectors of power battery											
SOH of power battery											
Four leaks of the vehicle (oil/ water/electricity/air)											
Vehicle Lights											

CAUTION

- › If the fuel in use contains impurities, replace the spark plug more frequently. If the idle speed of the engine is unstable, you may need to clean or replace the spark plug.
- › Since airbags are safety components and unconventional devices, they do not require routine maintenance. If your vehicle has been in use for more than 10 years since its delivery from the factory, please take it to authorized service centre for inspection or replacement.
- › Some maintenance items may not be applicable to the vehicle you purchased due to different vehicle configurations. Please refer to the actual vehicle models.

NOTICE

Users whose daily driving is less should still regularly go to authorised service centre every 6 months for inspection and maintenance of their vehicles.

7

Technical data

Vehicle identification.....	210
Overall parameters.....	211

Vehicle identification

Vehicle equipment

Please note that this manual contains all the standard equipment, country-specific equipment and special equipment for this model series. Thus, some equipment or features described in this manual may not be installed onto your vehicle or are only available in some markets. For further configuration information, please refer to relevant sales information or consult with your distributor selling the vehicle to you.

Vehicle identification number

The vehicle identification number (VIN) is the identity code of the vehicle and unique to every vehicle. It is engraved in the following locations:

- › The upper left side of the instrument panel.

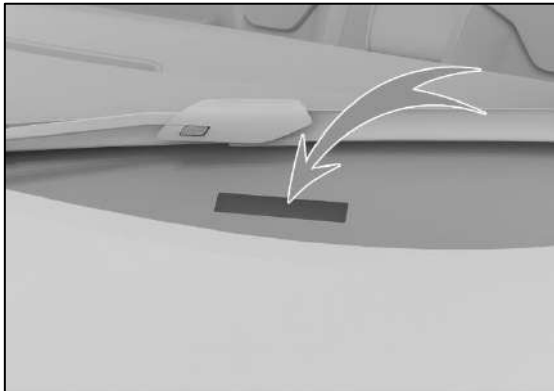

9828120B5453

- › On front mounting beam of the front right seat.



3CF217B15D23

- › On the certification label below the central pillar lock.



5DA9113D7F55

i NOTICE

After using the diagnostic tool to connect the on-board diagnostic interface, you can read the vehicle identification number in the electronic control unit (ECU).

Engine number

GW4G15H

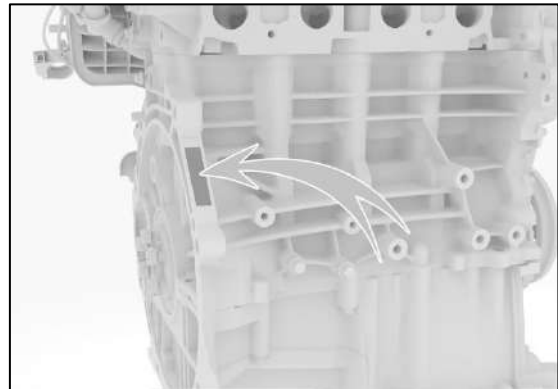

18FFD96A28A1

The engine number is engraved on the engine block, as shown in the figure.

i NOTICE

For easy viewing, a label containing the engine model and number is attached on the lower part of the upper throttle of the engine intake manifold assembly.

Overall parameters

Basic parameters

For basic parameters such as the overall dimensions, quality, fuel consumption, emission standard, maximum speed, see the official vehicle documents attached to the vehicle.

CAUTION

Unless specifically stated or separately listed parameters, all the parameters listed in this manual are applicable to standard vehicles. For specially equipped vehicles and those vehicles produced for other countries, some of the parameters may be different. Parameters in the official vehicle documents attached to the vehicle shall always prevail.

Power parameters

Engine

Model	Type	Maximum net power/speed [kW/rpm]	Maximum net torque/speed [N.m/rpm]	Maximum gradeability [%]
GW4G15H	NA Engine	70/6000	125/4400-5200	30

Drive motor assembly

Model	Type	Rated power/speed [kW/rpm]	Rated torque [N.m]	Peak power [kW]	Peak torque [N.m]
TZ220XS001	Permanent magnet synchronous motor	54/4700	110	115	250

Generator assembly

Model	Rated voltage [V]	Rated power/speed [kW/rpm]
TY220XS001	224	39/7300

Power battery

Model	Type	Rated voltage [V]	Rated capacity [A.h]	Working temperature [°C]
PE339005A	Li-NMC	338.5	5	-35-65
PE338005A	Li-NMC	337.6	5	-35-65
PE336005A	Li-NMC	335.8	5	-35-65

Tyre specifications

Items		Data
Specifications	Standard tyres	215/60 R17 96H 225/55 R18 98V
Tyre pressure		Please refer to the tyre pressure label on the central pillar
Tyre chains	Specifications	TPU polyurethane tyre chain: thickness lower than 6 mm.
	Installation location	Front wheels

Wheel parameters

Items		Data	
Dynamic balance parameters	Unilateral [g]	≤8	
	Bilateral sum [g]	≤15	
Alignment parameters	Rear wheel	Rear wheel camber	-1°30'±30' (right-left deviation ≤30')
		Rear wheel toe-in	0°7'±15' (left and right difference ≤15')
	Front wheels	Kingpin backwards inclination	3°30'±45' (right-left deviation ≤45')
		Front-wheel camber	-0°30'±45' (right-left deviation ≤45')
		Front wheel toe-in	0°6'±5' (Difference of ≤5' between left and right wheel)
Kingpin inwards inclination	11°9'±45' (Reference values)		

Braking parameters

Items		Data
Brake pedal	Free travel [mm]	4~7
Front brake pad (friction material)	Minimum thickness [mm]	2
Rear brake pad (friction material)	Minimum thickness [mm]	2
Front brake disk	Minimum thickness [mm]	20
Rear brake disk	Minimum thickness [mm]	10

Fluid parameters

Engine oil

Specifications of GW4G15H engine oil

If you choose API (American Petroleum Institute) standard oils, we recommend to use fully synthetic oil:

Items	Data	
Ambient temperature	Above -30°C	Lower temperature
Quality grade	SN	SN
Viscosity grade	5W-30	0W-30

If you choose ACEA (European Automobile Manufacturers' Association) standard oils, we recommend to use fully synthetic engine oil:

- › Please use the C2 5W-30 fully synthetic oil when the temperature in your region is above -30°C.
- › Please use the C2 0W-30 fully synthetic oil when your local temperature is less than the above value.

Engine oil capacity

Engine model	Capacity [L] (reference value)	
	When changing both the oil and the oil filter	When only changing the oil
GW4G15H	3.1±0.1	2.8±0.1

Other types of fluids

Fluid type	Specification	Capacity [L] (reference value)
Transmission oil	DHTF2	2.9±0.1
Coolant	Ethylene glycol-based coolant No.-35 (regions other than alpine region) Ethylene glycol based No. 45 (alpine regions)	7.5 ± 0.5 (engine cooling system) 3.5 ± 0.5 (motor cooling system)
Windscreen washer fluid	--	2.5±0.2
Brake fluid	DOT4 synthetic brake fluid	0.72±0.1

i NOTICE

The above oil capacity is the design value, and the actual amount may slightly vary with products, equipment and climate factors.

Seat parameters

Items		Data
Seat slide rail design position		Move 40 mm forward from the last position
Design angle of seat backrest	Front seats	22°
	Rear seats	27°
Common angle of seat backrest	Front seats	20°~27°
	Rear seats	27°

Alphabetical index.....219

Alphabetical index

A

- A/C system 50
- Airbag
 - Front airbags 166
 - Side airbags 168
- Airbags
 - Curtain airbags 168
- Anti-lock brake system 118

B

- Battery 206
- Bottle holder 61
- Brake fluid 197
- Braking force assist system 118
- Break-in period 72

C

- Catalytic converter 120
- Child restraint system 170
 - Fixing point for child seat 171
- Child safety lock 22
- Crankcase emission control unit 158
- Cruise control assist system 120
- Cruise control system 100

D

- Door lock
 - Locking and unlocking with center control buttons 19
 - Locking and unlocking with key buttons 19
 - Locking during emergencies 20
 - Unlocking with the interior handle 20
- Door locks
 - Locking and unlocking through the PEPS 19
 - Locking and unlocking with the mechanical key 20
- Drive motor coolant 197
- Driving mode 84

E

- Electronic braking force distribution system 118
- Electronic parking brake 79

- Electronic Power Steering System 119
- Electronic stability control 119
- Emergency cut-off system 175
- Emergency tyre repair 180
- Engine compartment 197
- Engine coolant 197
- Engine hood 30
- Engine oil 196
- Event data recorder 176
- Exterior maintenance 206

F

- Fatigue driving reminder system 99
- Fluid level 195
- Fluid parameters 216
- Fuses 200

H

- Headrest 31
- Head up display 122
- HHC (Hill-start hold control) 119
- Hill descent control system 117
- Horn 37
- How to jump start the vehicle 183

I

- Indicator light 128
- inflater and tyre repair fluid 180
- Inside rearview mirror
 - Automatic anti-glare inside rearview mirror 35
 - Manual anti-glare inside rearview mirror 35
- Instrument
 - Virtual instrument 123
- Instrument brightness adjustment 43
- Interconnection 146
- Interior maintenance 207

K

- Key 16

Light control combination switch 41

Light height adjustment 43

Reading lamp 43

Side roof lamp 44

O

On-board diagnostic system 121

Outside rearview mirror 35

Oxygen sensor 120

P

Parking assist system

Anti-collision radar 92

Around view monitor 93

Auto parking assist system 94

Parking setting 96

Reverse camera 93

Reverse radar 92

Power supply management system 134

Power parameters 214

Power steering mode 89

Power supply mode 76

Power supply socket 61

R

Radiator and fan 198

Refuelling 29

Rollover prevention system 119

Roof rack 38

S

Seat

Driver's seat memory 33

Front manual seat 32

Front power seat 33

Power battery vent 75

Seat belt 161

Seat parameters 217

Seats

Rear armrest 34

Rear seat adjustment 33

Secondary collision mitigation system 119

Single pedal function 85

Spectacle case 60

Starting and shutting down vehicle 77

Steering wheel 89

Storage case 60

Storage device 60

Sunroof

Opening/closing of sunshade 26

Opening and closing the sunroof 26

Sunroof maintenance 205

Sun visor 59

T

Tailgate

Emergency unlock 22

Manual tailgate 21

Towing 186

Traction control system 118

Tyre inflation 181

Tyre maintenance 204

Tyre pressure monitoring system 152

V

Vanity mirror 59

Vehicle anti-theft system 174

Vehicle identification number 213

Vehicle wash/trailer mode 87

Voice assistant 202

W

Warning light 113

When the engine is overheated 185

Window switch 24

Windscreen washer fluid 197

Wiper control

Automatic wiper 45

Electric front wiper 45

Wireless charging for mobile phones 57



GWM
CONTACT CENTRE
เราพร้อมบริการให้ความช่วยเหลือคุณ
02-668-8888
24hr
ตลอด 24 ชั่วโมง

ยินดีต้อนรับเข้าสู่ครอบครัว **GWM**
หากท่านต้องการคำปรึกษาด้านงานบริการหรือสอบถามข้อมูล
เพิ่มเติม สามารถติดต่อศูนย์บริการข้อมูลลูกค้า
บริษัท เกอท วอลส์ มอเตอร์ เซลส์ (ประเทศไทย) จำกัด

☎ 02-668-8888

1. ช่วยเหลือฉุกเฉิน (Roadside Assistance)
2. ติดต่อเจ้าหน้าที่ลูกค้าสัมพันธ์ (Customer Service)
3. เทเลเมติกส์ (Telematic)

ไม่ว่าแพลตฟอร์มใด
ติดตามเราผ่านช่องทางต่างๆ ได้ที่นี่

	www.gwm.co.th		GWM Application
	GWM Thailand		GWM Thailand
	GWM Thailand		GWM Thailand
	GWM Thailand		